



*Harnessing Energy through Knowledge*

**DESIGN AND CONTROL OF GRID CONNECTED  
SOLAR PHOTOVOLTAIC SYSTEM**

By

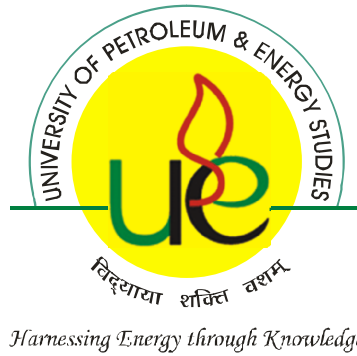
**K N Dinesh Babu**

Submitted

in partial fulfillment of the requirement of the degree of  
Doctor of Philosophy  
to the

University of Petroleum & Energy Studies, Dehradun

May 2014



**DESIGN AND CONTROL OF GRID CONNECTED  
SOLAR PHOTOVOLTAIC SYSTEM**

By

**K N Dinesh Babu**

Submitted

in partial fulfillment of the requirement of the degree of  
Doctor of Philosophy  
to the

University of Petroleum & Energy Studies, Dehradun

May 2014

## **DECLARATION**

I hereby declare that this submission is my own work and that, to the best of my knowledge and belief, it contains no material previously published or written by another person nor material which has been accepted for the award of any other degree or diploma of the university or other institute of higher learning, except where due acknowledgement has been made in the text.

*K.N. Dinesh Babu*

**[K N DINESH BABU]**

Date: 3/April/2014



## UNIVERSITY OF PETROLEUM & ENERGY STUDIES

(ISO 9001 : 2008 & ISO 14001 2004 Certified)

### CERTIFICATE

This is to certify that the thesis on “**Design and Control of Grid Connected Solar Photovoltaic System**” by **K N Dinesh Babu (SAP ID : 500017667)** in partial completion of the requirements for the award of the Degree of Doctor of Philosophy in Engineering is an original work carried out by him under our joint supervision and guidance.

It is certified that the work has not been submitted anywhere else for the award of any other diploma or degree of this in any other University.

#### Internal Guide

A handwritten signature in blue ink, appearing to read 'Kamal Bansal'.

Place: Dehradun, India

[**Dr. KAMAL BANSAL**]

Date: 3/April/2014

[Professor, UPES]

#### External Guide

A handwritten signature in black ink, appearing to read 'V. Balasubramanian'.

Place: Markam, Canada

[**Dr. BALA VINAYAGAM**]

Date: 31/March/2014

[Director - Systems, General Electric]

#### External Co - Guide

A handwritten signature in blue ink, appearing to read 'V. Rajini'.

Place: Chennai, India

[**Dr. V RAJINI**]

Date: 26/March/2014

[Professor, SSN College of Engineering]

**Corporate Office** : Hydrocarbons Education & Research Society  
3rd Floor, PHD House, 4/2 Siri Institutional Area, August Kranti Marg,  
New Delhi 110016 India Ph.: +91.11.41730151-53 Fax : +91.11.41730154

**Campus** : Energy Acres, P.O. Bidholi Via Prem Nagar  
Dehradun 248007 (Uttarakhand) India  
Ph.: +91.135 2776201, 2776061, 2776091 Fax : +91 135.2776090/95

URL : [www.upes.ac.in](http://www.upes.ac.in)

## **DEDICATION**

I dedicate this dissertation to my treasured professors **Dr. V Rajini**, **Dr. R Ramaprabha** and to my beloved **Family**, for their early inspiration, coaching and enthusiasm.

## ACKNOWLEDGMENT

First of all, I render my thanks and glory to the God for the divine providence and guidance all the way through in my life.

I am thankful to the **University of Petroleum & Energy Studies**, Dehradun to admit me as a research scholar for Ph.D. I render thanks to **General Electric** for the support provided by sponsoring the Ph.D. work.

I wish to place on record, my profound gratitude to **Sri Sivasubramaniya Nadar College of Engineering**, Chennai for the support and assistance given to me for utilizing their computational and lab facilities to carry out my work.

I owe my sincere gratitude to my research supervisors **Dr. Kamal Bansal**, Professor, UPES, Dehradun and **Dr. Bala Vinayagam**, Director, General Electric, Canada for their invaluable guidance and suggestions, as well as spending their valuable time in my research work.

I record my deep sense of indebtedness to **Dr. V Rajini**, Professor and **Dr. R Ramaprabha**, Associate professor, SSN college of Engineering, Chennai for providing extraordinary guidance and support throughout my research.

It is my prime duty to acknowledge the inspiration and optimizing encouragement given by my **Parents**, who have been a strong beam of light drawing me from the initial stage of learning. Also, it is my privilege to thank my **wife** and **kids** for the unwavering moral and emotional support throughout my research period.

I express my deepest appreciation to my friend **Mr. Y Mohan Kumar** who has been a pillar of support to me for the detailed analysis of hardware feasibility of this work which can be a future scope of this work.



[K N DINESH BABU]

## **EXECUTIVE SUMMARY**

In recent years micro electric power systems with solar photovoltaic (SPV) generation has increased with deregulation and liberalization of the power market. The increasing power demand and the deficit can be felt by the frequent power cuts in major cities. The depletion of fossil fuels and the stringent policies of Kyoto protocol for suppression of greenhouse gases, forces the world to move towards green energy like hydro, wind and solar. Comparative study of these renewable energies show that hydro and wind are contributing at a very higher rate compared to solar energy. India being a tropical country located near the equator has a very high potential to tap solar power. Study has shown that India receives nearly 3000 hours of sunshine every year, which is equivalent to 5000 trillion kWh of energy which can generate over 1900 billion units of solar power annually that is sufficient to fulfill the entire annual power demand even in 2030. Having understood this potential, national solar mission has planned to increase the installed capacity to 100,000 MW by 2030 and to 200,000 MW by 2050. With such high potential and target, solar power is still contributing very little in the generation segment due to several challenges.

On the other hand, on 31<sup>st</sup> December 2013, southern region grid was connected to central grid in synchronous mode with the commissioning of 765 kV Raichur-Solapur transmission line thereby achieving 'one nation' - 'one grid' concept. All future generations need to be synchronized to the grid and this complicates the development of solar power generation as synchronizing solar power to grid has key technical issues to be addressed to ensure power quality and reliability. This concept further questions the future of solar generation as the target is increasing on one side and the challenges keeps adding equally on the other side.

The main challenge in SPV grid integration is the frequency dependent parameters like synchronization, active and reactive power control, load frequency control etc. This is due to the fact that frequency control in all other

types of generation is based on the speed control of generators where as in SPV system there is no generator which defeats the concept of frequency control using speed.

This research work is aimed in addressing the challenges faced in synchronization of SPV to the grid. The main objective of this research work is to propose a synchronization technique which can provide better quality power during commonly occurring grid disturbances like harmonics and load fluctuations. Synchronized reference frame phase locked loop (SRF-PLL) technique of synchronization is proposed in this work. SRF-PLL technique is subjected to various scenarios and the results are verified for compliance with IEC / IEEE and ANSI standards. Moreover the existing techniques like zero cross detection (ZCD) technique and charge pump phase locked loop (CP-PLL) technique are also analyzed and a comprehensive analysis between the existing and proposed techniques is discussed. The advantages and disadvantages of each technique with respect to standards have been pointed out.

Before proceeding with the synchronization technique it is mandatory to design a SPV system and other electrical equipment to feed power to the grid. The mathematical model provides the flexibility of varying the insolation and temperature and hence any kind of real time scenario can be simulated. The equations governing SPV system is listed out along with the results. The results are verified for proper functionality of the mathematical model.

The peak power varies for both irradiation and temperature. The short circuit current decreases with respect to decrease in irradiation, whereas open circuit voltage deviation is less with respect to change in irradiation. It is also observed that change in temperature affects the open circuit voltage point to a larger extent but has a lesser impact on the short circuit current. For the above said reasons a DC-DC converter with maximum power point tracking (MPPT) algorithm is used to ensure that the SPV works at maximum efficiency. In this work, perturb and observe (P&O) and incremental conductance algorithm is modelled.

The above models results in a constant DC with maximum efficiency from the SPV system. To convert the DC to AC a three phase pulse width



modulation (PWM) inverter is considered. A suitable firing technique which compares modulating and carrier signal to turn on and turn off the insulated gate bipolar transistor (IGBT) is used. The inverter receives pulses for the IGBT by comparing the modulating signal and the carrier signal. The modulating signal is the reference from current and voltage at PCC.

The inverter is connected to a filter tuned for 50 Hz. The filter is connected to a grid coupling transformer which is a step up transformer with on load tap changer mechanism (OLTC) to ensure that the SPV system voltage is higher than the grid voltage to meet IEEE 929 standard thereby ensuring that real power is pumped to the grid from power conditioning unit (PCU). The grid coupling transformer is connected to the grid through a breaker which will be synchronized in line with ANSI 25 standard. PCU is the integral unit which comprises of the SPV system, DC-DC converter, inverter, filter and transformer. The point where the PCU is tied to the grid is called the point of common coupling (PCC).

SRF technique is the process of converting a rotating quantity into a stationary quantity by the process of rotating the angle of reference. The above concept can be better understood by considering a three phase generator rotating at synchronous speed. The axis of the rotor rotates continuously and hence the poles are continuously displaced by an angle which varies continuously. One can assume a reference frame which also rotates at synchronous speed. The three poles which were rotating earlier is now stationary with respect to this reference frame. This concept is called stationary reference frame or synchronous reference frame. This method was proposed by Clark and it is also called as Clark's transformation. The abc rotation of a three phase signal is converted to direct-quadrature-zero (dq0) quantities. The advantage of this conversion is simplification of calculation as an AC quantity is treated as a DC quantity thereby reducing trigonometric and geometric manipulations.

In SRF-PLL technique the grid current is utilized for magnitude reference at the PCC. The bus voltage is utilized for angle estimation. These values are

subjected to Clark's transformation and the converted dq0 quantities are tuned using proportional-integral (PI) controllers. The PI controller tunes the reference signal for magnitude, angle and frequency components as per the grid reference eliminating harmonics. Power system faults that create a turbulence and unbalance for few cycles does not affect the system response, as the PI controllers do not react instantaneously for drastic changes. This suppresses the turbulence of the PCU, failing which the chances of grid islanding and cascaded tripping due to under frequency protection could result. It may further lead to a blackout scenario.

SRF-PLL with two digital filters namely low pass filter (LPF) and moving average filter (MAF) were also introduced to verify the response of the system for harmonics in the PCC. SRF-PLL technique without filter meets IEC 61727 and IEEE 1547 harmonic suppression standard, however with LPF or with MAF certain harmonics are considerably reduced to very low values and hence any type of filter can be used with SRF-PLL depending upon the application. Specific values of these suppressed harmonics are specified in this work. As the above two filters are digital, they do not increase the space requirement. The analog version of the above filters would be bulkier in nature thereby increasing the space and further complications in protection schemes.

## TABLE OF CONTENTS

CHAPTER	CONTENTS	PAGE
<b>1.</b>	<b>INTRODUCTION</b>	1
1.1	Overview	1
1.2	Background	1
1.3	Power Scenario in India	3
1.4	Solar Photovoltaic System	5
1.4.1	Solar Cell	5
1.4.2	Solar Panel	5
1.4.3	Solar Array	5
1.4.4	Types of SPV System	6
1.5	Research Motivation	8
1.6	Organization of the Thesis	9
<b>2.</b>	<b>LITERATURE REVIEW</b>	10
2.1	Introduction	10
2.2	Summary of Literature Survey	10
2.3	Identification of Gap in Literature	11
2.3.1	Existing Challenges	11
2.3.2	Process Complications	12
2.4	Focus of the Research	13
2.5	Objectives and Scope of the Research	13
2.6	Outline of Research Methodology	14
2.7	Contribution of the Research	17
2.8	Conclusion	17

<b>3.</b>	<b>MODELLING AND SIMULATION OF SOLAR PHOTOVOLTAIC SYSTEM WITH POWER CONVERTERS</b>	<b>18</b>
3.1	Introduction	18
3.2	Mathematical Modelling of Solar Photovoltaic System	19
3.3	Design and Simulation of DC-DC Converter	27
3.4	Simulation of Maximum Power Point Tracking	29
3.5	Design and Simulation of Pulse Width Modulated Inverter	33
3.6	Conclusion	36
<b>4.</b>	<b>DESIGN AND SIMULATION OF GRID CONNECTED PHOTOVOLTAIC SYSTEM</b>	<b>37</b>
4.1	Introduction	37
4.2	Design of Filter and Grid Coupling Transformer	37
4.3	Design of Grid and Synchronization Check	40
4.4	Measurement of Grid Parameters	43
4.5	System Interfacing	45
4.6	Synchronization Techniques	46
4.6.1	Zero Crossing Detection Technique	46
4.6.2	Charge Pump Phased Lock Loop Technique	48
4.6.3	Synchronized Reference Frame Phase Locked Loop Techniques	57
4.6.3.1	Design of Low Pass Filter	60
4.6.3.2	Design of Moving Average Filter	64
4.7	Conclusion	68
<b>5.</b>	<b>RESULTS AND DISCUSSION</b>	<b>69</b>
5.1	Introduction	69
5.2	Compliance of Results as per IEEE 929 Standard	69

5.3	Compliance of Results as per IEC 61727 / IEEE 1547 Standard	70
5.4	Compliance of Results as per ANSI C.84.1/ANSI 25 Standard	70
5.5	Comparison of Results of Existing and Proposed Techniques against Various Standards	71
5.6	Conclusion	72
<b>6.</b>	<b>CONCLUSIONS AND RECOMMENDATION</b>	<b>73</b>
6.1	Conclusions	73
6.2	Recommendation for Future Work	74
	<b>REFERENCES</b>	<b>75</b>
	<b>APPENDIX 1 – IEEE 929 Standard</b>	<b>115</b>
	<b>APPENDIX 2 – IEC 61727 Standard</b>	<b>119</b>
	<b>APPENDIX 3 – IEEE 1547 Standard</b>	<b>121</b>
	<b>APPENDIX 4– ANSI 25 Standard</b>	<b>123</b>
	<b>LIST OF PUBLICATIONS</b>	<b>125</b>
	<b>VITAE</b>	<b>126</b>

## LIST OF FIGURES

FIGURE	CAPTION	PAGE
1.1	Graphical Representation of Energy Resources in India	2
1.2	Renewable Installed Capacity in India	2
1.3	Planned Installation Capacities from Solar Energy in India	3
1.4	Irradiance Distribution in India	4
1.5	Solar Array Combinations	6
1.6	Direct-Coupled PV System	6
1.7	Stand-Alone PV System	7
1.8	Grid Connected PV System	8
2.1	Relationship between Current and Frequency	12
2.2	Project Overview	14
2.3	Steps involved in Research	15
2.4	Steps involved in Simulation	16
3.1	Schematic Diagram of the Grid Connected SPV	18
3.2	MatLab Model for Constants Declaration based on SPV Cell	20
3.3	MatLab Model for $I_m$	21
3.4	MatLab Model for $I_o$	21
3.5	MatLab Model for $V_{ta}$	22
3.6	MatLab Model for $I_{pv}$	22
3.7	MatLab Model for $I_{pvn}$	23
3.8	Simulink Equivalent Circuit of SPV System	23

3.9	PV Characteristics Measurements using Simulink Model	24
3.10	Characteristics of Single PV Panel at $G = 1000\text{W/m}^2$ and $T=40^\circ\text{C}$	25
3.11	Characteristics of Single PV Panel at $G=800\text{W/m}^2$ and $T=40^\circ\text{C}$	25
3.12	Characteristics of Single PV Panel at $G=500\text{W/m}^2$ and $T=40^\circ\text{C}$	25
3.13	Characteristics of Single PV Panel at $G=1000\text{W/m}^2$ and $T=25^\circ\text{C}$	26
3.14	Characteristics of Single PV Panel at $G=1000\text{W/m}^2$ and $T=30^\circ\text{C}$	26
3.15	Characteristics of Single PV Panel at $G=1000\text{W/m}^2$ and $T=40^\circ\text{C}$	27
3.16	Simulink Model for DC-DC Boost Converter	28
3.17	Input and Output Voltage of Boost Converter	28
3.18	Block Diagram of the MPPT	29
3.19	Flowchart for P&O Algorithm	30
3.20	Simulink Model of P&O Algorithm	31
3.21	Flowchart for INC MPPT Algorithm	32
3.22	Simulink Model of INC algorithm	33
3.23	Simulink Model for Three-Phase Inverter	35
3.24	Inverter Output after Filter for a Constant 250 V DC	36
4.1	Simulink Model for Filter	37
4.2	Wave Form before Filter	38
4.3	Wave Form after Filter	38
4.4	Grid Coupling Transformer	39

4.5	MatLab Models of Grid and Three-Phase Load	41
4.6	Simulation Model for Synchronization Check	42
4.7	Frequency, Magnitude and Angle Difference without Synchronization	43
4.8	Frequency, Magnitude and Angle Difference with Synchronization	43
4.9	Simulink Model P and Q Measurement	44
4.10	Solar Voltage Measurement	44
4.11	Grid and Solar Active Power Measurement	44
4.12	Grid and Solar Reactive Power Measurement	45
4.13	Grid and Solar Three-Phase Current Measurement	45
4.14	Simulink Model for Three-Phase Output from Solar Panel	46
4.15	Zero Cross Simulink Model	47
4.16	Zero Cross Pulse Output for 50 Hz Fundamental Frequency	47
4.17	Zero Cross Pulse Output for 50 Hz Fundamental Frequency and 150 Hz Harmonic	47
4.18	Schematic Representation of the System	49
4.19 (a)	Basic Operation of PLL	49
4.19 (b)	MatLab Implementation of CP-PLL	50
4.20	MatLab-Simulink Model of the System shown in Fig.4.18	51
4.21	Tracking Characteristics of INC MPPT Algorithm	52
4.22	Voltage Spectrum at PCC	53
4.23	THD of Voltage at PCC	54
4.24	Current Spectrum at PCU in CP-PLL Technique	54



4.25	THD Measured at PCU in CP-PLL Technique	54
4.26	CP-PLL Output Displaying the Suppression of Phase Difference between Grid and Inverter Voltage under Normal Frequency Condition	56
4.27	CP-PLL Output Displaying the Suppression of Phase Difference between Grid and Inverter Voltage under Disturbance Conditions	57
4.28	Simulink Model of SRF-PLL	58
4.29	Harmonic Rich Input Voltage Spectrum for SRF-PLL	59
4.30	Output Voltage Spectrum for SRF-PLL	59
4.31	Second Harmonic Input Voltage Spectrum for SRF-PLL	59
4.32	Output of SRF-PLL Method for 100Hz (2 <sup>nd</sup> Harmonic)	60
4.33	Simulink Design of Low Pass Filter	61
4.34	FFT of Unbalance Input Spectrum for SRF-PLL	61
4.35	FFT of the Output Spectrum Measured after LPF	62
4.36	Harmonic Rich Input Voltage Spectrum for SRF-PLL	62
4.37	FFT of the Harmonic Rich Input Spectrum for SRF-PLL	63
4.38	Output Voltage Spectrum for SRF-PLL Designed with Low Pass Filter	63
4.39	FFT for SRF-PLL designed with Low Pass Filter	63
4.40	Simulink Design of Moving Average Filter	64
4.41	FFT of the Output Spectrum Measured after MAF	65
4.42	Output Voltage Spectrum for SRF-PLL Designed with MAF	65
4.43	FFT for SRF-PLL Designed with MAF	66

## LIST OF TABLES

<b>TABLE</b>	<b>CAPTION</b>	<b>PAGE</b>
1.1	Five Years Plan of India	1
1.2	Solar Potential in India	5
2.1	Classification of Literature Survey	10
3.1	Power, Current and Voltage Measurement for Different Irradiation at Constant Temperature	26
3.2	Power, Current and Voltage Measurement for Different Temperature at Constant Irradiation	27
4.1	Simulation Parameters for the Proposed System	50
4.2	Synchronization Standards for SPV Inverter Fed Grid Systems	53
4.3	Current Harmonics Distortion of CP-PLL Method for Different Cases	55
4.4	Current Harmonics Distortion of SRF-PLL with and without Filter	67

## LIST OF SYMBOLS

G	Insolation level $W/m^2$
$G_n$	Nominal insolation level ( $1000 W/m^2$ )
$I_d$	Diode reverse saturation current in the equivalent circuit ( $\mu A$ )
$I_m$	Photon generated current
$I_{pv}$	Solar PV module current (A)
$I_{pvn}$	Photovoltaic current at nominal condition
$I_{sc}$	Short circuit current of the module (A)
$I_{sh}$	Current through the shunt resistance (mA)
K	Boltzman's constant ( $1.381 \times 10^{-23} J/K$ )
$K_i$	Temperature co-efficient of short circuit current
$N_{pp}$	No. of cells in parallel
$N_{ss}$	No. of cells in series
$\omega$	Angular velocity
q	Electronic charge ( $1.602 \times 10^{-19} C$ )
$R_s$	Series resistance in $\Omega$
T	Temperature in degrees
$V_{ocn}$	Open circuit voltage of the module (V)

## LIST OF ABBREVIATIONS

AC	Alternating Current
ANSI	American National Standard Institute
CCM	Continuous Conduction Mode
CEA	Central Electricity Authority
CP-PLL	Charge Pump Phase Lock Loop
DC	Direct Current
DQ0	Direct Quadrature Zero
FFT	Fast Fourier Transformation
IEC	International Electrotechnical Commission
IEEE	Institute of Electrical and Electronic Engineering
IGBT	Insulated Gate Bipolar Transistor
INC	Incremental Conductance
LPF	Low Pass Filter
MAF	Moving Average Filter
MPPT	Maximum Power Point Tracking
NTPC	National Thermal Power Corporation
OLTC	On Load Tap Changer
P&O	Perturb and Observe
PCC	Point of Common Coupling
PCU	Power Conditioning Unit
PGCIL	Power Grid Corporation of India Limited
PLL	Phase Locked Loop
PWM	Pulse Width Modulation
SPV	Solar Photovoltaic
SRF-PLL	Synchronous Reference Frame Phase Locked Loop
THD	Total Harmonic Distortion
ZCD	Zero Crossing Detection

# CHAPTER 1

## INTRODUCTION

### 1.1 OVERVIEW

In recent years micro electric power systems with solar photovoltaic (SPV) generation has increased with deregulation and liberalization of the power market. In such circumstances the environment surrounding the electric power industry has become more complicated. Providing high quality power in a stable manner has become one of the important requirements. Grid parameters control is the system-wide indicator of overall power imbalance. The problem of power injection by variable renewable sources must be investigated for various demand conditions.

### 1.2 BACKGROUND

Energy is one of the major inputs for the economic development of any country. In the case of developing countries, the energy sector assumes a critical importance in view of the ever-increasing energy needs requiring huge investments to meet them.

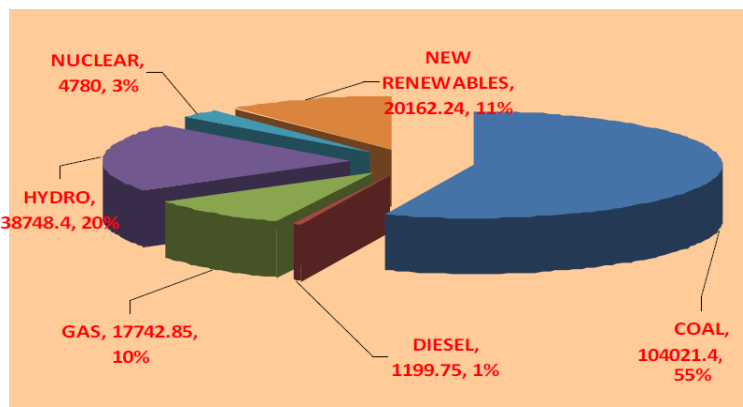
The increasing power demand and the deficit can be felt by the frequent power cuts in major cities or understood from statistics provided by central electricity authority (CEA) of India [Central Electricity Authority, 2012]. Table 1.1 shows the actual installed capacity and the planned capacity for 10<sup>th</sup>, 11<sup>th</sup> and 12<sup>th</sup> five year plan of India. It can be seen that there is nearly 50 % increase in the demand between the 10<sup>th</sup> and the 11<sup>th</sup> five years plan and the trend continues.

**Table 1.1 Five Years Plan of India [1]**

<b>5 Years Plan</b>	<b>Target (MW)</b>	<b>Achieved (MW)</b>	<b>Success rate</b>
10 <sup>th</sup> (2002-2007)	34,000	21,180	62 %
11 <sup>th</sup> (2007-2012)	62,000	54,964	89 %
12 <sup>th</sup> (2012 -2017)	76,000	-	-

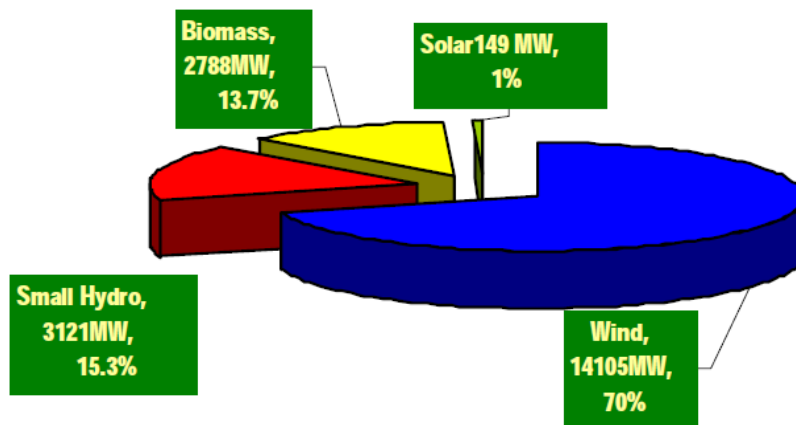
World oil and gas reserves are estimated at just 45 years and 65 years respectively. Coal is likely to last a little over 200 years. [Bureau of Energy Efficiency, 2005]

Fig. 1.1 shows that out of the total capacity of energy resources only 11 % is from renewable energy. Fig. 1.2 shows that 14,105 MW has been generated from wind power and 3,121 MW from hydro whereas only 149 MW from solar. Hence, it is imperative that there is a shift of focus from conventional fossil fuels to renewable sources like wind, PV etc. for power generation. Hence, the national solar mission (NSM) has planned to increase the installed capacity to 100,000 MW by 2030 and to 200,000 MW by 2050. [Central Electricity Authority, 2012]



Capacity of Renewables is available only up to 30.06.2011

**Fig. 1.1 Graphical Representation of Energy Resources in India**



Capacity of Renewables is available only up to 30.06.2011

**Fig. 1.2 Renewable Installed Capacity in India**

In India, out of the 11 % of energy being generated from renewable sources, 70 % comes from wind and only 1 % is being supplied by solar. But, India being a tropical country, there is huge potential for tapping solar energy. In lieu of this, on 31<sup>st</sup> December 2013, southern region was connected to central grid in synchronous mode with the commissioning of 765 kV Raichur-Solapur transmission line thereby achieving ‘one nation’-‘one grid’-‘one frequency’. All future generation has to be tied to the grid on “one nation – one grid” concept [2]. There is a need for proper technology to synchronize solar power to the grid. This work is focused toward this requirement.

For this work, issues related to grid connected systems have been addressed. The focus points of grid connected system are,

- The grid is subjected to variable load
- A trip command issued by a relay to a major load would often result in power swing and the input from the SPV needs to be stable during this period
- Loss of a generator in the grid would result in power swing and the input from the SPV needs to be stable during this period

### 1.3 POWER SCENARIO IN INDIA

The need of the hour is to move towards non-conventional energy resources and green energy. Kyoto protocol has fixed targets for the emission of greenhouse gases. Solar energy being a clean and green source of energy will be the future for power generation. Fig. 1.3 shows the planned installation capacity from solar.

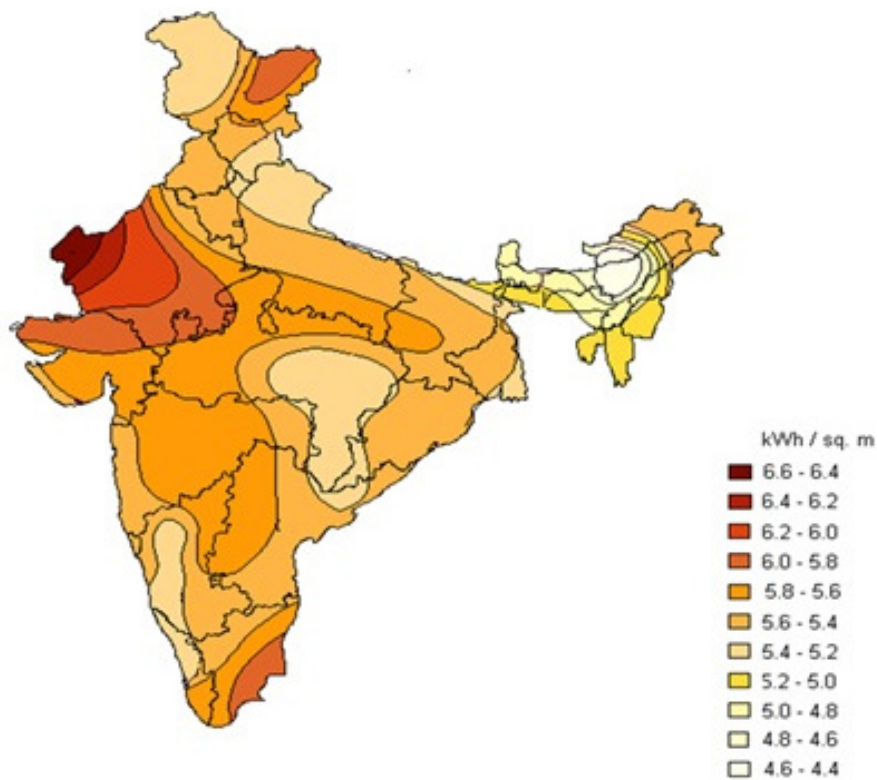


**Fig. 1.3 Planned Installation Capacities from Solar Energy in India  
Target for Indian Government in 2022:20 GW from Solar Power [3]**

## Potential of Solar Power in India

India is in a state of perennial energy shortage with a demand-supply gap of almost 12 % of the total energy demand. This trend is significant in the electricity segment that is heavily dependent on coal and other non-renewable sources of energy. Renewable energy sources contribute only 11 % of the total installed power capacity of 167,077 MW in India.

Solar energy potential in India is immense due to its convenient location near the equator. India receives nearly 3000 hours of sunshine every year, which is equivalent to 5000 trillion kWh of energy. Fig. 1.4 shows the irradiation distribution in India. As given in Table 1.2., India can generate over 1900 billion units of solar power annually which is enough to fulfill the entire annual power demand even in 2030.



**Fig. 1.4 Irradiance Distribution in India [4]**



**Table 1.2 Solar Potential in India [4]**

Total Land Area (sq km)	3,287,590
No. of Sunny Days	200
Unit Potential from 1 sq m	4 kWh/day
Conversion Efficiency	15 %
1 sq. km (Mn units per year)	120
0.5 % of Land Used (in sq km)	16,438
Potential Units (in billions)	1,972

## **1.4 SOLAR PHOTOVOLTAIC SYSTEM**

### **1.4.1 SOLAR CELL**

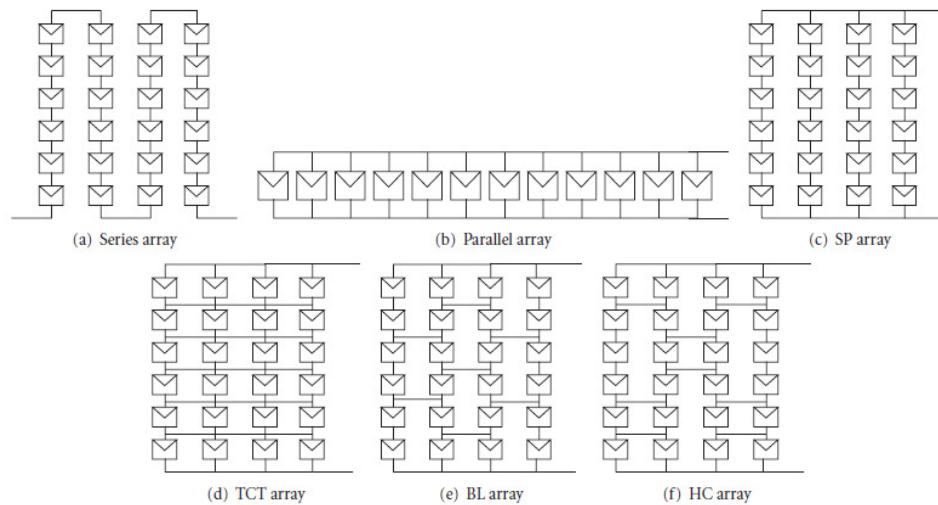
Solar cell is a device which converts light energy to electric energy by the principle of photovoltaic effect. Photovoltaic generation is caused as a result of electromagnetic radiation which separates positive and negative charge carriers in absorbing materials. In the presence of electric field, these charges can produce current. Such fields permanently exist at junctions in photovoltaic cells as in built electrostatic fields and provide electromotive force.

### **1.4.2 SOLAR PANEL**

A set of SPV modules which are connected electrically is called a solar panel.

### **1.4.3 SOLAR ARRAY**

A combination or group of solar panels connected together constitutes an array. Array can be connected in series or parallel based on the application. When there is a need to increase the voltage, panels in series are increased. When there is a need to increase the current, panels in parallel are increased. Fig 1.5 shows the different and commonly used SPV array arrangements such as series, parallel, series-parallel (SP), total cross tied (TCT), bridge linked (BL) and honey comb (HC). [Ramaprabha R. and Mathur B.L., 2009]



**Fig. 1.5 Solar Array Combinations**

#### 1.4.4 TYPES OF SPV SYSTEM

SPV system are classified into the following three types

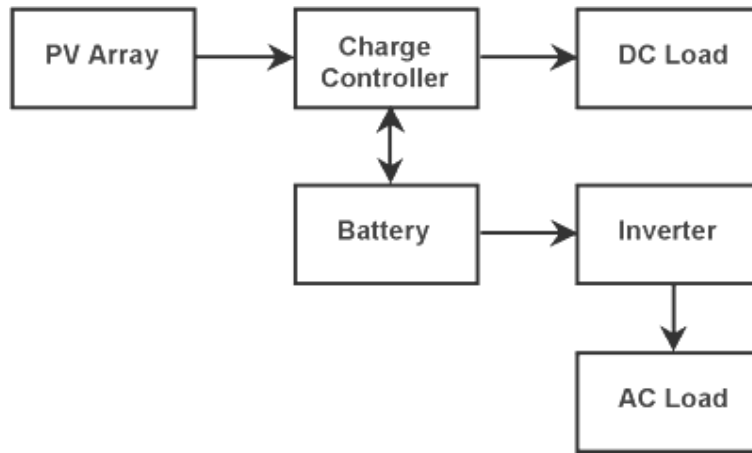
1. Stand-alone system
2. Utility interactive / Grid connected system

##### 1. Stand-Alone system

Stand-alone systems are designed for independent operation of the electric utility grid. It can be designed for DC or for AC loads. This system has very less design challenges as they are not dependent on complicated control techniques. Fig. 1.6 and Fig. 1.7 show different methods of connecting PV array to load.



**Fig. 1.6 Direct-Coupled PV System**



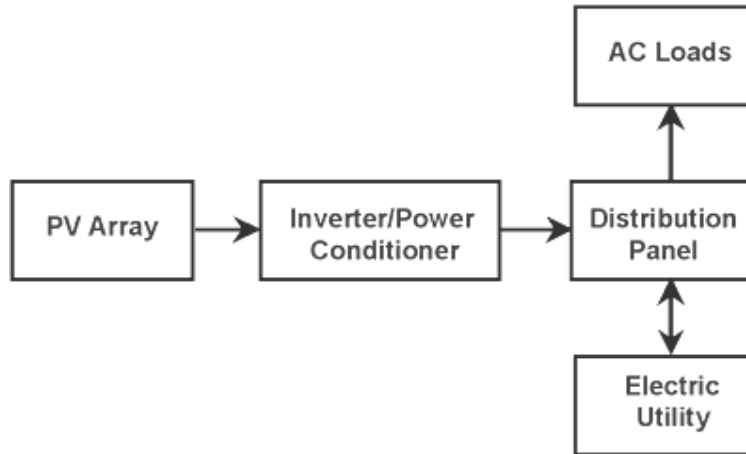
**Fig. 1.7 Stand-Alone PV System**

Stand-alone system can be used in rural electrification as it is challenged by transmission of power in remote areas. Civil construction of power transmission equipment across rugged geographical condition and maintenance adds to the challenges. Stand-alone system overcomes this disadvantage as they can generate power in the same location. It also eliminates the transmission losses and power theft issues that will occur in transmission of power through remote areas.

This system being dependent on solar as the only source, it can produce power only during day time and it is also not reliable since it depends on a natural resource which is not under our control. Change in weather conditions can pull out the system from service.

## **2. Grid Connected System**

Grid connected systems also known as utility-interactive PV systems operate in parallel with the grid. Power conditioning unit (PCU) is the primary component in this kind of system. The system operates in parallel to the grid and hence it shares the load depending on availability of sun light. Fig 1.8 shows the block diagram of grid connected PV array.



**Fig. 1.8 Grid Connected PV System**

In grid integrated system the availability of power is not purely dependent on the natural parameter and hence the reliability is more compared to stand-alone system. Proper planning and design of this system would lead to very high reliability and can meet the growing demand of a Nation where there is lack of power generation.

This performance can be affected by various disturbances in the grid such as a power system fault, load throw, frequency fluctuation and harmonics. All these parameters are common scenarios in the grid and a high level controller needs to be utilized to ensure proper performance and quality. This results in complicated design of converters, failing which the system would be pulled out of synchronization from the grid [5].

### **1.5 RESEARCH MOTIVATION**

When solar, wind or hydro power is used for generating power, the challenges of grid control is greater since the natural parameters like intensity of the Sun's ray, velocity of the wind and force of the water falls cannot be controlled. Solar power generation has greater challenges in this area as many other factors like partial clouding, sudden change in weather condition etc. can affect the system.

The motivation factors behind this work are,

1. Major cities in India are experiencing power cut which is a clear proof of the lack of generation. With this capacity we cannot imagine about

rural electrification until some alternate source of energy is available without any challenges in grid interconnection.

2. This research work will be for a good social cause and can be used as a reference guide by PGCIL, NTPC and other organizations that are looking for investment in solar power generation.

## **1.6 ORGANIZATION OF THE THESIS**

**Chapter 1** deals with the current power scenario, its drawbacks and how the growing demand can be met by the use of SPV generation. The motivation of the research work is highlighted and the chapter ends with the organization structure of this work.

**Chapter 2** deals with the literature survey undergone to identify the gap in literature and reason for the gap. The list of challenges has been analyzed and the research focus area and objectives were framed. Further the research methodology outline and the contributions of this work are listed.

**Chapter 3** deals with the simulation design procedure of SPV system, maximum power point tracking algorithm, DC-DC converter, inverter and pulse width modulation control technique for inverter firing pulse generation. The simulation models, design parameters and the test results are tabulated.

**Chapter 4** deals with the design of grid parameters. Filter, transformer, synchronization verification relay and measurement blocks for displaying grid parameters are designed. Control techniques which can be used to simulate the existing and proposed synchronization techniques with suitable filters have been designed. The designed model has been subjected to various grid scenarios and the responses are recorded.

**Chapter 5** deals with IEEE / IEC and ANSI standards prescribed for grid interactive inverters. The compliance of the results recorded in chapter 4 is discussed.

**Chapter 6** concludes the discussion by summarizing the various synchronization techniques and its results. On comparison of the results with standards we can conclude that SRF-PLL synchronization technique meets the standards for worst case grid disturbance.

## CHAPTER 2

### LITERATURE REVIEW

#### 2.1 INTRODUCTION

In this chapter national and international papers related to SPV system, grid control and other techniques related to SPV is referred. The gap in literature is found to be the control of frequency related parameters in SPV. In the further sections the relationship between speed and frequency is high-lighted. Synchronization being one of the major techniques which depends on frequency, the challenges in synchronizing SPV system to the grid is identified and the objective of this research is framed.

#### 2.2 SUMMARY OF LITERATURE SURVEY

Table 2.1 gives brief summary of literary survey. The survey is based on broad themes in power generation using SPV cells.

**Table 2.1 Classification of Literature Survey**

S.No	Theme	No. of Papers	
		International	National
1	Stand-Alone SPV System [A]	13	2
2	Control of Grid Connected System [B]	67	9
3	Maximum Power Point Tracking Method [C]	27	4
4	Mathematical Modelling of SPV [D]	19	3
5	Mathematical Modelling of Inverter [E]	19	3
6	Micro Grid Control [F]	20	3
7	Partial Shading Improvements in SPV [G]	9	3

8	SPV Array Re-Configuration Strategy [H]	2	1
	<b>Total</b>	<b>176</b>	<b>28</b>

### 2.3 IDENTIFICATION OF GAP IN LITERATURE

National and international papers published on SPV system are focused in the following areas.

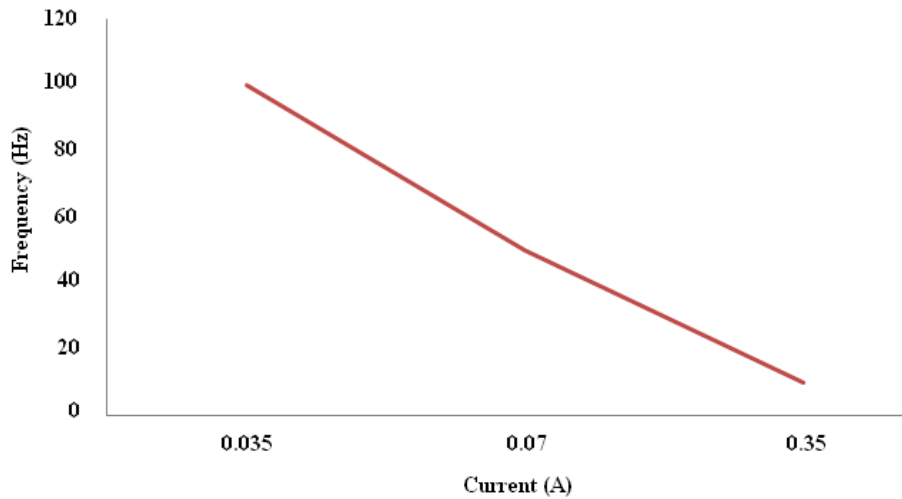
1. Stand-alone SPV system
2. Maximum power point tracking (MPPT) methods
3. Mathematical modelling of SPV
4. Mathematical modelling of inverter
5. Micro grid control
6. Partial shading improvements in SPV
7. SPV array re-configuration strategy

The literature review shows that the connection of SPV system to grid is scarcely discussed. Review of grid connected systems show that most of the methods discussed so far are not integrated with the SPV system. The reason for this gap is due to the fact that integration of SPV system has greater challenges in comparison with other methods of generating power. The areas of challenges are listed below,

1. Synchronization of SPV system to the grid
2. Frequency control without rotating machines
3. Active and reactive power maintenance in grid connected SPV system
4. Variation of SPV characteristics during partial shading conditions

#### 2.3.1 EXISTING CHALLENGES

The relationship between frequency and current can be specified as; frequency is inversely proportional to current. When load increases, frequency decreases and vice versa, which can be observed in Fig. 2.1.



**Fig. 2.1 Relationship between Current and Frequency**

In order to maintain the frequency as a constant the rotating machines use the speed control technique, since speed is directly proportional to frequency.

$$N = 120f / P$$

$$\boxed{N \propto f} \quad (2.1)$$

$$N \propto 1/P$$

The speed control in rotating machines is done by controlling the turbine speed with a suitable closed loop control system. The same concept is true in all rotating machines and hence frequency control is not a great challenge in the following areas.

1. Thermal generation
2. Steam generation
3. Hydroelectric generation
4. Wind power generation
5. Bio gas generation

### 2.3.2 PROCESS COMPLICATIONS

In case of SPV generation, there is no rotating machine and hence the speed and frequency relationship does not exist. This complicates the following process since all these parameters require frequency control.



1. Synchronization
2. Load frequency control
3. Active power control
4. Reactive power control

#### **2.4 FOCUS OF THE RESEARCH**

The fundamental building block for the above-mentioned challenges is the design of grid connected SPV system, synchronizing the SPV system with the grid using better techniques to overcome the challenges in the existing synchronization techniques and measuring various parameters required for grid control. This will be the focus of this research. The existing synchronization techniques are,

- Zero crossing detection (ZCD) technique
- Phase locked oscillator
- Analog phase locked loop (Analog PLL)
- Charge pump phase locked loop (CP-PLL)

#### **2.5 OBJECTIVES AND SCOPE OF THE RESEARCH**

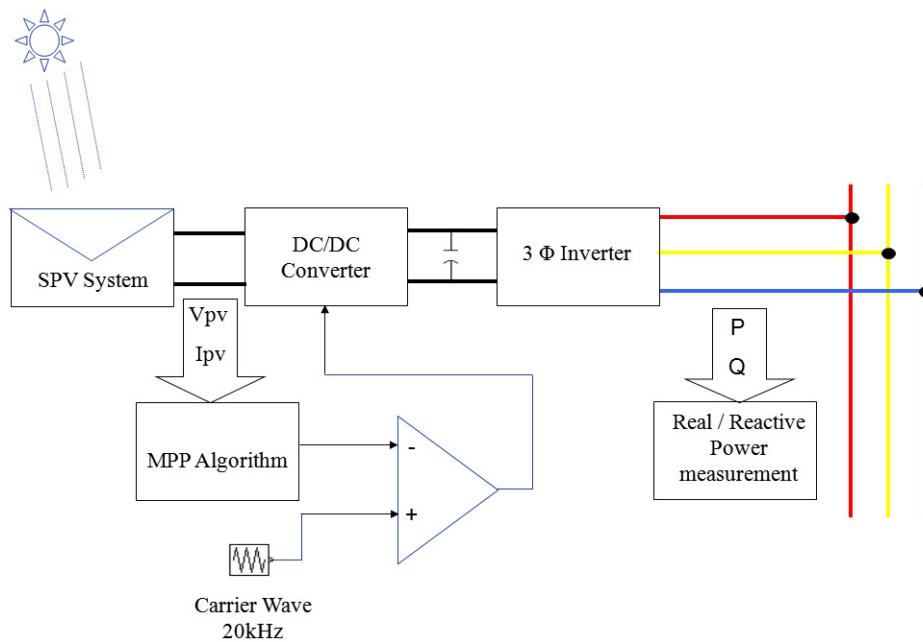
The main objective of this research is

- Design of grid connected photovoltaic system, simulation and validation of models
- Synchronous reference frame phase locked loop (Digital SRF-PLL) method for real time grid synchronization techniques
- Measuring various parameters required for grid control

In this work an attempt has been made to design and synchronize the SPV system to grid based on the grid conditions.

## 2.6 OUTLINE OF RESEARCH METHODOLOGY

Fig 2.2 overviews the proposed work.

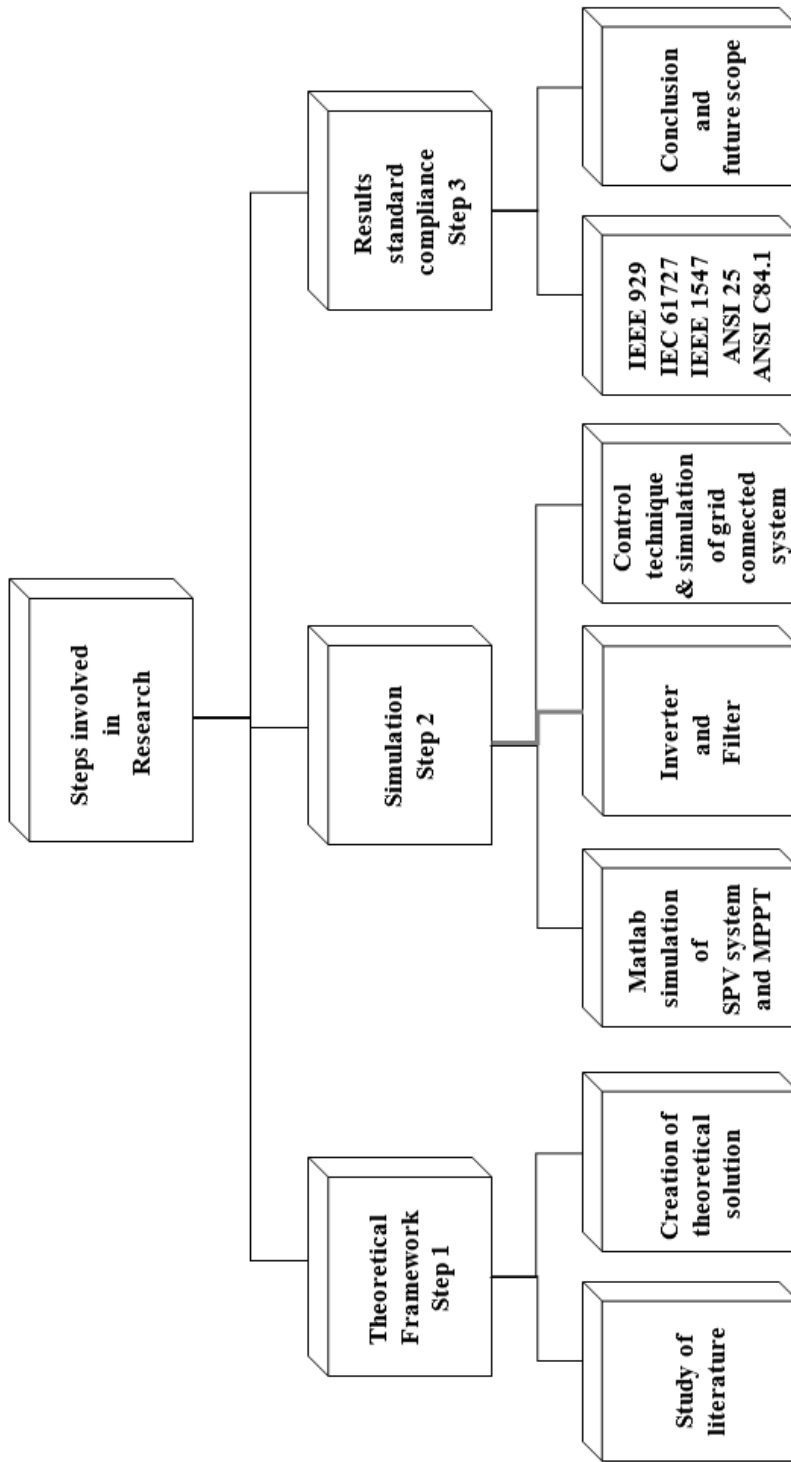


**Fig. 2.2 Project Overview**

The methodology of the research work is as follows:

1. Modelling and simulation of SPV array using Matlab
2. Study and implementation of MPP algorithm
3. Design of boost converter to track MPP
4. Design of filter
5. Simulation of existing synchronization techniques
6. Synchronization circuit implementation to meet standards for grid connection – *Proposed work*

Fig. 2.3 and Fig 2.4 show the steps involved in the research and simulation respectively.



**Fig. 2.3 Steps involved in Research**

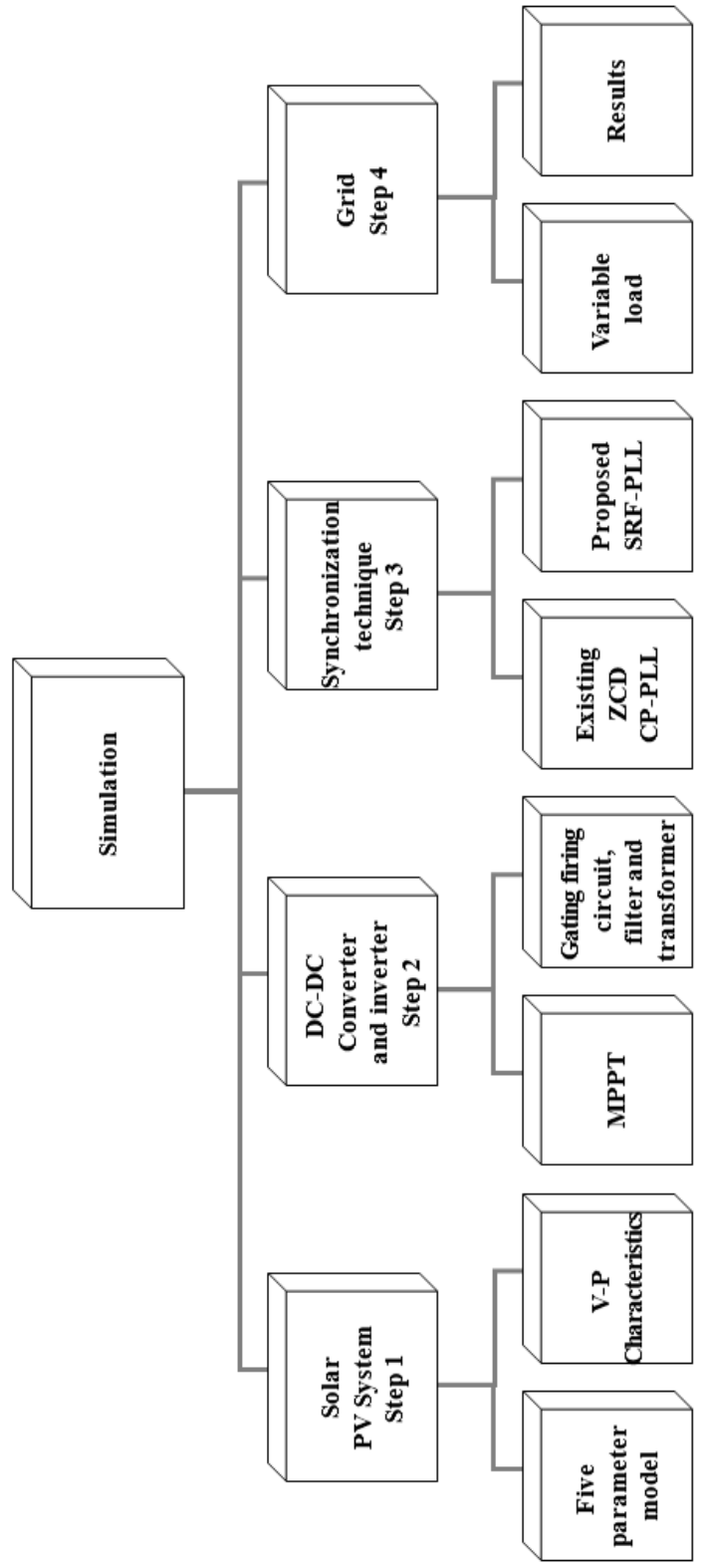


Fig. 2.4 Steps involved in Simulation

## 2.7 CONTRIBUTION OF THE RESEARCH

- A new auto synchronization technique for grid connected PV system has been proposed, verified and the results were found to be in compliance with international standard written for grid interactive inverters (IEEE 929)
- Harmonic analysis has been carried out and the results are found to comply with IEC 61727 standard which can be used for 10 kW system
- Harmonic analysis test has been carried out and the results are found to comply with IEEE 1547 standard and can be used for 30 kW system
- To feed real power from the SPV to the grid, a transformer with OLTC mechanism design steps have been presented which adheres with IEEE 929 standard
- The transformer also takes care of operation of the system in safe voltage limits as specified in ANSI C84.1
- Development of anti-chattering logic for protection
- SRF-PLL synchronization technique with current and voltage reference has been designed and with proper filter the system is subjected to commonly occurring grid scenarios and the performance is verified

## 2.8 CONCLUSION

A detailed review on the existing literature shows that grid connected SPV system is scarcely discussed. A closer view shows that this literature gap is due to the fact that frequency parameter cannot be varied easily. Synchronization being one of the parameter which depends on frequency, it has been chosen as the focus of this research work.

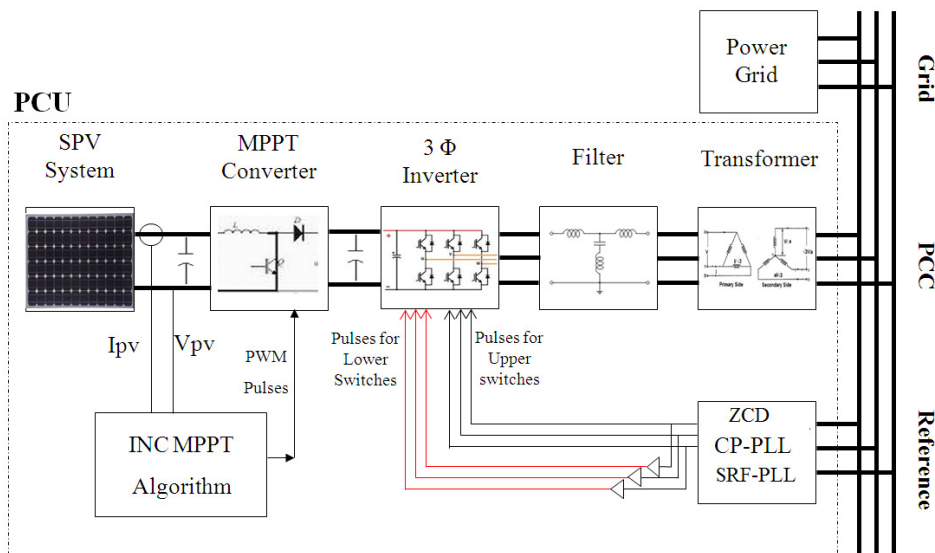
## CHAPTER 3

### MODELLING AND SIMULATION OF SOLAR PHOTOVOLTAIC SYSTEM WITH POWER CONVERTERS

#### 3.1 INTRODUCTION

The scope of this chapter is to design an SPV system to meet the required DC output. The DC is boosted with a DC-DC boost converter as MPPT. An inverter with pulse width modulation technique is also modelled for DC to AC conversion.

Fig. 3.1 shows the schematic diagram of the model. Power conditioning unit (PCU) is an integrated unit which comprises of SPV system, DC-DC converter, three phase inverter, filter and transformer. Point of common coupling (PCC) is the point where the PCU is connected to the grid. The schematic diagram shown above is divided into five groups. Each group is independently simulated and the results are verified.



**Fig. 3.1 Schematic Diagram of the Grid Connected SPV**

- Group 1 : SPV system with MPPT
- Group 2 : Three phase inverter circuit
- Group 3 : PWM modulator
- Group 4 : Filter and transformer
- Group 5 : Power Grid
- Group 6 : Synchronization techniques

Group 1 to 3 has been simulated in section 3.2 to 3.5 of chapter 3.

Group 4 to 6 has been discussed in section 4.2 to 4.7 of chapter 4.

### 3.2 MATHEMATICAL MODELLING OF SPV SYSTEM

A well-known five-parameter model of a SPV cell is considered for this work. The mathematical equations used to simulate the realistic model of SPV cell are given below [Tiwari G.N, 2010].

$$I = I_{pv} - I_d - I_{sh} \quad (3.1)$$

$$I = I_m - I_{sh} \quad (3.2)$$

$$I_m = I_{pv} - I_d \quad (3.3)$$

$$I_m = I_{pv} N_{pp} - I_o N_{pp} [\exp A - 1] \quad (3.4)$$

$$I_o = \frac{[K_i dT + I_{sc}]}{\exp\left(\frac{V_{ocn} + K_v dT}{V_{ta}}\right) - 1} \quad (3.5)$$

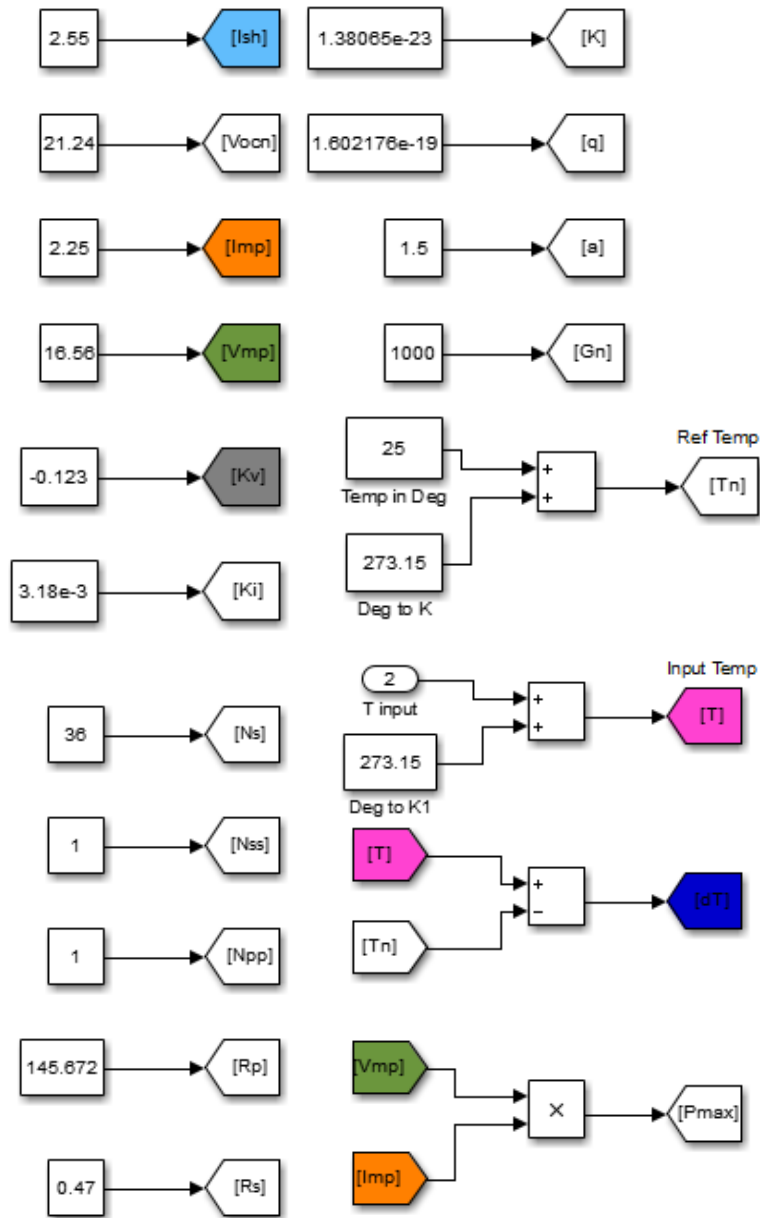
$$A = \frac{V_{meas} + I_{meas} (R_s N_{ss} / N_{pp})}{N_{ss} V_{ta}} \quad (3.6)$$

$$V_{ta} = \frac{aKN_s T}{q} \quad (3.7)$$

$$I_{pv} = [I_{pvn} + K_i dt] \frac{G}{G_n} \quad (3.8)$$

$$I_{pvn} = \frac{[R_s + R_p]}{R_p} I_{sh} \quad (3.9)$$

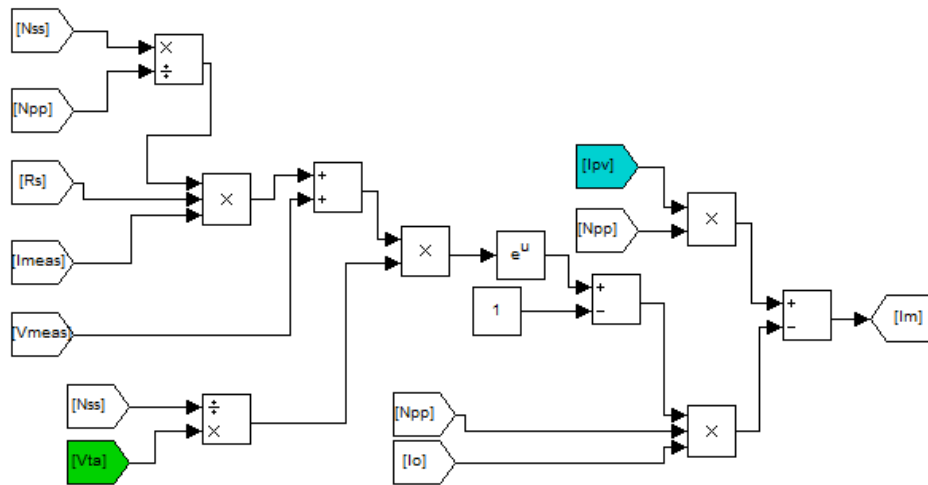
The various constants in the Eqn. (3.1) to (3.9) are defined for MatLab model as shown in Fig. 3.2.



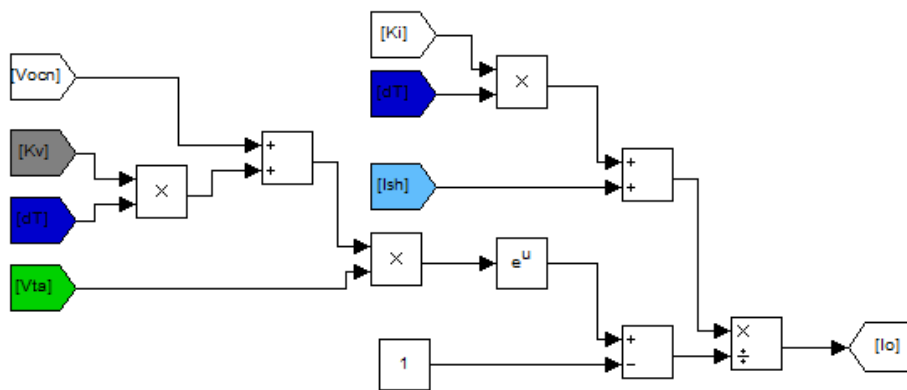
**Fig. 3.2 MatLab Model for Constants Declaration based on SPV Cell**

The Eqns. (3.1) to (3.9) are simulated in MatLab and the simulation models are given in Figs. 3.3 to 3.7.





**Fig. 3.3 MatLab Model for  $I_m$**



**Fig. 3.4 MatLab Model for  $I_o$**

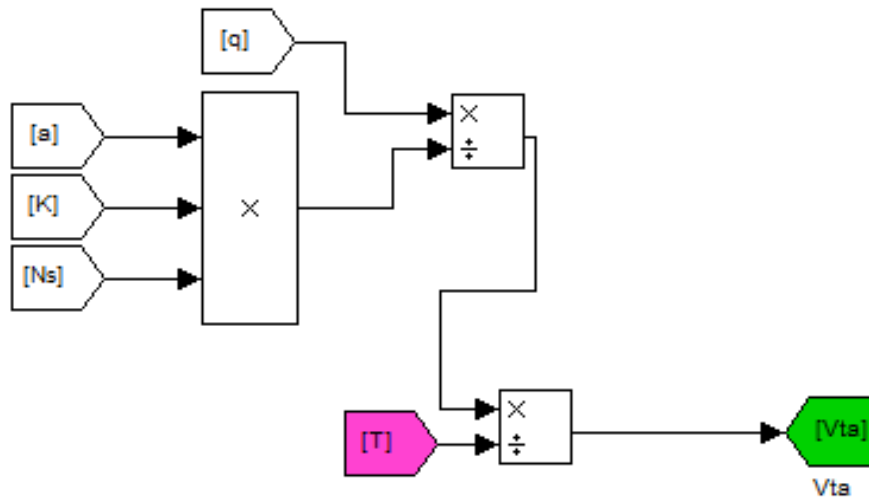


Fig. 3.5 MatLab Model for  $V_{ta}$

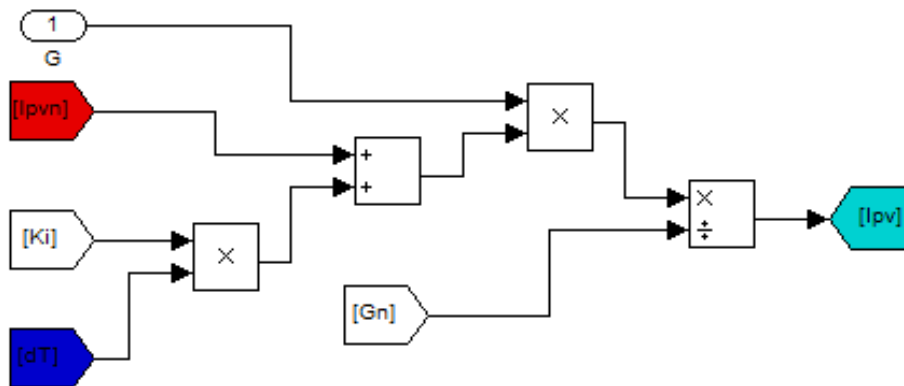
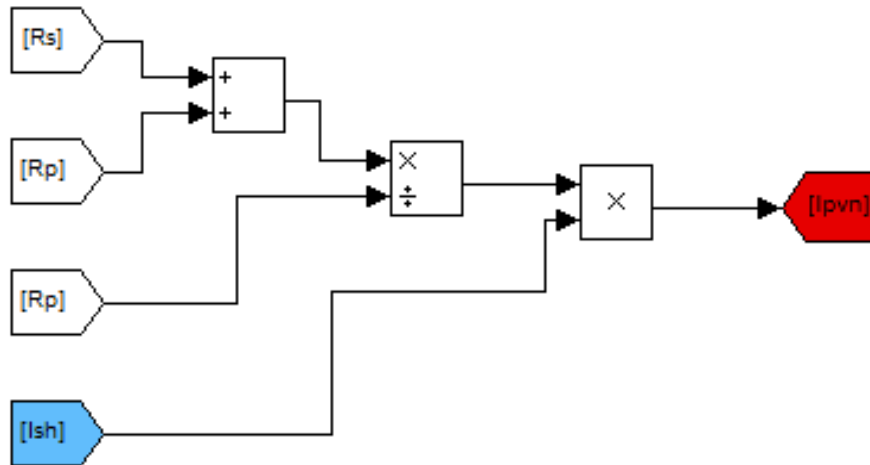


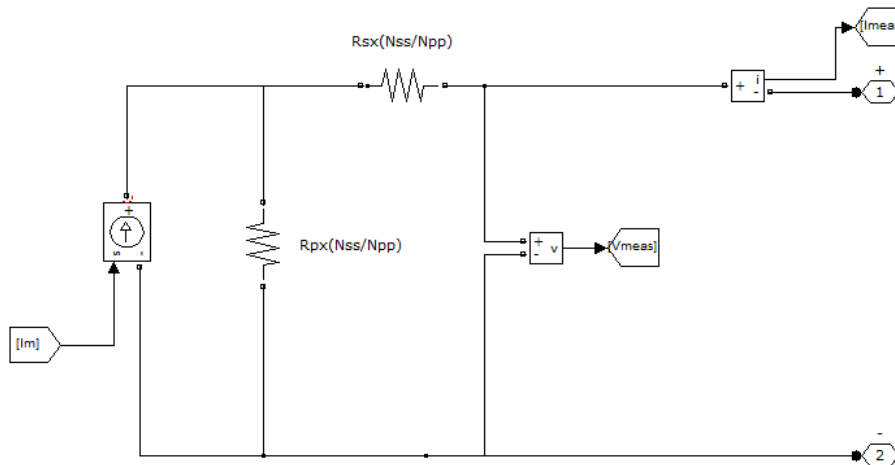
Fig. 3.6 MatLab Model for  $I_{pv}$



**Fig. 3.7 MatLab Model for  $I_{pvn}$**

The equivalent circuit of the SPV cell is simulated in MatLab as shown in Fig. 3.8. The current source in the equivalent circuit gets the  $I_m$  value from the mathematical model, which is simulated as shown in Fig. 3.9.

The irradiation value ( $G$ ) and the temperature ( $T$ ) are varied and the characteristics of SPV system are plotted.



**Fig. 3.8 Simulink Equivalent Circuit of SPV system**

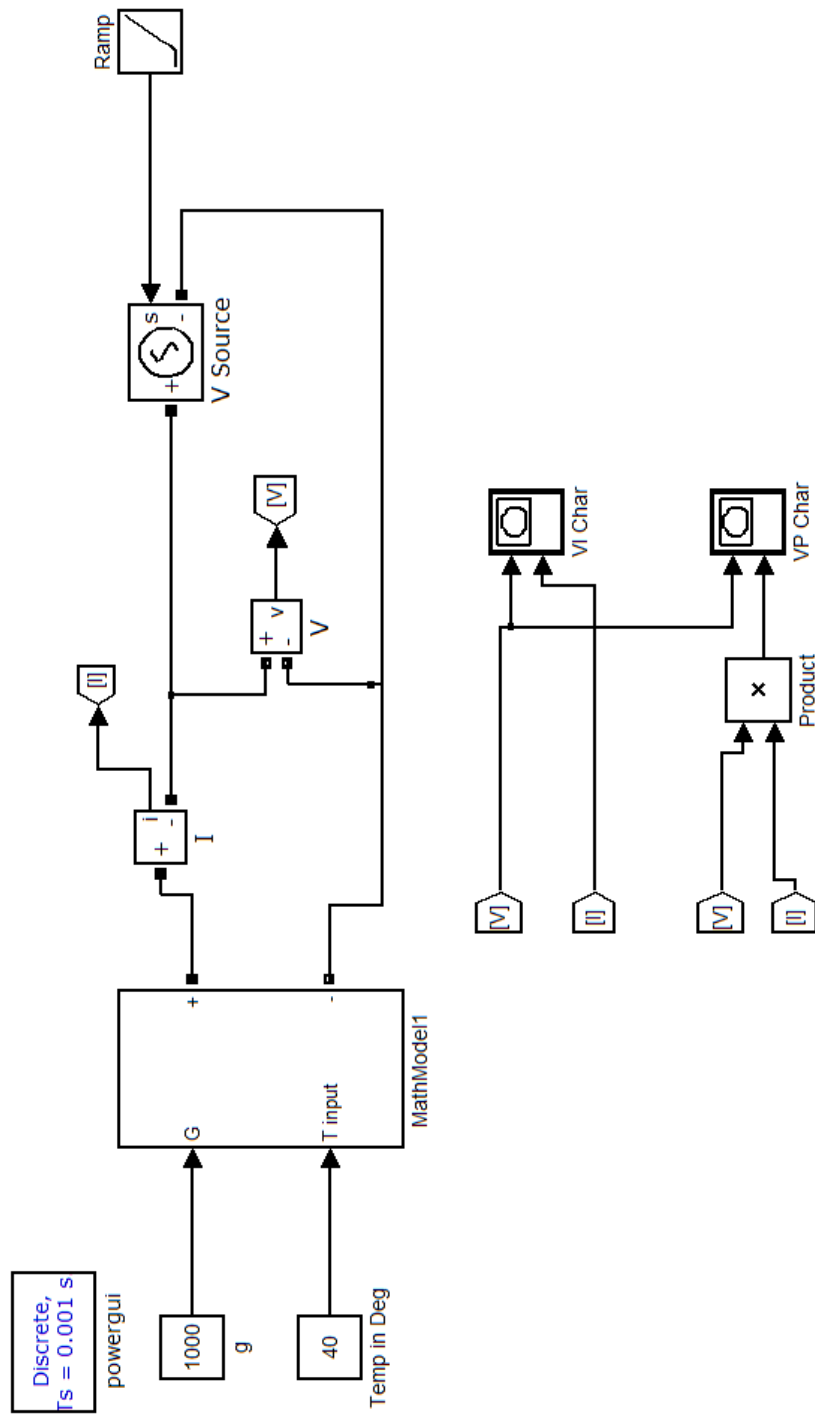
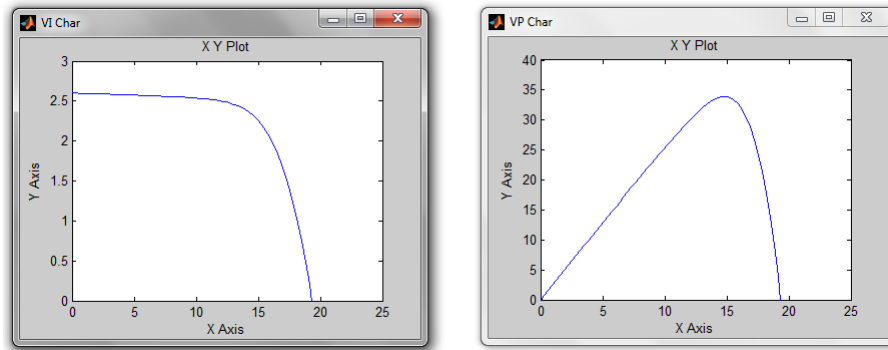


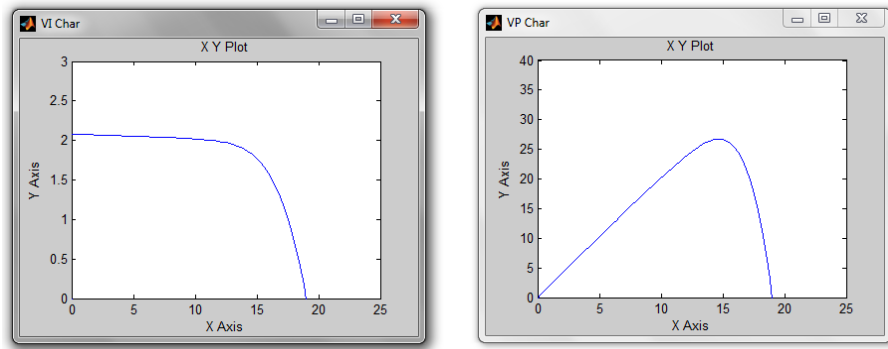
Fig. 3.9 PV Characteristics Measurements using Simulink Model

## Results

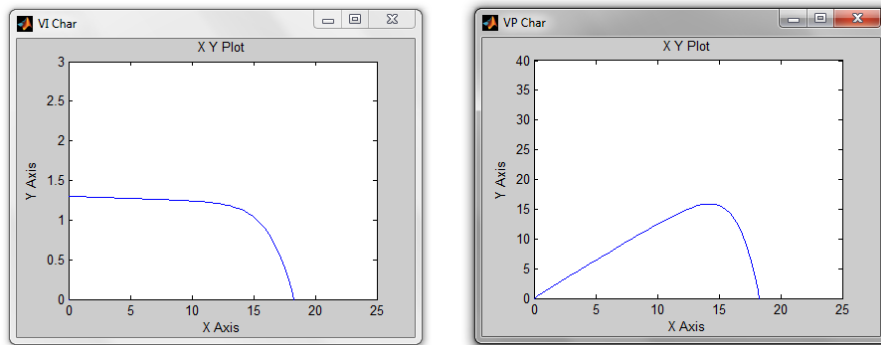
Fig. 3.10, 3.11, 3.12 and Table 3.1 summarize the results for different  $G$  with constant  $T$ .



**Fig. 3.10 Characteristics of Single PV Panel at  $G=1000 \text{ W/m}^2$  and  $T=40^\circ \text{ C}$**



**Fig. 3.11 Characteristics of Single PV Panel at  $G=800 \text{ W/m}^2$  and  $T=40^\circ \text{ C}$**

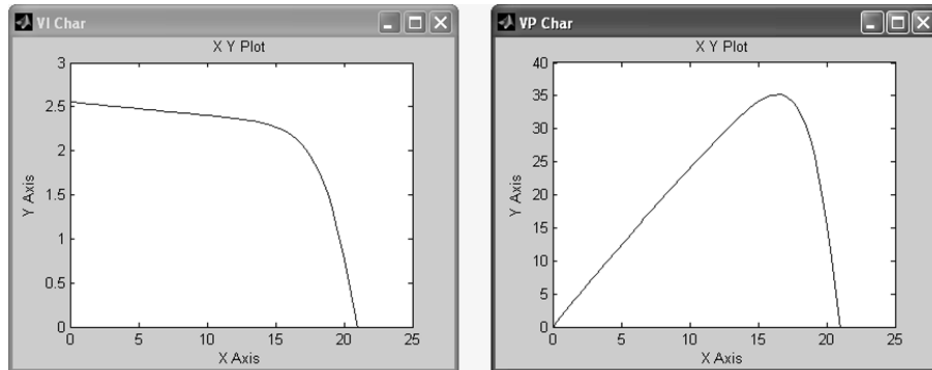


**Fig. 3.12 Characteristics of Single PV Panel at  $G=500 \text{ W/m}^2$  and  $T=40^\circ \text{ C}$**

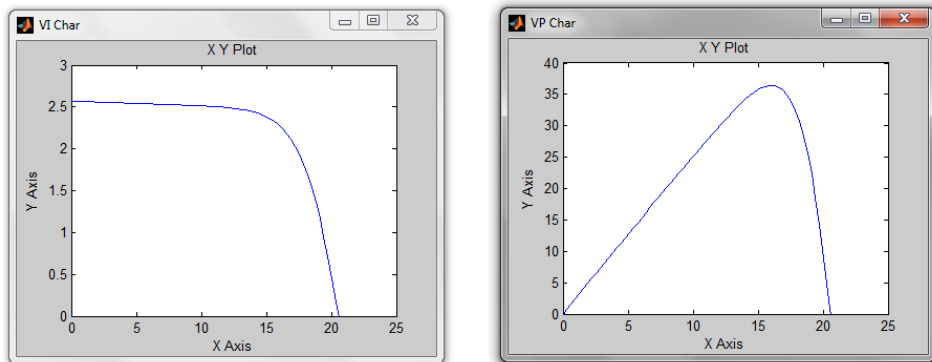
**Table 3.1 Power, Current and Voltage Measurement for Different Irradiation at Constant Temperature**

<b>G (W/m<sup>2</sup>)</b>	<b>T (° C)</b>	<b>V (V)</b>	<b>I (A)</b>	<b>P (W)</b>
1000	40	19	2.5	34
800	40	18.5	2.1	27
500	40	18	1.4	15

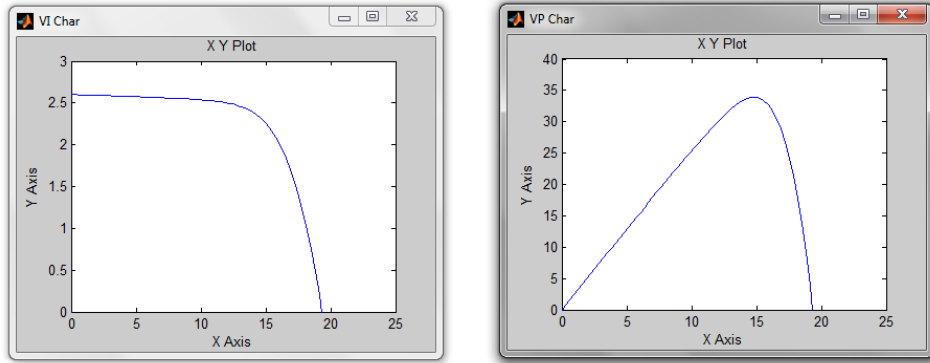
Fig. 3.13, 3.14, 3.15 and Table 3.2 summarize the results for different T with constant G



**Fig. 3.13 Characteristics of Single PV Panel at  $G=1000 \text{ W/m}^2$  and  $T=25^\circ \text{ C}$**



**Fig. 3.14 Characteristics of Single PV Panel at  $G=1000 \text{ W/m}^2$  and  $T=30^\circ \text{ C}$**



**Fig. 3.15 Characteristics of Single PV Panel at  $G=1000 \text{ W/m}^2$  and  $T=40^\circ \text{ C}$**

**Table 3.2 Power, Current and Voltage Measurement for Different Temperature at Constant Irradiation**

<b>G</b> <b>(<math>\text{W/m}^2</math>)</b>	<b>T</b> <b>(<math>^\circ \text{ C}</math>)</b>	<b>V</b> <b>(V)</b>	<b>I</b> <b>(A)</b>	<b>P</b> <b>(W)</b>
1000	25	21	2.51	34
1000	30	20.5	2.5	34
1000	40	19	2.5	33.5

From Table 3.1 and Table 3.2, it is observed that the peak power varies for change in both irradiation and temperature. Moreover, it is observed that the short circuit current decreased with respect to decrease in irradiation, where as open circuit voltage deviation is less with respect to change in irradiation. It is also observed that change in temperature affects the open circuit voltage point to a larger extent but has a lesser impact on the short circuit current.

Any change in irradiation and temperature causes change in peak point directly. To get the maximum available power at any time from the PV array, a proper MPPT system should be incorporated.

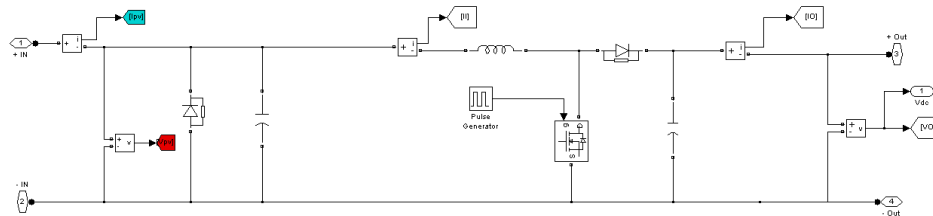
### **3.3 DESIGN AND SIMULATION OF DC-DC CONVERTER**

DC-DC converter converts DC of one magnitude to DC of another magnitude and is simply known as a DC converter. A DC converter can be deliberated as DC equivalent of an AC transformer with a turn ratio that is continuously

variable. The DC voltage can be stepped up or stepped down using this converter similar to a transformer. The principle of operation is available in literature. DC-DC converter can be classified in the following manner [Muhammad H. Rashid, 2004].

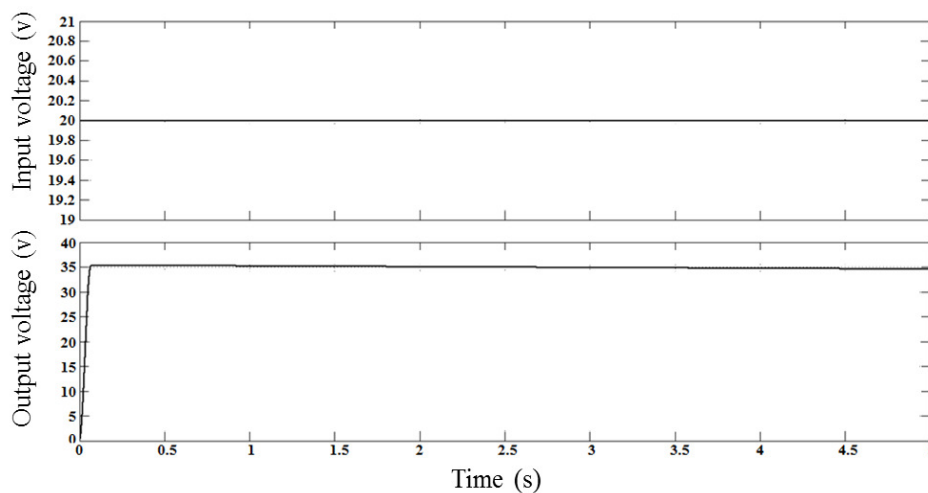
1. Buck converter
2. Boost converter
3. Buck-Boost converter
4. Cuk converter

Boost converter is utilized in this research work since the output of the SPV system should provide a constant DC output irrespective of the irradiation or temperature variations. The firing pulse is generated using the MPPT principle to maintain the output as a constant. Fig. 3.16 shows the simulation model of the DC-DC boost converter and Fig. 3.17 shows the result.



**Fig. 3.16 Simulink Model for DC-DC Boost Converter**

## Results



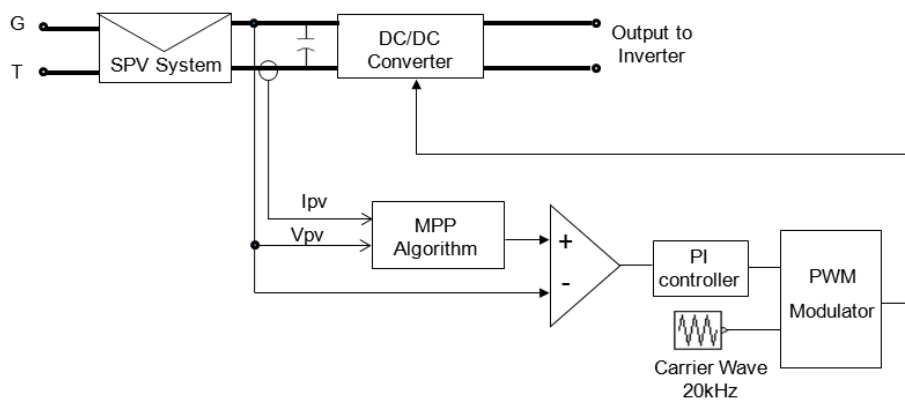
**Fig. 3.17 Input and Output Voltage of Boost Converter**



In this work the duty cycle of the DC-DC converter is controlled by pulse width modulation (PWM) as shown in Fig. 3.16. The MPP voltage at any instance is tracked by MPP algorithm and gives this MPP voltage as reference voltage for PWM modulator. This is compared with actual PV voltage and the error is minimized by continuously varying duty cycle of the DC-DC converter there by achieving the MPP.

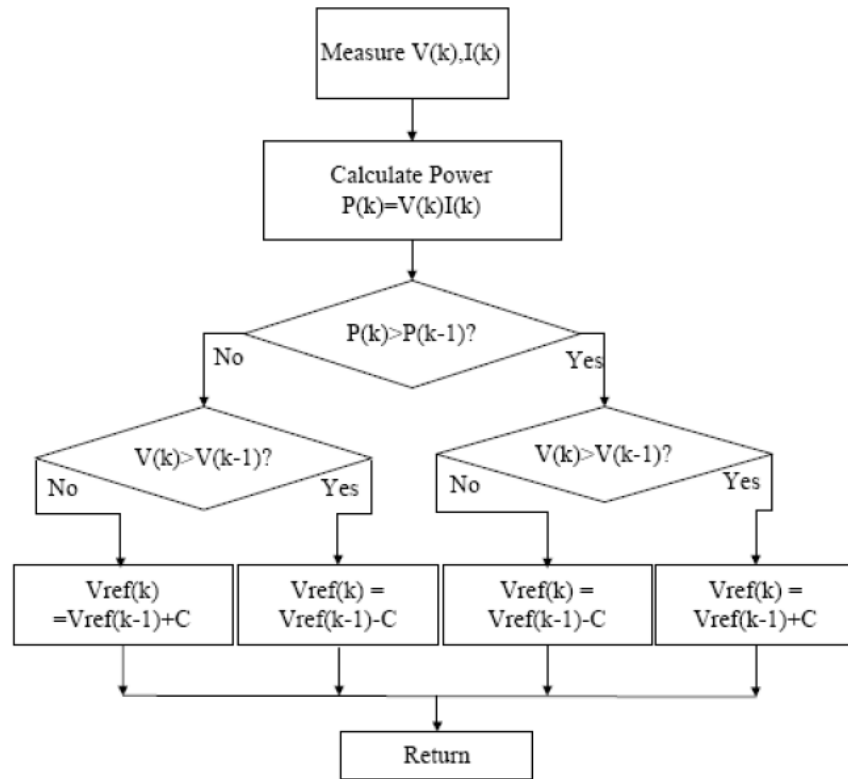
### 3.4 SIMULATION OF MAXIMUM POWER POINT TRACKING

The block diagram of the MPPT system is shown in Fig 3.18.



**Fig. 3.18 Block Diagram of the MPPT**

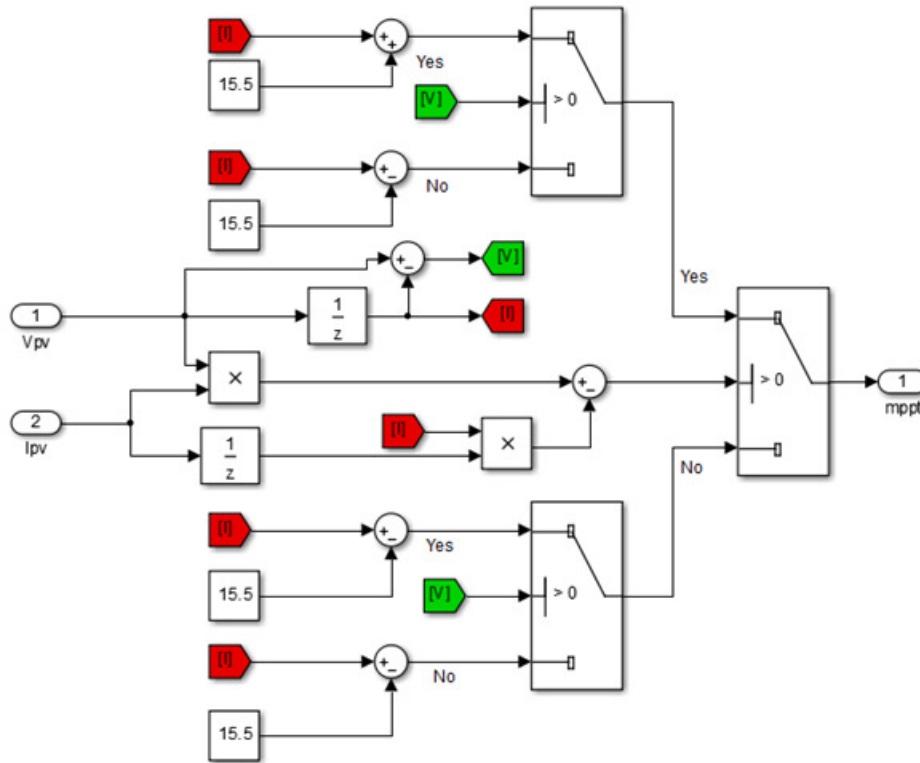
In this section the implementation of MPPT algorithm is described. There are number of MPP algorithms available in literature. The most popular and simple algorithms namely perturb and observe (P&O) and incremental conductance (INC) algorithms are used in this work. P&O algorithm is shown in Fig. 3.19.



**Fig. 3.19 Flowchart for P&O Algorithm**

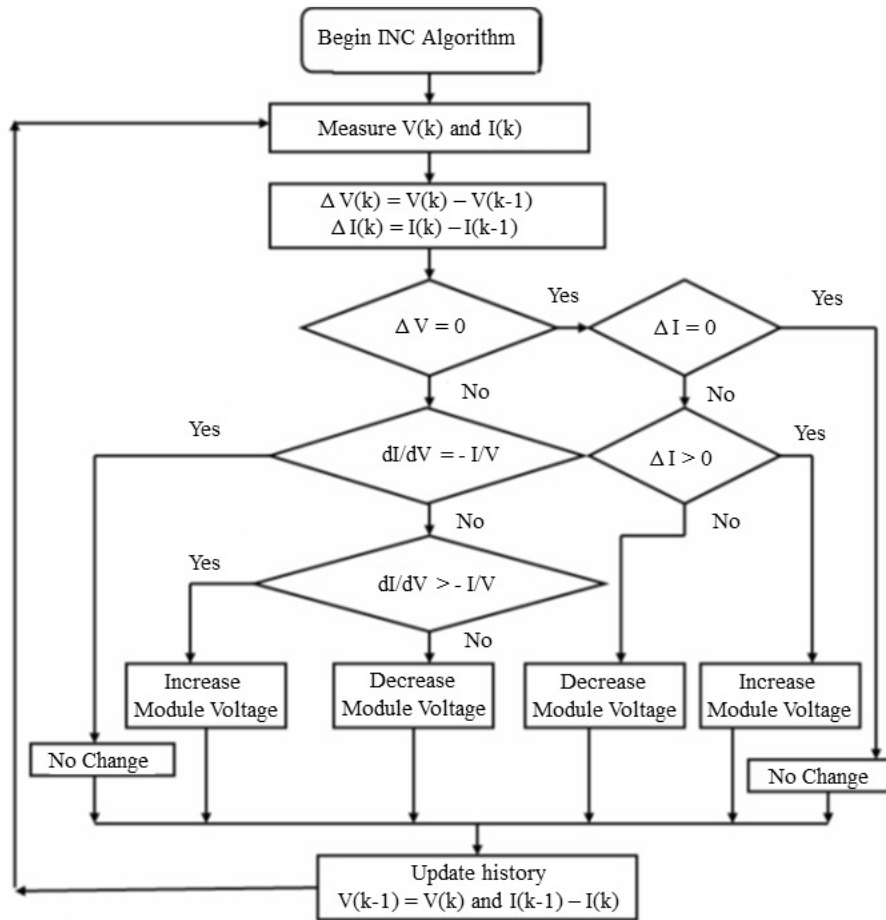
[David Sanz Morales, 2010]

MatLab implementation of P&O algorithm is shown in Fig. 3.20.



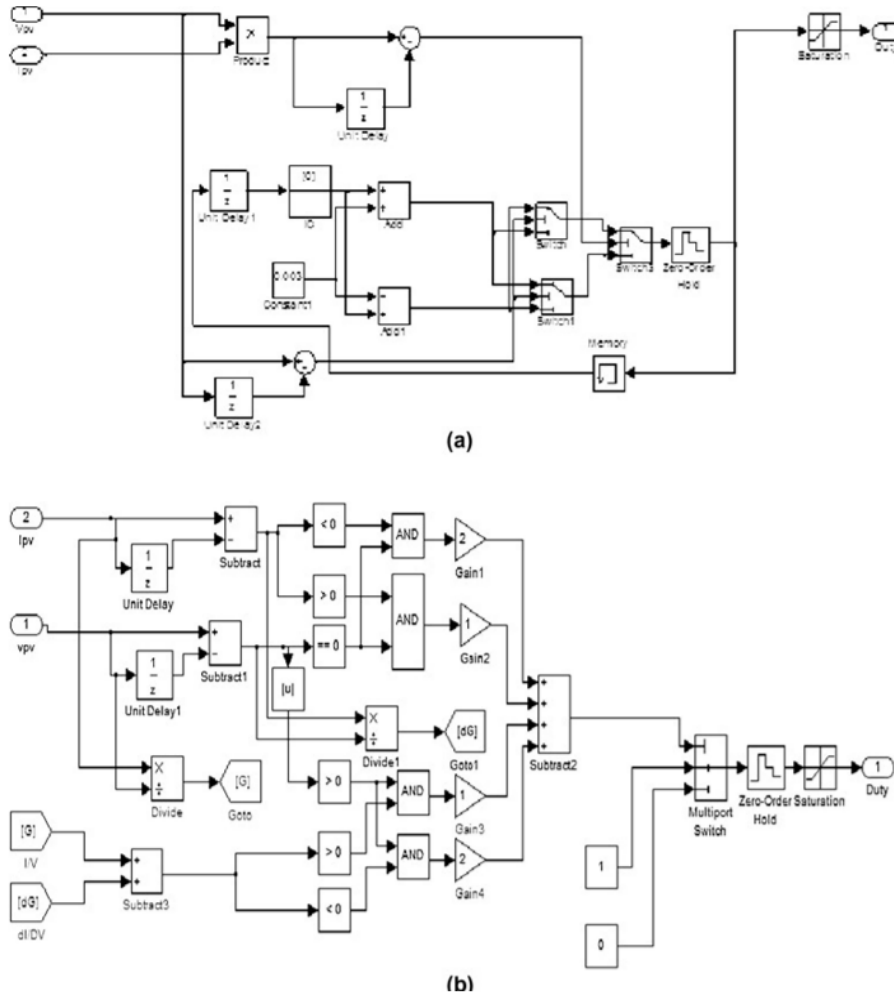
**Fig. 3.20 Simulink model of P&O Algorithm**  
 [Rosaidi Bin Roslan, 2009]

The flow chart for INC algorithm is shown in Fig. 3.21.



**Fig. 3.21 Flowchart for INC MPPT Algorithm**

MatLab implementation of INC algorithm is shown in Fig. 3.22.



**Fig. 3.22 Simulink model of INC algorithm**

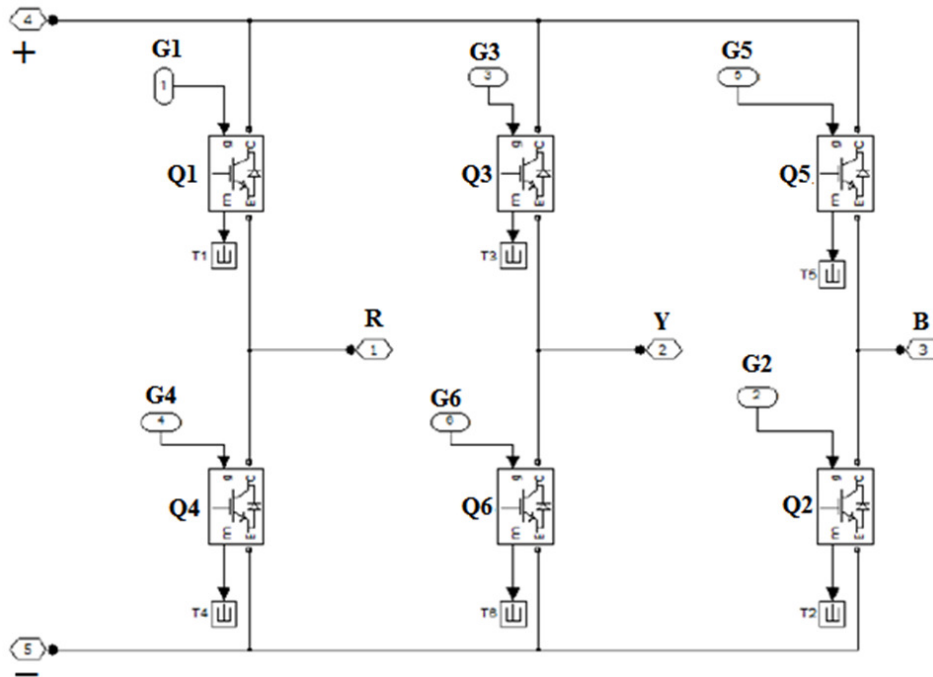
### 3.5 DESIGN AND SIMULATION OF PWM INVERTER

An inverter is a device that converts DC input voltage to a symmetrical AC output voltage of desired magnitude and frequency. The output voltage could be fixed or variable at a fixed or variable frequency. A variable output voltage can be obtained by varying the input DC voltage and maintaining the gain of the inverter as a constant.

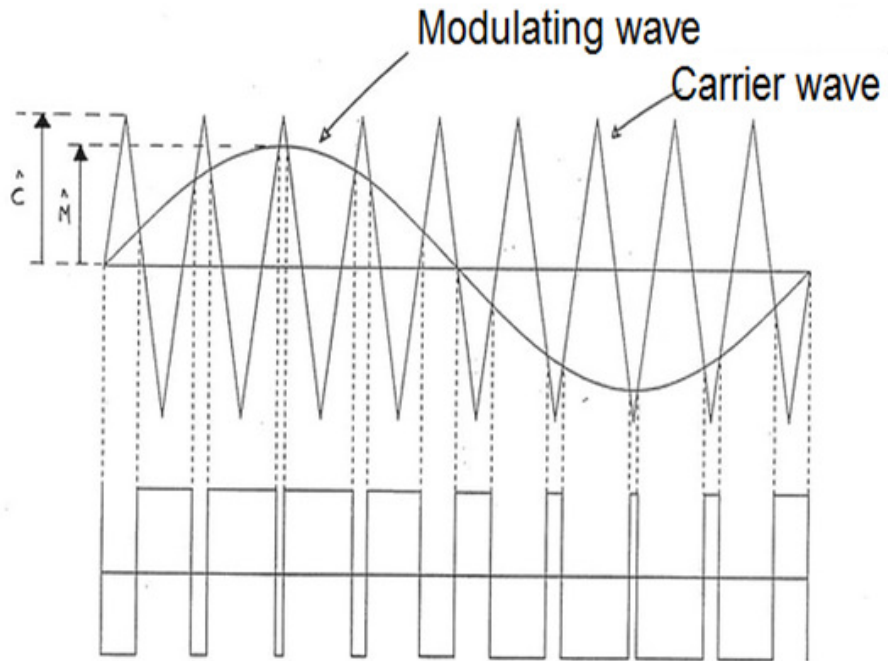
On the other hand, if the DC input voltage is fixed and it is not controllable, a variable output voltage can be obtained by varying the gain of the inverter, which is normally accomplished by PWM control within the inverter. The inverter gain may be defined as the ratio of the AC output voltage to DC input voltage.

A three-phase inverter is used in this research work to convert the DC output of the SPV system to symmetrical three phase AC supply of a particular magnitude, phase angle and frequency as determined from the grid to which the SPV is to be integrated.

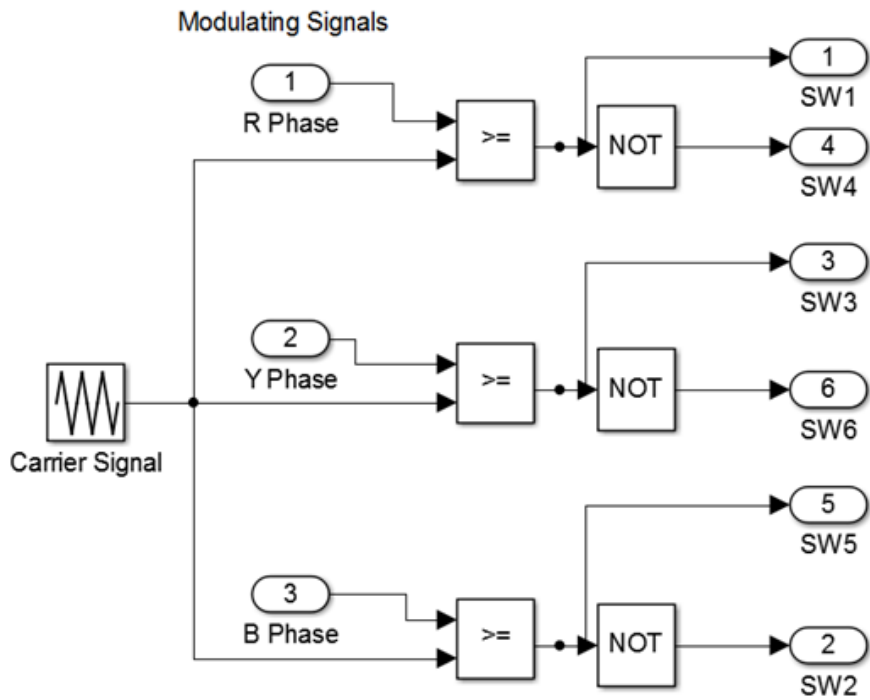
The principle of operation is available in literature [Muhammad H. Rashid, 2004]. Fig. 3.23 shows the simulation model of the three-phase inverter. Fig. 3.24 shows the inverter output.



**a. Simulink Model**



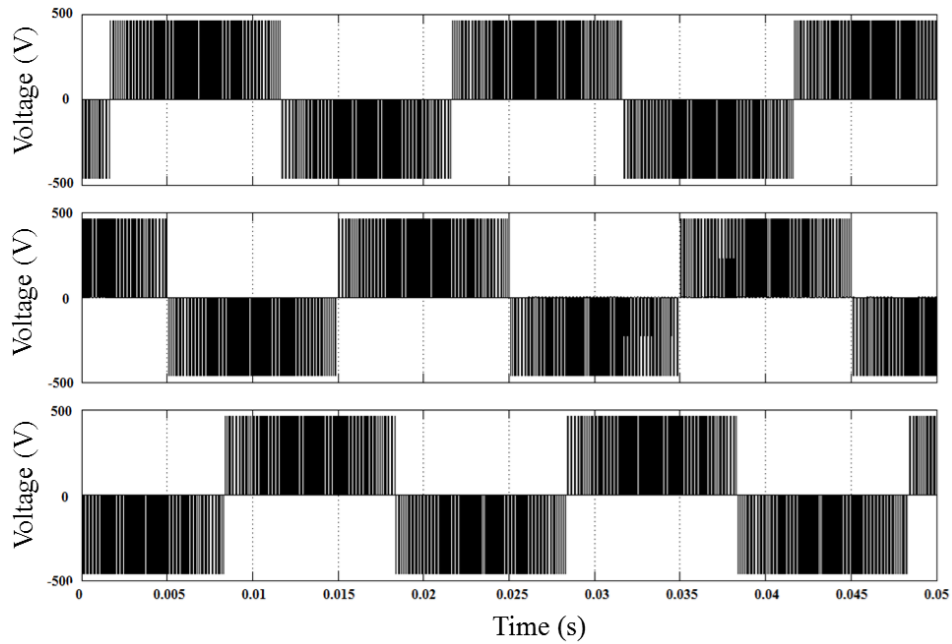
**b. Sin PWM Pulse Pattern**



**c. MatLab model for IGBT pulse**

**Fig. 3.23 Simulink Model for Three-Phase Inverter**

## Result



**Fig. 3.24 Inverter Output for a constant 250 V DC**

### 3.6 CONCLUSION

In this chapter the mathematical model of SPV system was modelled and the voltage, current and power characteristics were plotted. Analysis of these characteristics showed the SPV system relationship with irradiation and temperature which further led to the design of DC-DC converter with MPPT algorithm. P&O and INC MPPT algorithms were simulated and the DC converter was designed using these algorithms. To convert the DC to AC, a three phase inverter was designed and the voltage was recorded.



## CHAPTER 4

### DESIGN AND SIMULATION OF GRID CONNECTED PHOTOVOLTAIC SYSTEM

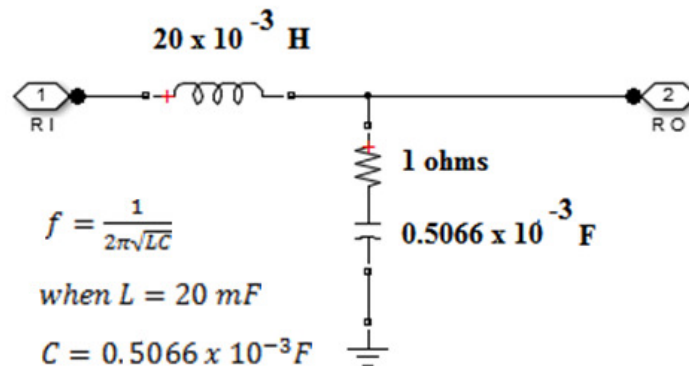
#### 4.1 INTRODUCTION

The step by step procedure for grid connection of SPV system is detailed in the coming section. A filter design for elimination of harmonics and a transformer to feed active power to the grid are taken up. Synchronization control technique high-lighting the drawback of existing methods and advantages of the proposed method is discussed.

#### 4.2 DESIGN OF FILTER AND GRID COUPLING TRANSFORMER

##### Filter

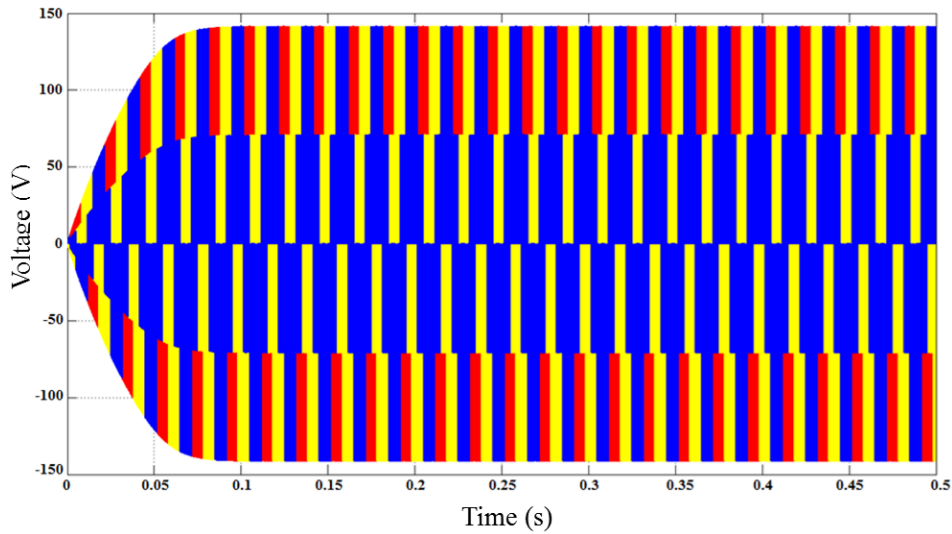
Filter is used to ground the unwanted harmonics and permit the signal of the required frequency to pass through it. Fig. 4.1 shows the simulation model of an AC filter designed for R phase. Similar circuit will be connected for Y and B phase to eliminate the harmonics of the three-phase inverter output.



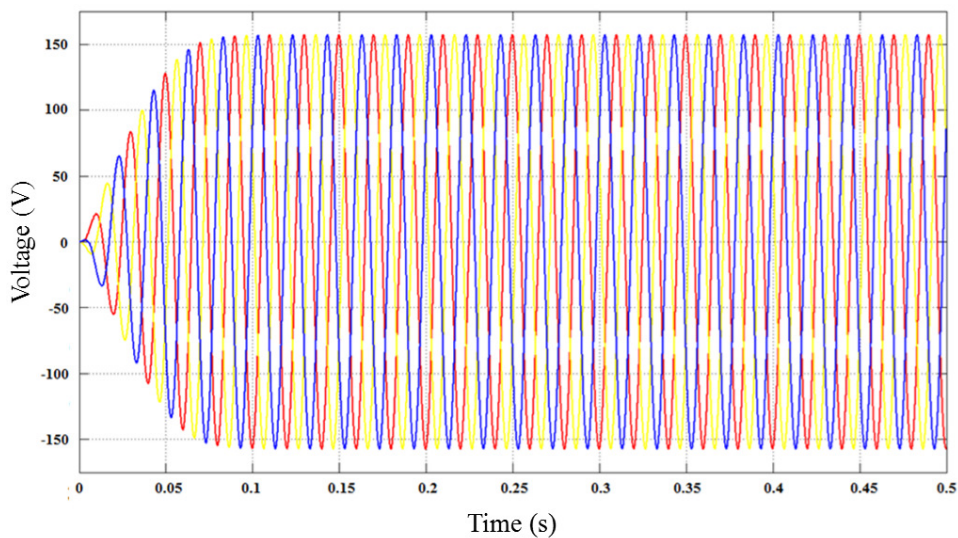
**Fig. 4.1 Simulink Model for Filter**

## Results

Fig. 4.2 and Fig. 4.3 show the inverter output before and after the filter respectively.



**Fig. 4.2 Wave Form before Filter**

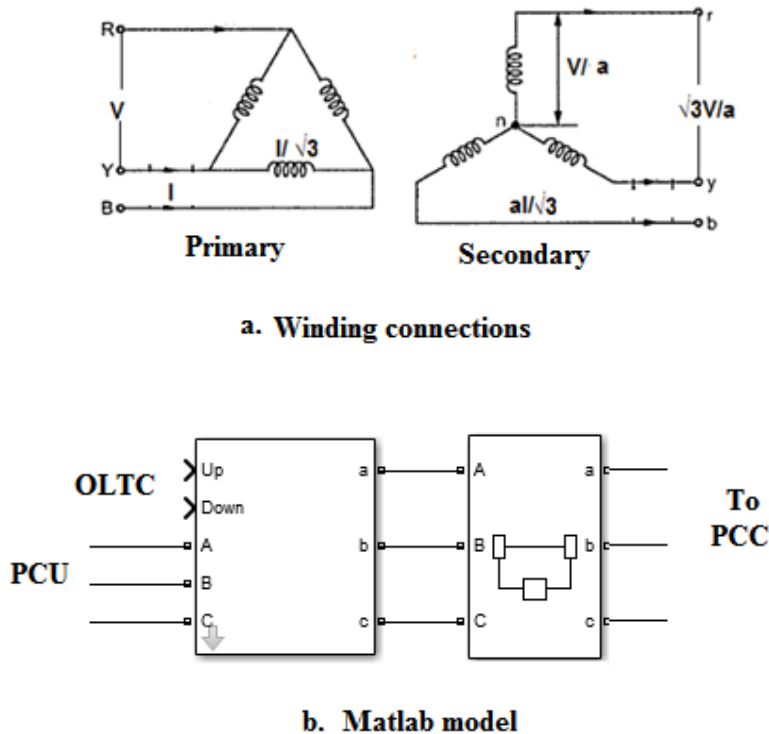


**Fig. 4.3 Wave Form after Filter**

## Grid coupling transformer

The grid coupling transformer is a step up transformer. Fig. 4.4 (a) shows the winding connections of the grid coupling transformer. The PCU is connected to the low voltage side of the transformer. The low voltage side is a delta

configuration to eliminate third harmonic in the grid thereby ensuring power quality delivered from the SPV system to the grid. The high voltage side is connected to the PCC through a circuit breaker which will be closed after synchronization check, detailed in the later part of this section. Fig. 4.4 (b) shows the MatLab model of the grid coupling transformer.



**Fig. 4.4 Grid Coupling Transformer**

The OLTC terminals receive a raise or lower pulse to raise or lower the voltage on the secondary side. To feed real power to the grid, the transformer secondary voltage should be slightly greater than the grid as per IEEE 929 standard. At the same time, higher magnitude difference oppose ANSI 25 standard of synchronization. The OLTC receives up or down pulses to satisfy both these conditions.

### **4.3 DESIGN OF GRID, LOAD AND SYNCHRONIZATION CHECK**

#### **Grid**

A grid is a network of synchronized power sources which can feed any amount of power. All the generation stations of a particular region combine to form a grid. The region refers to a city, state or even a county. In this work the grid is simulated by coupling five three phase generators in parallel, which are configured for similar voltage magnitude, frequency and phase angle. The grid shown in Fig. 4.5 (a) is a strong source which is capable of feeding the load connected to it without depending on the PCU which is connected in parallel to it. Each generator is connected through a three phase circuit breaker and can be operated to bring the generator in service. In this example, generator 1 and 2 are connected to the grid and the other generators are disconnected.

#### **Load**

In this work, loads are connected in parallel with separate circuit breakers such that they can be added or removed from the grid. Fig 4.5 (b) shows four loads connected in parallel, out of which two are in circuit with circuit breaker in closed position. Each load consists of resistive, inductive and capacitive components which facilitate the measurement of active and reactive power, thereby simulating a real time grid loading scenario.

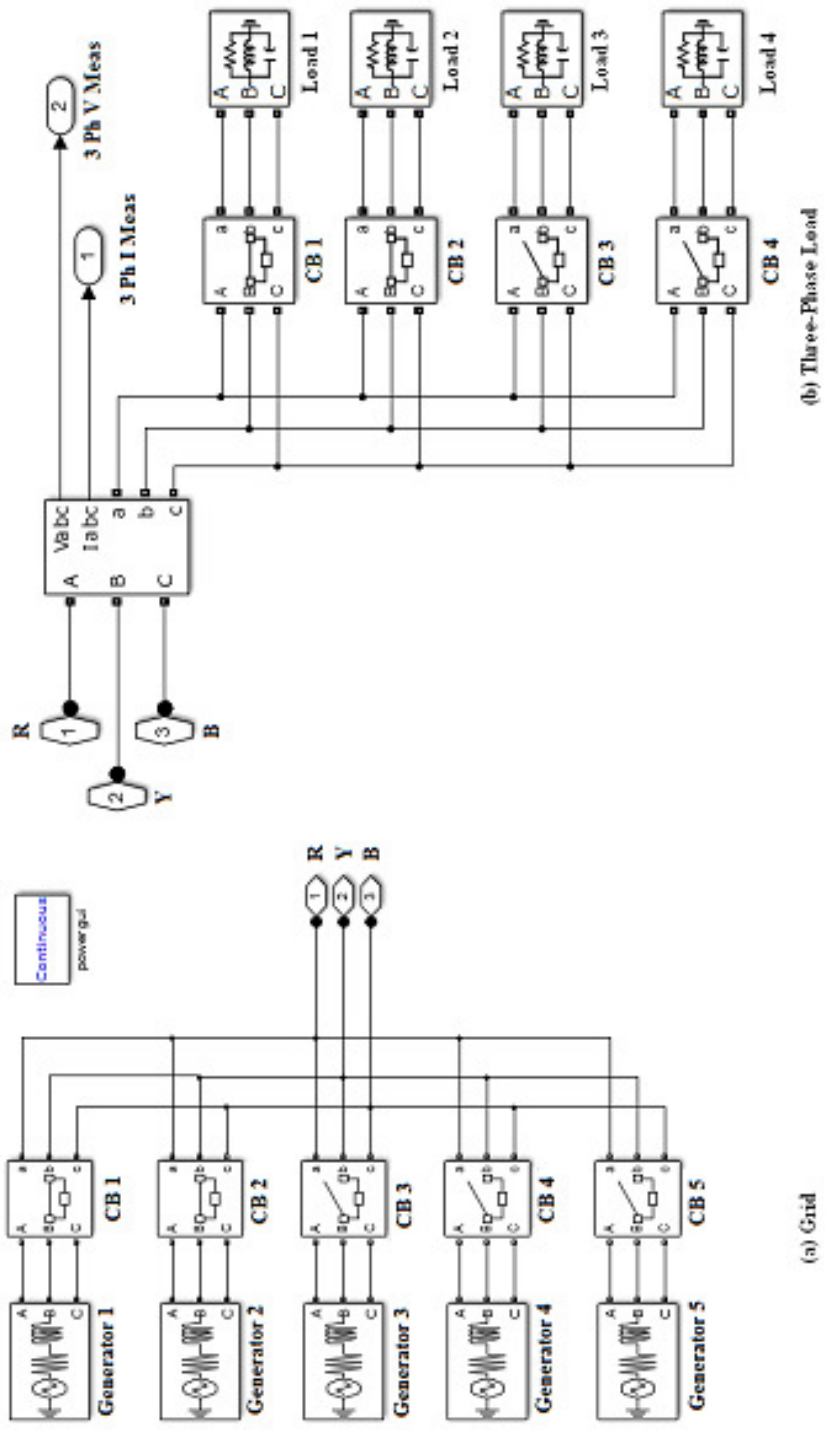


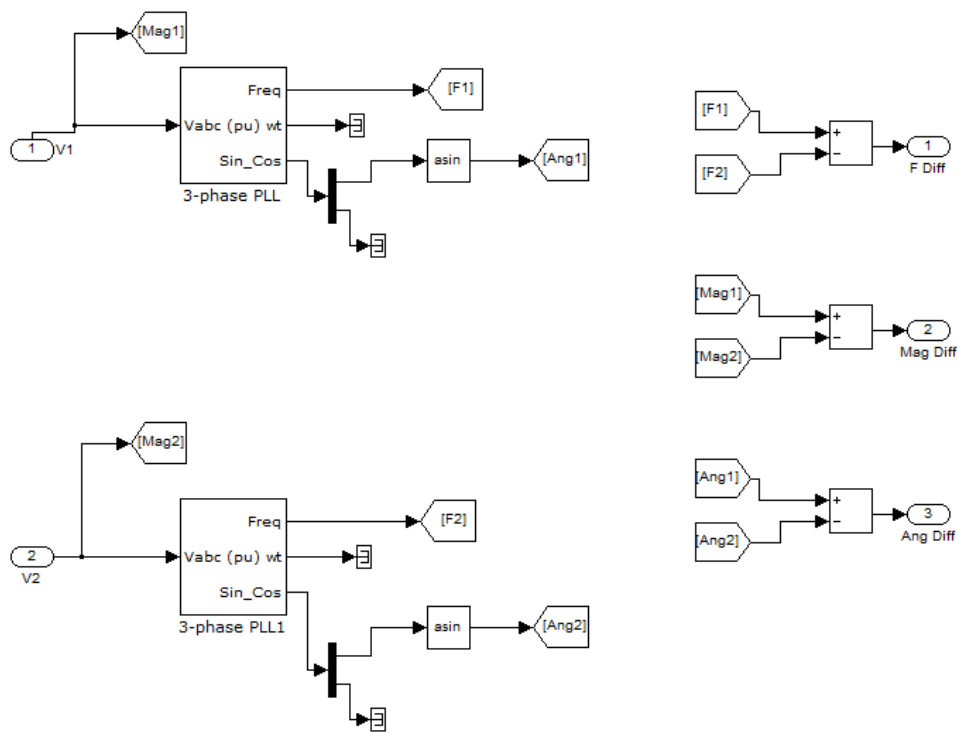
Fig 4.5 MatLab Models of Grid and Three-Phase Load

## Synchronization Check

In grid connected system the breaker close command will be issued only on verification of the synchronization condition. The synchronization condition checks the following three parameters,

1. Voltage
2. Frequency
3. Phase Angle

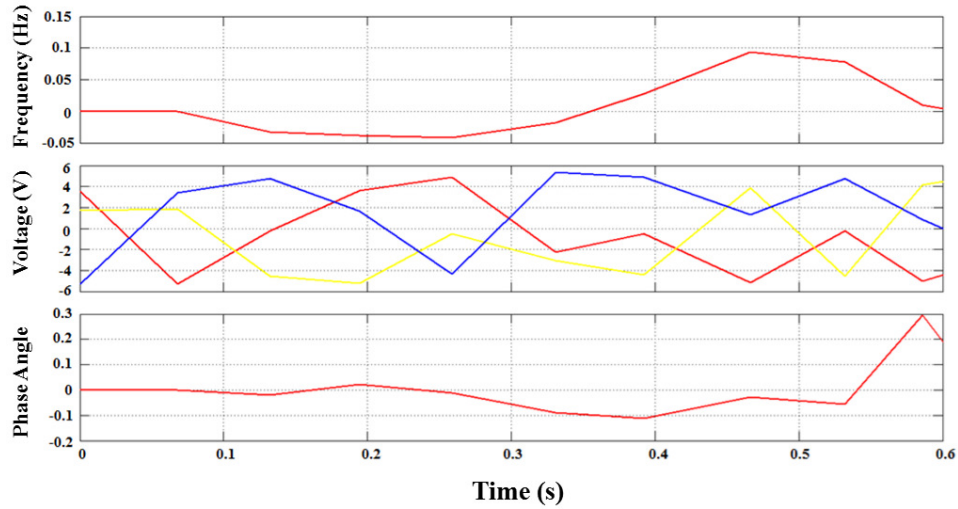
These three parameters are measured from the PCC and the output difference is measured for synchronization purpose. Fig. 4.6 shows the simulation model for a 'synchro check' used in the work.



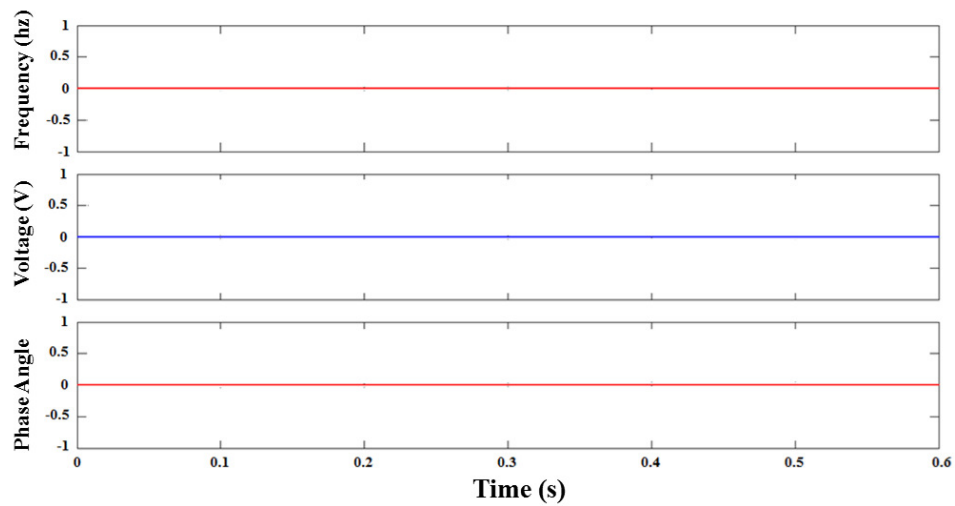
**Fig. 4.6 Simulation Model for Synchronization Check**

## Results

Fig 4.7 and Fig. 4.8 show the measurement of magnitude, frequency and phase angle difference between the PCU and PCC before and after the synchronization relay respectively.



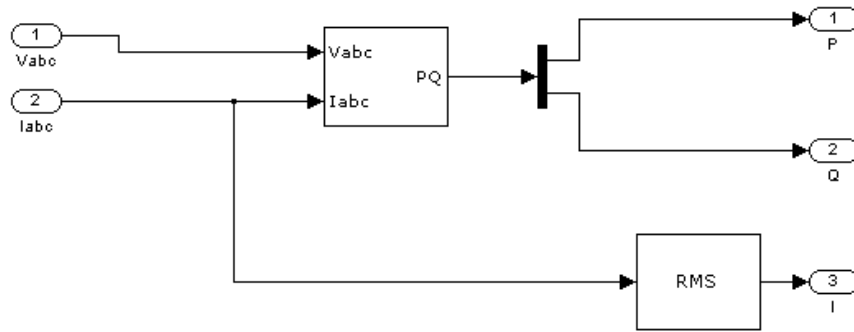
**Fig. 4.7 Frequency, Magnitude and Angle difference without Synchronization**



**Fig. 4.8 Frequency, Magnitude and Angle difference with Synchronization**

#### 4.4 MEASUREMENT OF GRID PARAMETERS

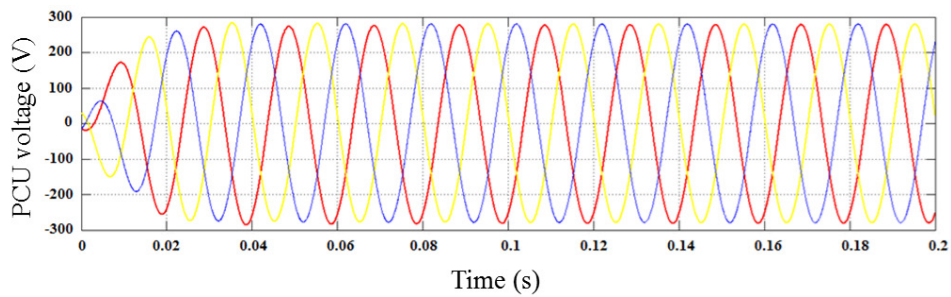
Active power, reactive power and current has to be measured in order to verify the power quality and for various other applications. Hence a measurement block is introduced to record these values. Fig. 4.9 shows the simulation model of the measurement block.



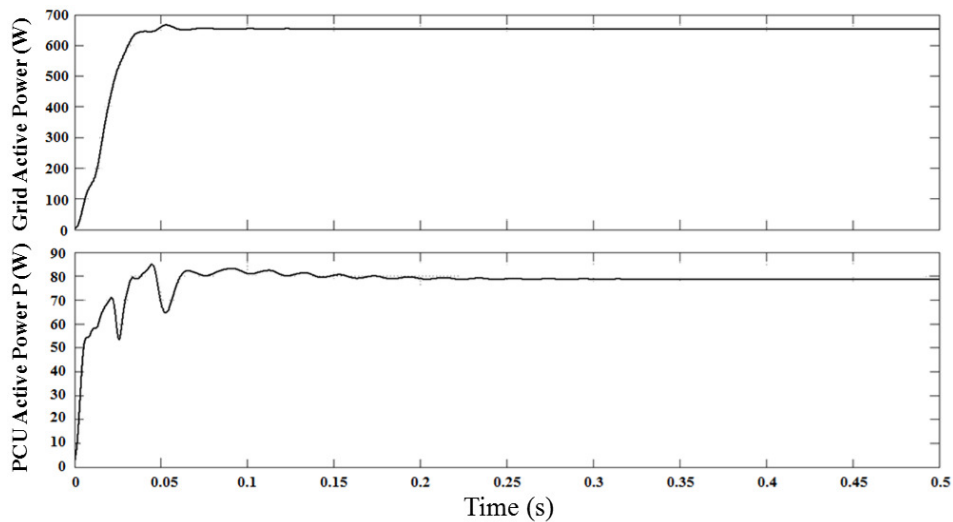
**Fig. 4.9 Simulink Model P and Q Measurement**

### Results

Fig. 4.10 shows the PCU voltage. Fig. 4.11 to Fig. 4.13 show the active power, reactive power and the current of PCU and grid.

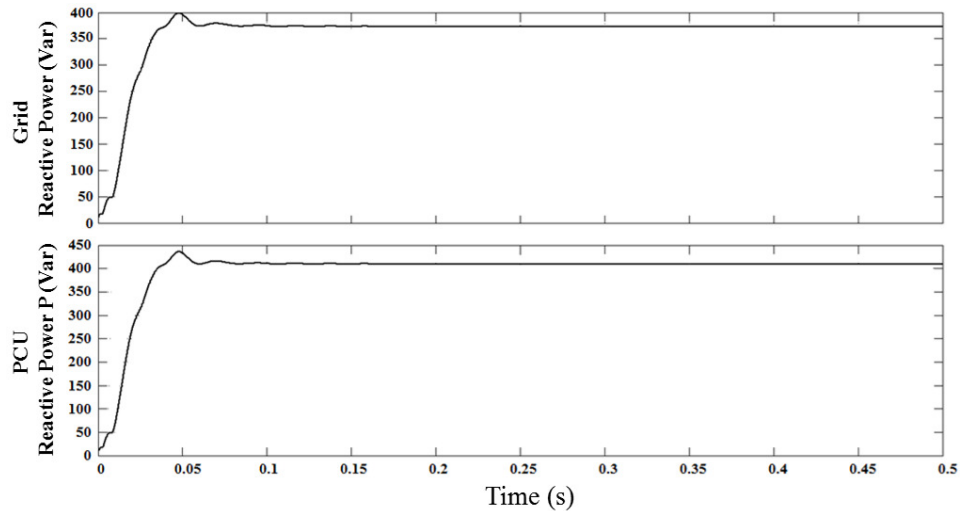


**Fig. 4.10 Solar Voltage Measurement**

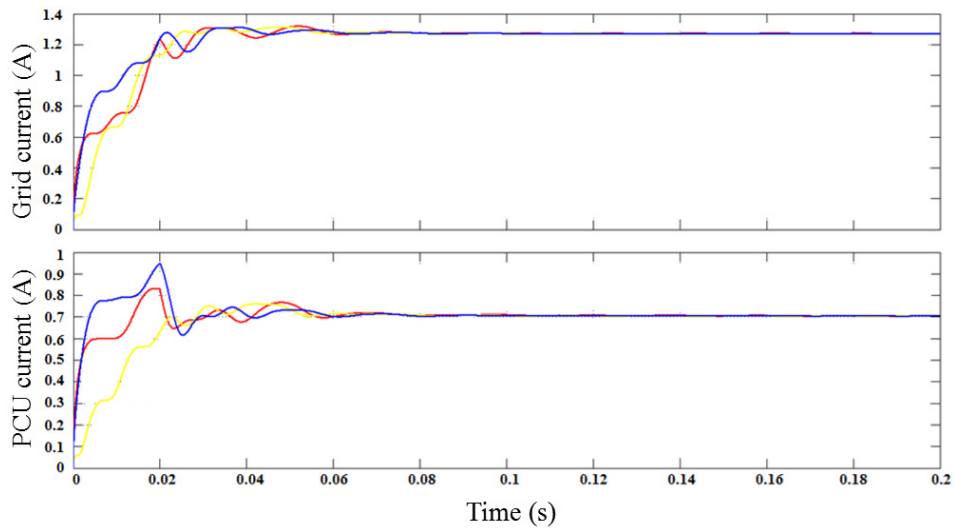


**Fig. 4.11 Grid and Solar Active Power Measurement**





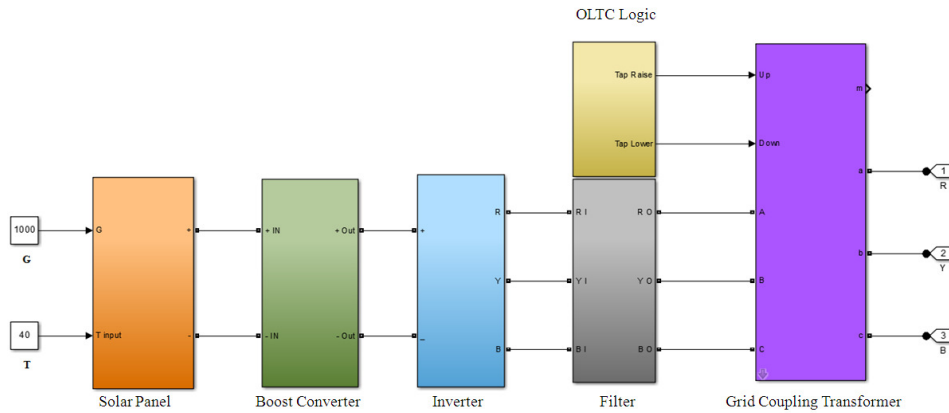
**Fig. 4.12 Grid and Solar Reactive Power Measurement**



**Fig. 4.13 Grid and Solar Three-Phase Current Measurement**

#### 4.5 SYSTEM INTERFACING

All the circuits described in this chapter are sub-divisions of the block shown in Fig. 4.14. A solar panel whose temperature and irradiation can be varied externally is connected to the boost converter where the MPPT circuit is implemented for generating the firing pulse. The MPPT output is connected to the inverter and the three-phase output is in turn connected to the filter. The filter eliminates the harmonics and the output is connected to the transformer for coupling to the grid.



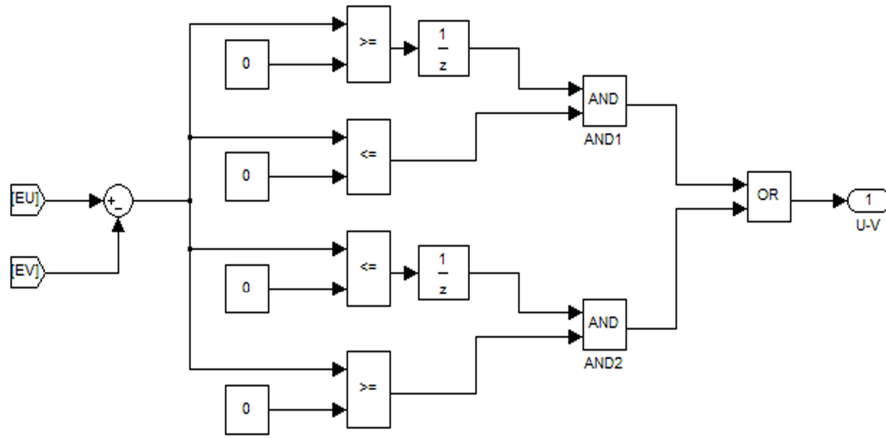
**Fig. 4.14 Simulink Model for Three-Phase Output from Solar Panel**

## 4.6 SYNCHRONIZATION TECHNIQUES

Inverter firing is based on the comparison of modulating and carrier signal. In case of grid connected system the output of the inverter is purely dependent on the grid parameters as the grid parameter is fed as the modulating signal. If the reference signal is affected by harmonics and unbalance due to grid disturbances, the inverter output is affected which results in poor power quality and further results in out of synchronization condition. To prevent such scenarios, suitable synchronization techniques are required which are discussed in this section.

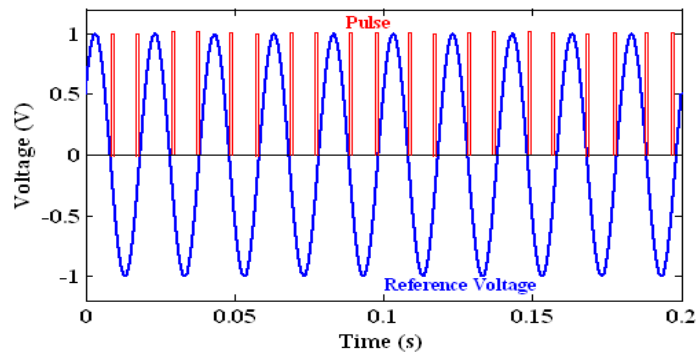
### 4.6.1 ZERO CROSSING DETECTION TECHNIQUE

The commonly used method of inverter firing is the zero crossing method in which a pulse is generated whenever the reference waveform crosses zero. The generated pulse is used for firing the inverter circuit. This method is modelled using MatLab as shown in Fig. 4.15.

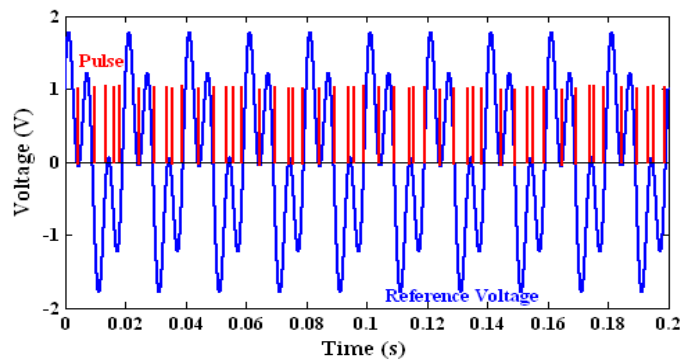


**Fig. 4.15 Zero Cross Simulink Model**

Based on the logic modelled in Fig. 4.15, it can be observed that a pulse is generated whenever the sine wave crosses zero as shown in Fig. 4.16. The pulse output of the ZCD method for a third harmonic wave is shown in Fig.4.17.



**Fig. 4.16 Zero Cross Pulse Output for 50 Hz Fundamental Frequency**



**Fig. 4.17 Zero Cross Pulse Output for 50 Hz Fundamental Frequency and 150 Hz Harmonic**

For harmonic rich grid current, one may expect irregular gating patterns. To illustrate this, the pulses generated for a third harmonic rich current spectrum is shown in Fig. 4.17. When this pulse is used for inverter firing, it would result in an unbalanced output resulting in an out of synchronization condition. Hence this method cannot be used for grid synchronisation under abnormal conditions which is likely to occur often.

#### **4.6.2 CHARGE PUMP PHASE LOCK LOOP TECHNIQUE**

Charge pump is a part of PLL which converts the phase or frequency difference to a voltage which is used to tune the voltage control oscillator. [Swanand Vishnu Solanke 2007-2009]. The application of CP-PLL control technique is used here to address the issues discussed in the previous section failing which the power quality and synchronization would be affected.

CP-PLL synchronization technique for grid connected SPV system is illustrated in Fig. 4.18. The operation principle of PLL is shown in Fig.4.19 (a). Phase difference is the pulse produced when there is a phase angle difference between the input voltage and the voltage controlled oscillator output voltage. The pulse width is directly proportional to the amount of difference. The phase difference pulse width appears as a spike when the voltage controlled oscillator is in phase with the reference voltage. If the voltage controlled oscillator is used as the modulating signal, then the inverter pulse firing pattern is adjusted based on the grid reference eliminating sudden change in the reference signal due to grid disturbance [David Sanz Morales, 2010].

The MatLab model of this circuit is shown in Fig. 4.19 (b). The PWM depends on the modulating signal quality. The PCC voltage is taken as reference and the PWM pulses are generated based on modulating signal using CP-PLL technique. A balanced three phase symmetrical voltage is assumed in CP-PLL design technique [Muhammad H. Rashid, 2004].

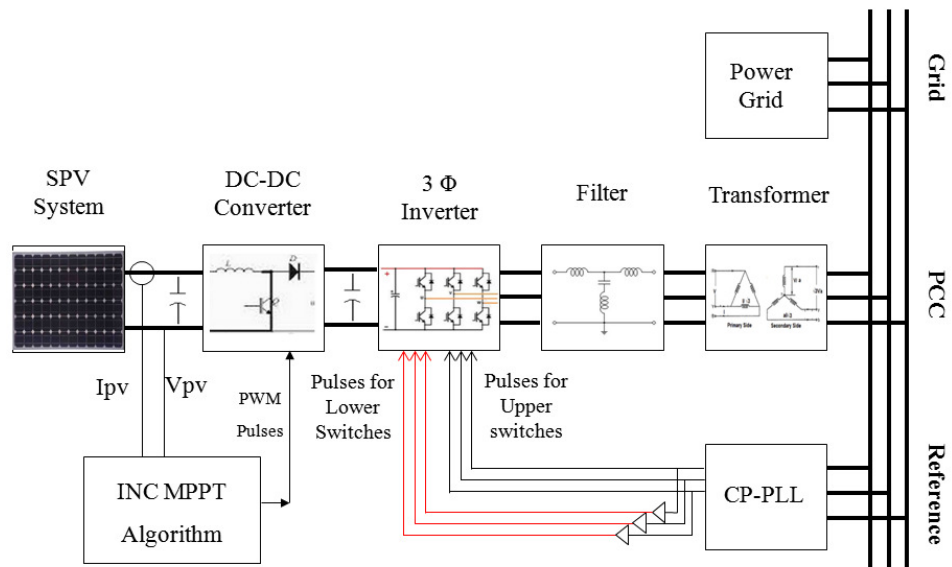


Fig. 4.18 Schematic Representation of the System

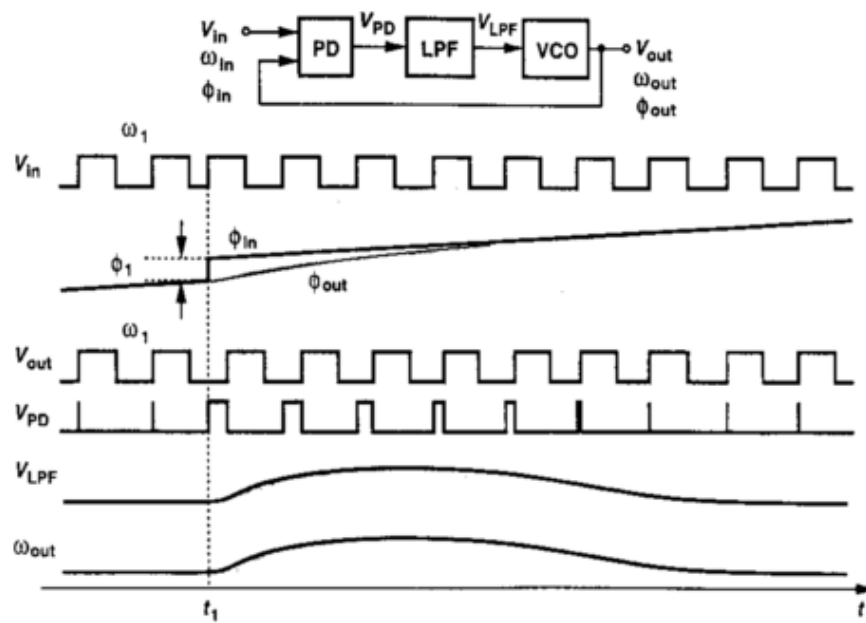
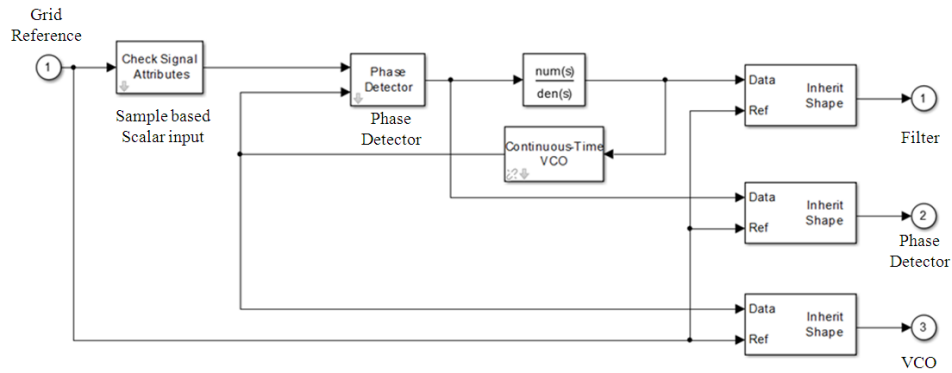


Fig. 4.19(a) Basic Operation of PLL



**Fig. 4.19(b) MatLab Implementation of CP-PLL**

The simulation parameters of the system design and sizing are listed in Table 4.1. MatLab simulink model of CP-PLL method is shown in Fig. 4.20.

**Table 4.1 Simulation Parameters for the Proposed System**

Parameters	Values
Grid voltage	415 V
Single PV panel voltage	16.54 V
Single PV panel current	2.25 A
No. of cells in single PV panel	36 in series
PV Array size	14 x 2 (14 panels in series and 2 panels in parallel)
PV array voltage	230 V
PV array current	4.5 A

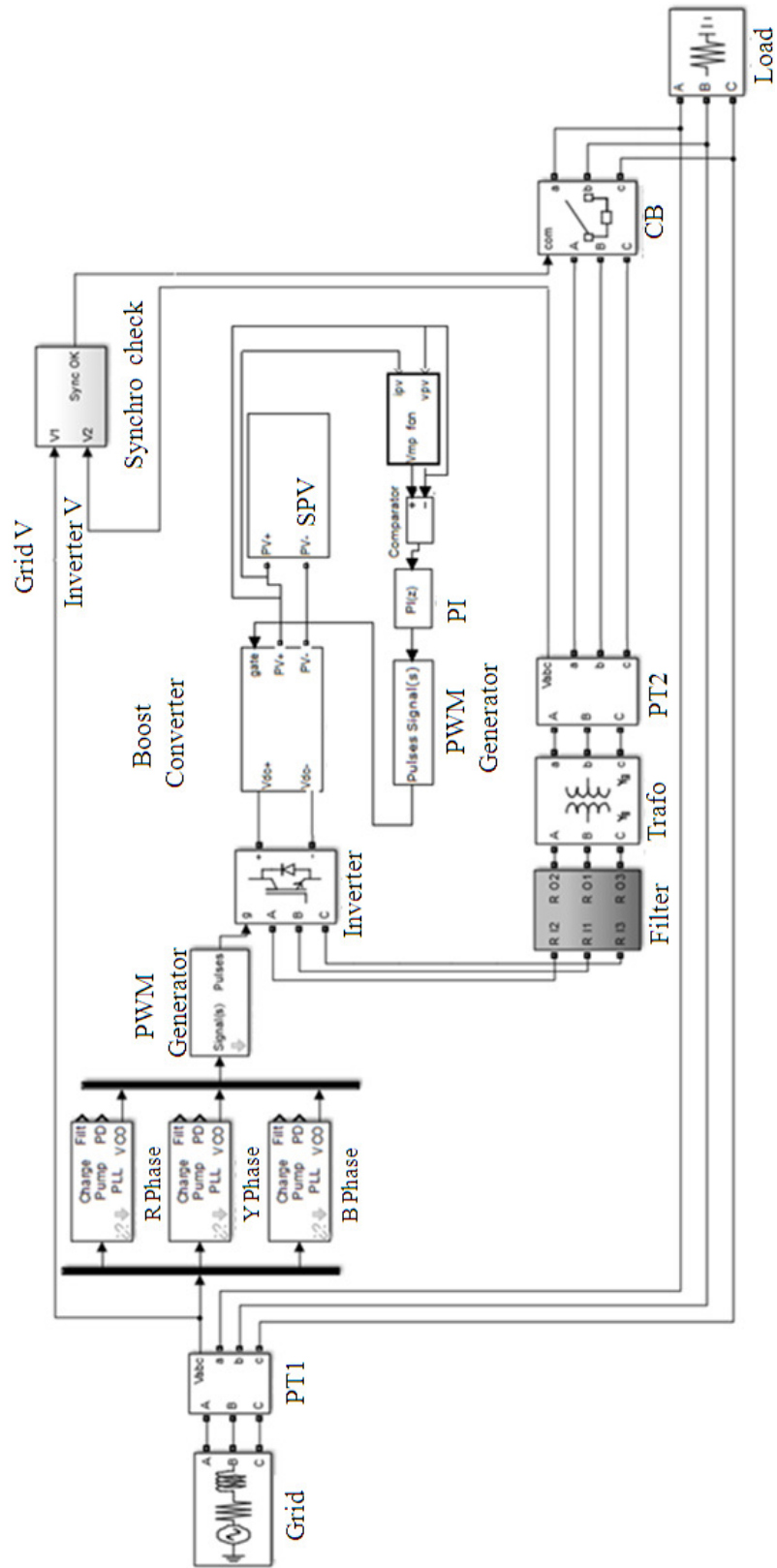
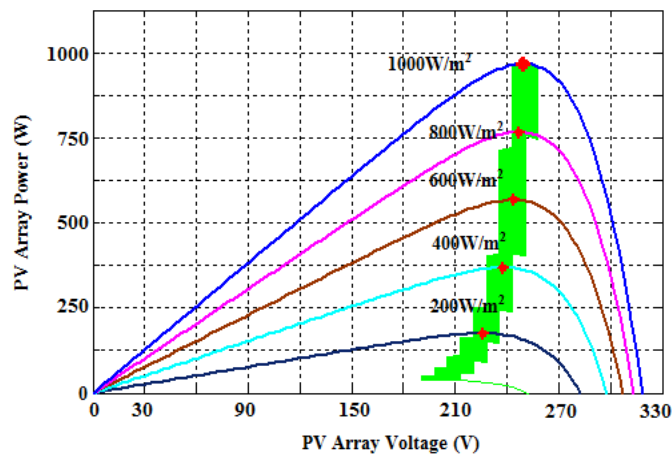


Fig. 4.20 MatLab-Simulink Model of the System shown in Fig. 4.18

MPPT algorithm is used to track the maximum power point voltage. For CP-PLL technique, INC MPP algorithm is used by considering its simplicity and ability to track global MPP [Rosaidi Bin Roslan, 2009]. The flowchart for INC MPP algorithm is displayed in Fig. 3.21 in Chapter 3. The algorithm is coded in MatLab embedded function tool and interfaced with the converter. The simulated results for INC MPP algorithm is shown in Fig. 4.21. It is observed that the MPP algorithm always tracks the MPP voltage which is around the required 230V for all insolation levels. Here, boost converter is used as MPP tracker and is designed for continuous conduction mode (CCM) of operation using the equations given in literature [David Sanz Morales, 2010]. The output from MPP tracker is fed to the inverter via DC-DC converter. The output of the inverter is then connected to a transformer through a proper filter.



**Fig. 4.21 Tracking Characteristics of INC MPPT Algorithm**

The PCU voltage should be greater than the system voltage in order to supply active power as specified in IEEE 929 and hence a transformer with OLTC mechanism is accommodated. The standards for grid connected SPV system is summarized in Table 4.2. To verify the synchronization condition a relay complied with ANSI 25 is used.

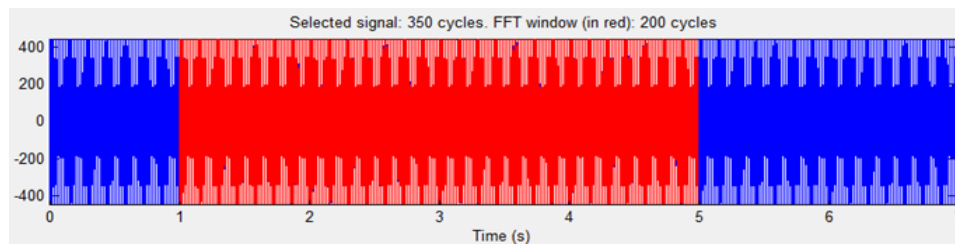


**Table 4.2 Synchronization Standards for SPV Inverter Fed Grid Systems**

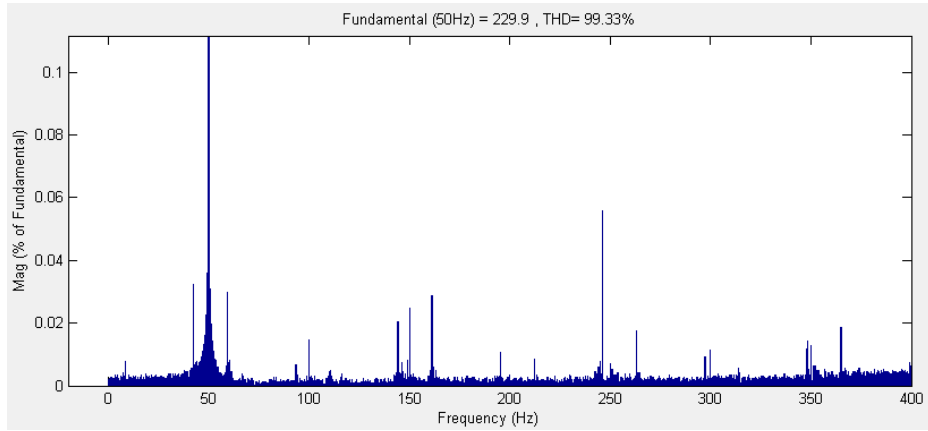
Parameters	Standards
Voltage Magnitude	IEEE 929
Frequency	IEEE 929
Phase Angle	IEEE 929
Synchronization	ANSI 25
Voltage Protection	ANSI C84.1
Current Harmonics	IEC 61727 / IEEE 1547

**Response of the System for Grid Disturbances**

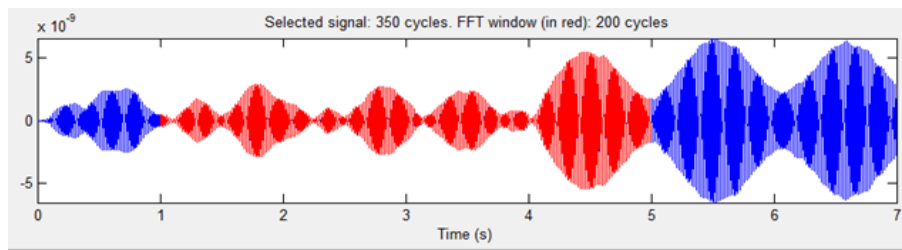
The most common scenarios in power system during a disturbance have been simulated and the response of CP-PLL is recorded and verified in this section. Response of the system during the presence of harmonics is also tested with fast fourier transformation (FFT) tool at every stage. Harmonic distortion of more than 1000 % in the voltage was introduced at the PCC in the system shown in Fig.4.22. Total harmonic distortion (THD) was observed to be extremely high and is displayed as infinity. Further to identify the harmonic suppression capability of this technique, the harmonics at the PCC was reduced considerably to 99.33 % (with only 2<sup>nd</sup>, 3<sup>rd</sup> and 4<sup>th</sup> order harmonics) (Fig. 4.23). The harmonics of the output spectrum had a THD of 82.32 % (Fig. 4.25). The results do not comply with IEC 61727 and IEEE 1547 standard (Fig. 4.22 to Fig. 4.25) as the tolerance limit as per standard is 5 % THD.



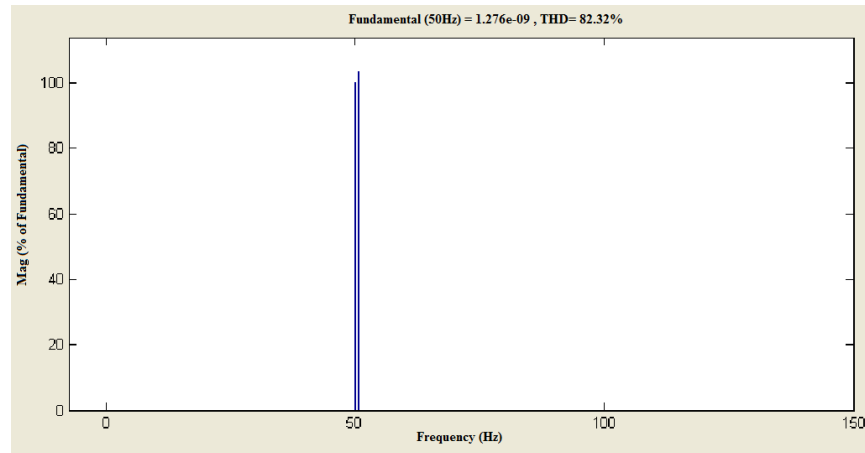
**Fig. 4.22 Voltage Spectrum at PCC**



**Fig. 4.23 THD of Voltage at PCC**



**Fig. 4.24 Current Spectrum at PCU in CP-PLL Technique**

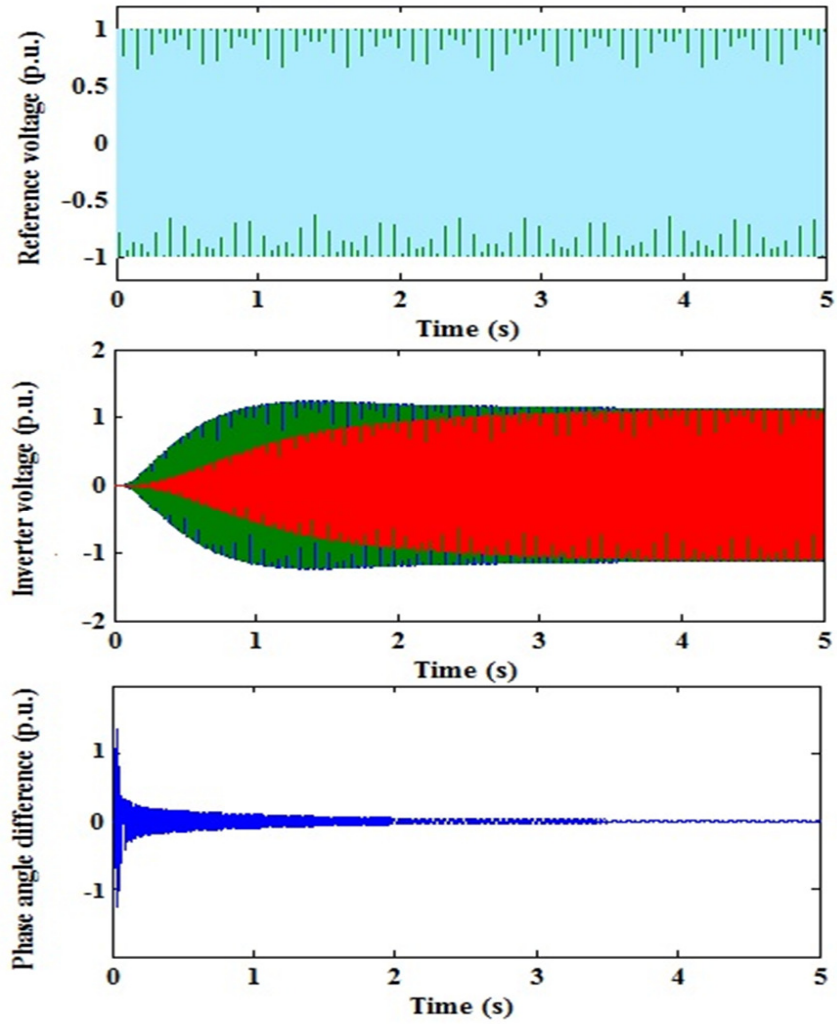


**Fig. 4.25 THD Measured at PCU in CP-PLL Technique**

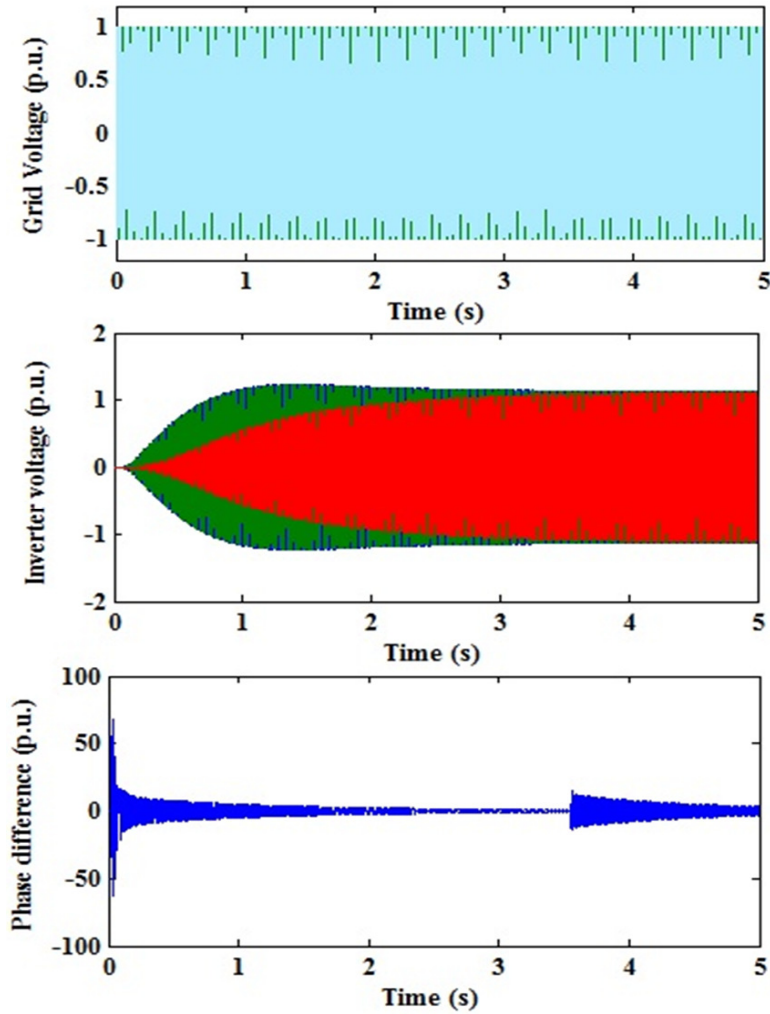
**Table 4.3 Current Harmonics Distortion of CP-PLL Method  
for Different Cases**

<b>Different cases under study</b>	<b>Injected harmonics (%)</b>	<b>Permissible limit as per IEC 61727 / IEEE 1547 Standards is &lt; 5 %</b>
		<b>% THD from CP-PLL</b>
Practical	5	81.33
Measurable	99.33	82.32
Worst Case	1065.4	Extremely High

Fig. 4.26 shows the output voltage spectrum of PCU and PCC. The difference between these two voltages is adjusted by the CP-PLL till the PCU is in phase with the PCC. This can be observed when the PD becomes almost zero after a moment. A sudden variation in frequency is made at PCC to verify the response of CP-PLL and it was found that the PCU is following the PCC after the disturbance. Fig. 4.27 shows how the phase difference has increased during the disturbance and then gets settled within a short duration. This is complied with IEEE 929 standard where the difference in phase is permitted before a grid islanding.



**Fig. 4.26 CP-PLL Output displaying the Suppression of Phase Difference between Grid and Inverter Voltage under Normal Frequency Conditions**



**Fig. 4.27 CP-PLL Output Displaying the Suppression of Phase Difference between Grid and Inverter Voltage under Disturbance Conditions**

### 4.6.3 SYNCHRONIZED REFERENCE FRAME PHASE LOCKED LOOP TECHNIQUE

Magnitude of grid current and the sine and cosine angle of the grid voltage is taken as reference and transformed to  $dq0$  frame [Matues and Denizar, 2008].

The equation for this transformation is shown below.

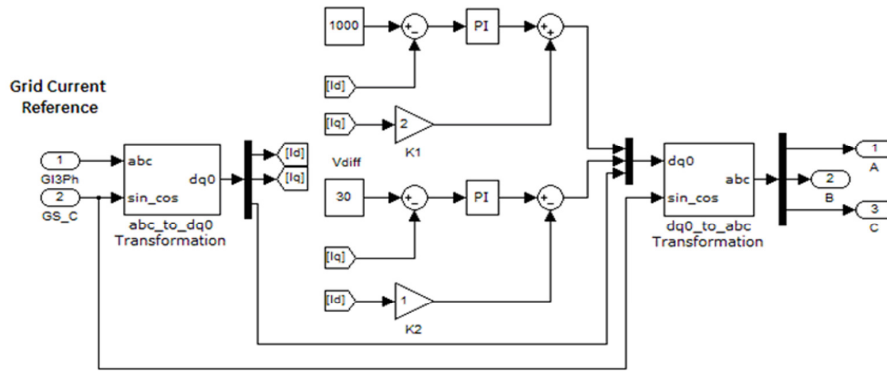
$$I_d = \frac{2}{3} [I_a \sin(\omega t) + I_b \sin(\omega t - \frac{2\pi}{3}) + I_c \sin(\omega t + \frac{2\pi}{3})] \quad (4.1)$$

$$I_q = \frac{2}{3} [I_a \cos(\omega t) + I_b \cos(\omega t - \frac{2\pi}{3}) + I_c \cos(\omega t + \frac{2\pi}{3})] \quad (4.2)$$

$$I_o = \frac{1}{3} (I_a + I_b + I_c) \quad (4.3)$$

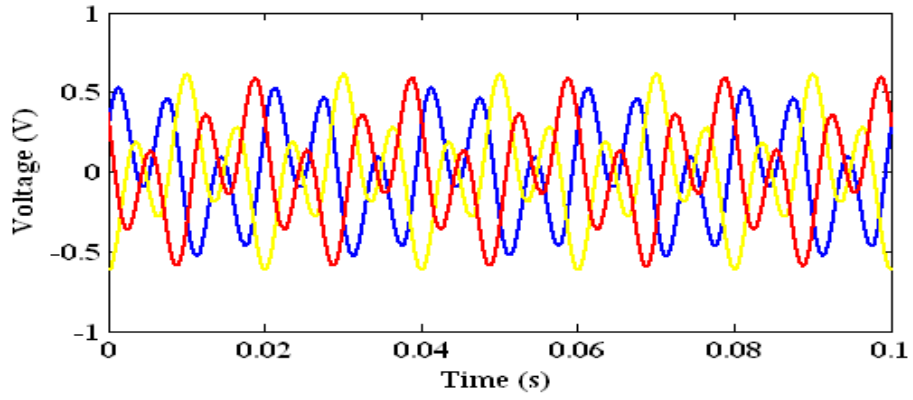
Where,  $\omega$  = angular velocity of the rotating frame

The simulink model of the SRF-PLL is shown in Fig. 4.28.  $I_d$  and  $I_q$  values are compared with the DC reference and a PI controller is used.

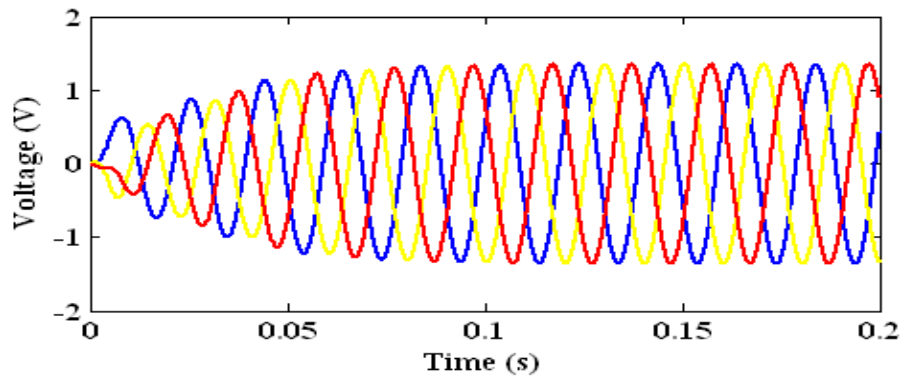


**Fig. 4.28 Simulink Model of SRF-PLL**

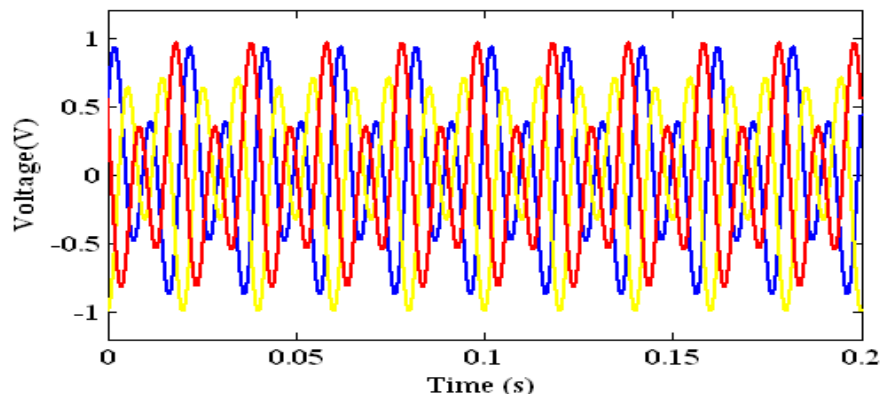
The output is transformed to *abc* reference and it is used as the modulating signal for the inverter pulse firing circuit. To test the effectiveness of SRF-PLL, a harmonic rich input as shown in Fig. 4.23 is applied. Fig. 4.29 shows the harmonic rich input spectrum of SRF-PLL technique. It is observed that for input frequencies other than 100 Hz, the output of the SRF-PLL is balanced and settled as shown in Fig. 4.30. The output of the SRF-PLL is found to be unbalanced when the input voltage spectrum has 100 Hz harmonics as shown in Fig. 4.31 and Fig. 4.32. To improve the output quality and to eliminate second harmonic, two types of digital filters namely low pass filter (LPF) and moving average filter (MAF) are introduced.



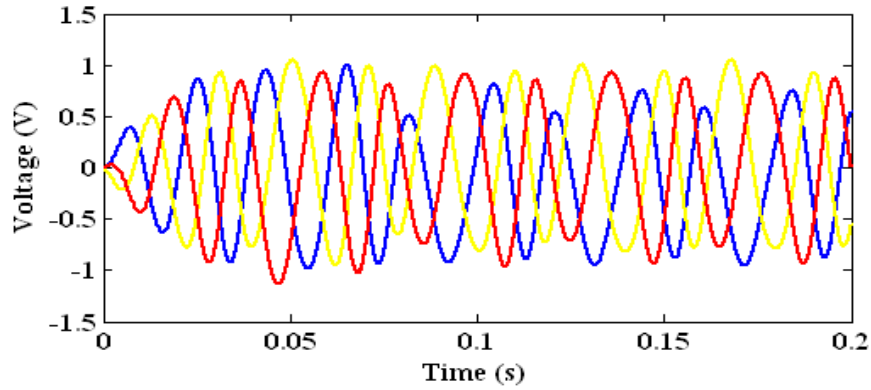
**Fig. 4.29 Harmonic Rich Input Voltage Spectrum for SRF-PLL**



**Fig. 4.30 Output Voltage Spectrum for SRF-PLL**



**Fig. 4.31 Second Harmonic Input Voltage Spectrum for SRF-PLL**



**Fig. 4.32 Output of SRF-PLL Method for 100 Hz (2<sup>nd</sup> Harmonic)**

#### **4.6.3.1 DESIGN OF LOW PASS FILTER**

A low pass filter is designed to eliminate the issues of second harmonic component. The simulink model of the SRF-PLL method with LPF is shown in Fig. 4.33. LPF is introduced in the inverter section and design [Barbosa et al, 2006] is explained below.

The first order low pass filter is given below

$$\frac{1}{1 + \frac{S}{a}} \quad (4.4)$$

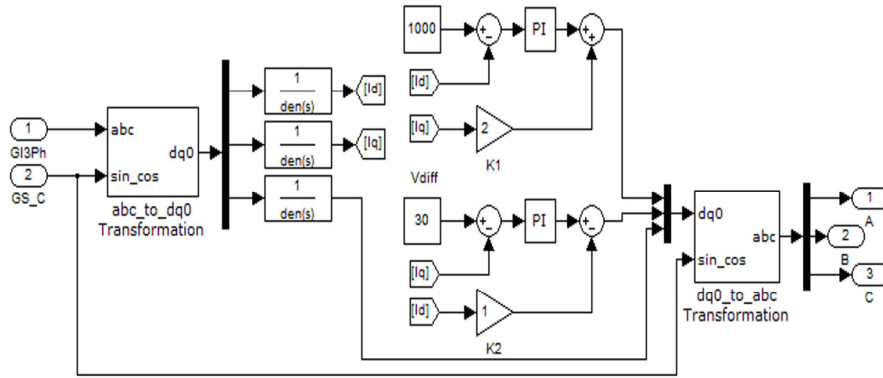
a = corner frequency

To eliminate 100 Hz frequency the value of 'a' is equivalent to 62.8 rad/s

$$\frac{1}{1 + \frac{S}{62.8}} \quad (4.5)$$

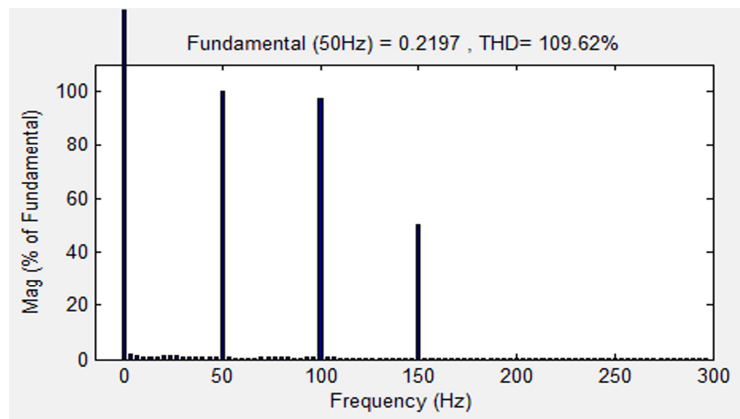
$$\frac{1}{1 + 0.0159S} \quad (4.6)$$



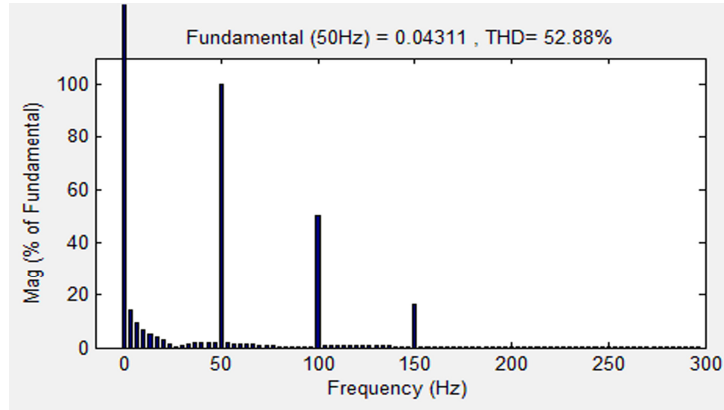


**Fig. 4.33 Simulink Design of Low Pass Filter**

Unbalanced voltage was applied to the SRF-PLL design and the FFT was done before and after the low pass filter. The unbalanced signal has resulted in second and third harmonic and LPF has reduced the harmonic content to a considerable level. The THD was also minimised from 109.62 % to 52.88 %, which can be observed in Fig. 4.34 and 4.35.



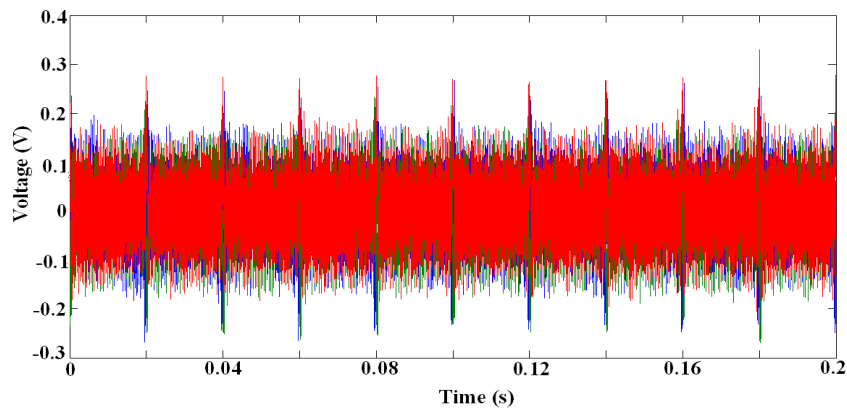
**Fig. 4.34 FFT of Unbalance Input Spectrum for SRF-PLL**



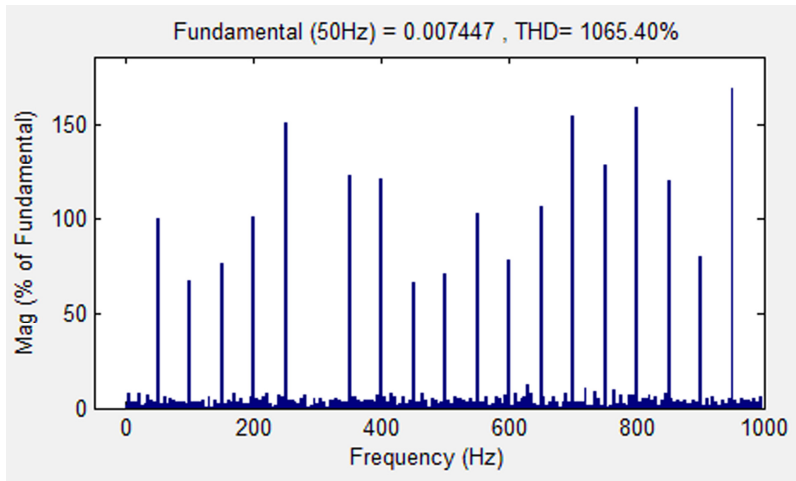
**Fig. 4.35 FFT of the Output Spectrum Measured after LPF**

To mimic the worst case grid scenario, randomly generated harmonic signals are added to the fundamental and given as the reference for SRF-PLL as depicted in Fig. 4.36. The FFT analysis of this signal shows the harmonic contents as shown in Fig. 4.37. The output of the SRF-PLL and FFT is shown in Fig. 4.38 and Fig. 4.39. It can be observed that the fundamental frequency component is predominantly present and the THD is reduced to a greater extent from 1065.4 % to 0.32 %.

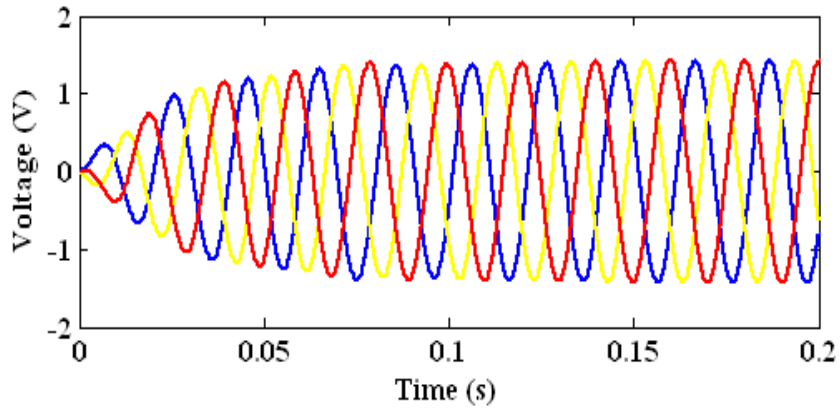
DC components present in Fig. 4.35 are not available in Fig. 4.39. This is eliminated by the filter located at the output of the inverter. Hence the DC components are removed and the voltage applied to the transformer will not saturate the core.



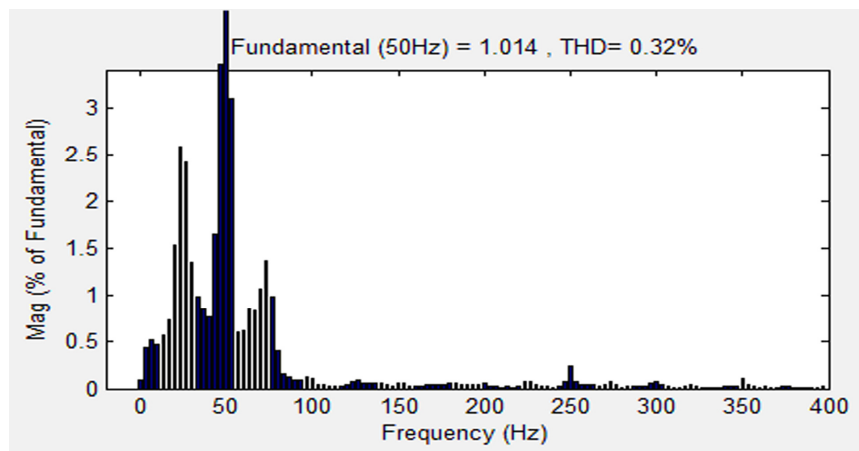
**Fig. 4.36 Harmonic Rich Input Voltage Spectrum for SRF-PLL**



**Fig. 4.37** FFT of the Harmonic Rich Input Spectrum for SRF-PLL



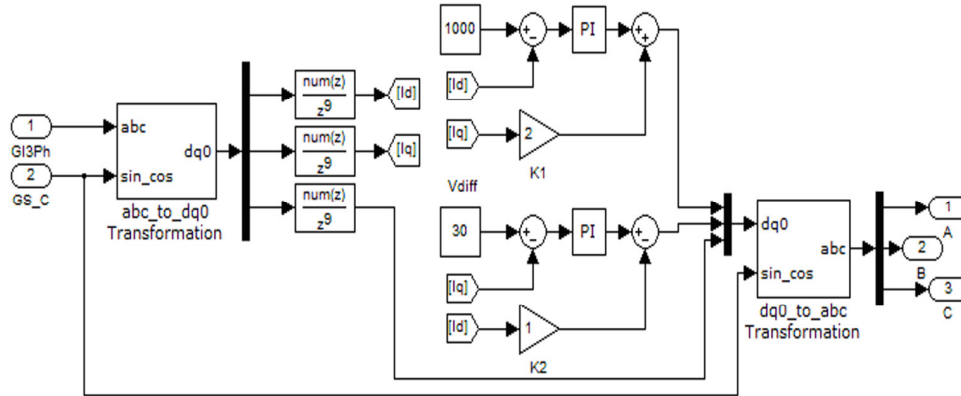
**Fig. 4.38** Output Voltage Spectrum for SRF-PLL Designed with Low Pass Filter



**Fig. 4.39** FFT for SRF-PLL Designed with Low Pass Filter

### 4.6.3.2 DESIGN OF MOVING AVERAGE FILTER

A moving average filter is designed to eliminate the second harmonic issues resulted by grid unbalance conditions. The simulink model of the SRF-PLL method with MAF is shown in Fig. 4.40.

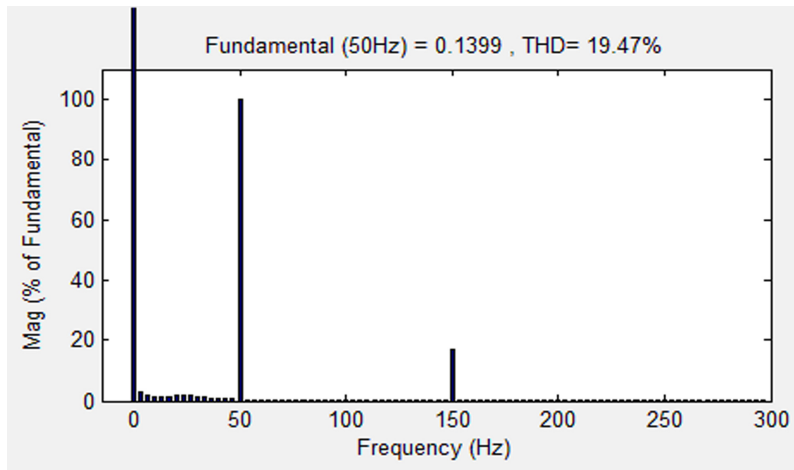


**Fig. 4.40 Simulink Design of Moving Average Filter**

The signal containing 100 Hz component is sampled at a rate of 1 kHz and at every computational instant average of 10 samples (which includes the previous 9 samples) is calculated then output would not contain 100 Hz and it's integral harmonics up to 500 Hz (decided by Nyquist criteria). Transfer function of such a filter in discrete domain is given by the following equation, [Barbosa et al, 2006]

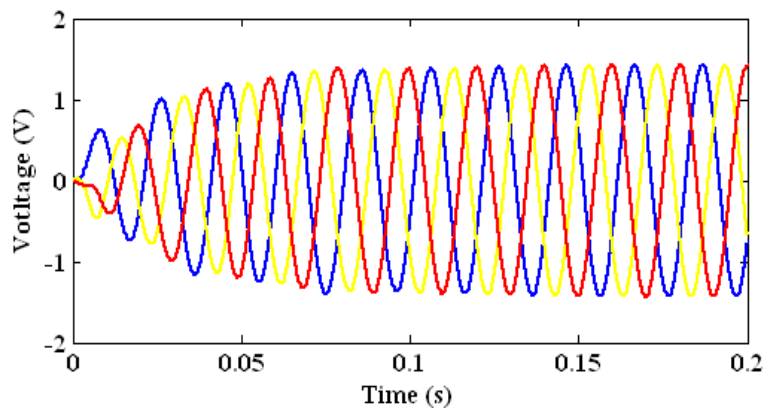
$$H(z) = 0.1(1 + Z^{-1} + Z^{-2} + \dots + Z^{-9}) \quad (4.7)$$

Unbalanced voltage was applied to the SRF-PLL design similar to the LPF design and the FFT was captured before and after the MAF. The unbalance signal has resulted in second harmonic and MAF has eliminated it to a considerable level. The THD is also minimised from 109.62 % to 19.47 % which can be observed in Fig. 4.34 and Fig. 4.41.

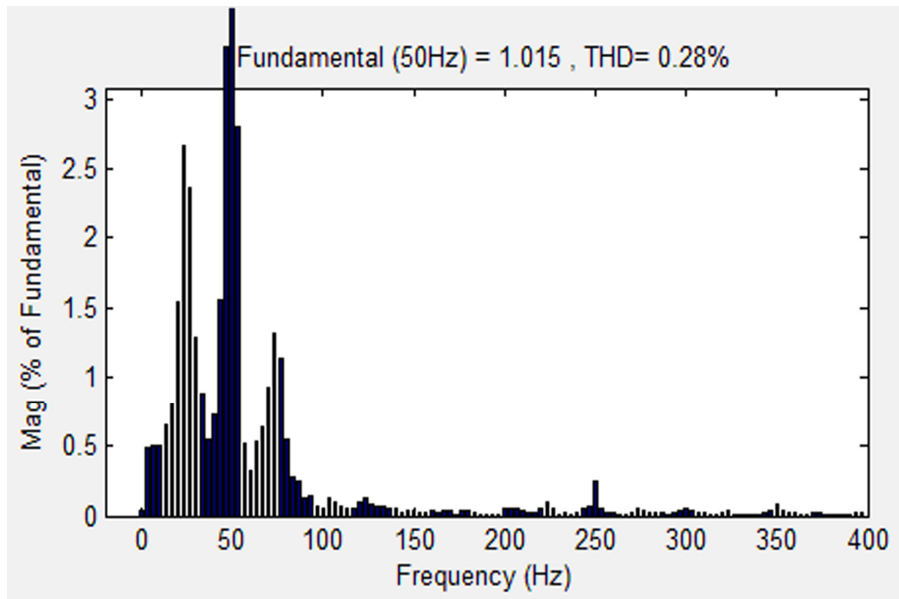


**Fig. 4.41 FFT of the Output Spectrum Measured after MAF**

A similar harmonic rich input which was given as reference to the LPF design, was given to the MAF design. The output of the SRF-PLL and the FFT is shown in Fig. 4.42 and Fig. 4.43. It can be observed that the fundamental frequency is predominantly present and the THD is reduced from 1065.4% to 0.28%.as shown in Fig. 4.37 and Fig. 4.43. DC components are present in both cases, but they can be eliminated using the elimination methods specified in IEEE 929 standard.



**Fig. 4.42 Output Voltage Spectrum for SRF-PLL Designed with MAF**



**Fig. 4.43 FFT for SRF-PLL Designed with MAF**

The current harmonics have their magnitudes decreasing with increasing order; an  $h^{\text{th}}$  order harmonic has magnitude  $1/h$  times the fundamental [Kundur, 2011]. The harmonic contents in the current output for each method is tabulated in Table 4.4, where the comparison has been made with IEC 61727 standard available for grid interactive inverters to check the limits. No deviations were found in the results obtained using the proposed model.

Introducing a filter in zero cross detection method would also produce a better output. However, since this filter is not a digital filter, it would have the following disadvantages.

- Bulky
- Consumes more space
- Expensive
- Consumption of greater reactive power
- Complicates engineering design and interlocks due to addition of equipment
- Addition of relays to protect the equipment

**Table 4.4 Current Harmonics Distortion of SRF-PLL with and without Filter**

Standard		Simulation Results		
IEC 61727		Without Filter	With LPF	With MAF
Harmonics	Limit (%)	%	%	%
3	< 4	0.08	0.09	0.1
5	< 4	0.27	0.28	1.52
7	< 4	0.13	0.13	0.87
9	< 4	0.03	0.03	0.01
2	< 1	0.13	0.13	0.07
4	< 1	0.08	0.09	0.05
6	< 1	0.09	0.09	0.06
8	< 1	0.04	0.04	0.04
11	< 2	0.05	0.05	0.47
13	< 2	0.03	0.03	0.36
15	< 2	0.01	0.01	0.03
10	< 0.25	0.03	0.03	0.05
12	< 0.25	0.02	0.02	0.04
14	< 0.25	0.02	0.02	0.01
17	< 1.5	0.01	0.01	0.29
23	< 0.6	0.01	0.01	0.23
33	< 0.6	0.01	0.01	0.03

## 4.7 CONCLUSION

The systems required for grid interconnection has been designed and various control technique has been tested and the performance of the system is recorded. Filter design parameter for 50 Hz, delta star transformer with OLTC mechanism and a synchronization check verification relay design is discussed. Existing synchronization techniques and the proposed SRF-PLL synchronization technique has been tested for various grid scenarios and the response of the system is tabulated.

It is concluded that the ZCD technique has failed for harmonics and the PCU quality is affected for load variation. CP-PLL technique has responded well for load variations but it cannot differentiate between phase angle variation due to load variations and harmonics. SRF-PLL technique has responded positively for both harmonics and load variations condition. Two filters namely LPF and MAF were designed to verify the 2<sup>nd</sup> harmonic suppression capability and MAF has responded satisfactorily. However SRF-PLL without filter complies with harmonic suppression standards.



## **CHAPTER 5**

### **RESULTS AND DISCUSSION**

#### **5.1 INTRODUCTION**

In this chapter the results of ZCD, CP-PLL and SRF-PLL synchronization technique has been verified for compliance against IEEE 929 standard meant for grid interactive inverters. Harmonic suppression capability of these techniques are cross checked with IEC 61727 and IEEE 1547 standard meant for 10 kW and 30 kW systems respectively. The synchronization tolerance limits as per ANSI 25 is also verified.

#### **5.2 COMPLIANCE OF RESULTS AS PER IEEE 929 STANDARD**

Power system disturbances are usually followed by load throw, DC transients and harmonics. CP-PLL and ZCD techniques have failed for harmonic conditions. Phase angle mismatch between PCC and PCU is addressed in CP-PLL technique. Phase angle difference can be due to load variations or harmonics and CP-PLL cannot distinguish between these two conditions. This overthrows the advantages of CP-PLL since the system goes out of synchronization violating IEEE 929 standard. SRF-PLL technique can eliminate harmonics and follow the phase angle variation in grid reference during load variations thus complies with the standard.

To feed real power to the grid, the voltage output of the PCU should be greater than the PCC. This concept is taken care by the use of DC-DC boost converter in the DC circuit and a transformer with on load tap changer mechanism in the AC circuit. The measurement of real power, reactive power and current generated by the grid and the SPV system is shown in Fig. 4.11 to Fig. 4.13.

### **5.3 COMPLIANCE OF RESULTS AS PER IEC 61727 / IEEE 1547 STANDARD**

All the synchronization techniques such as ZCD, CP-PLL and the SRF-PLL have been taken for investigation and the results are presented here. ZCD and CP-PLL techniques have failed for harmonics. The results of SRF-PLL with MAF and LPF are found to be within the limits specified by IEC 61727 and IEEE 1547. The LPF and the MAF designs were tested for rich harmonic contents and the results show that the MAF is better than LPF due to lesser THD and complete elimination of second harmonics. The proposed system can be extended for auto-reclose scheme where synchronization check is required even before circuit breaker close command is issued. Further this work can be used for load frequency control of grid connected SPV systems.

### **5.4 COMPLIANCE OF RESULTS AS PER ANSI C84.1 / ANSI 25 STANDARD**

The synchronization of the PCU and PCC complies with ANSI 25 standard. Fig. 4.6 to Fig. 4.8 shows the different in voltage magnitude, phase angle and frequency between PCU and PCC. The magnitude difference tolerance can be increased to comply with IEEE 929 standard for feeding real power to the grid thus the designed model has the facility to dynamically modify the tolerance limit to adjust between the two standards.

The voltage protection of the system is taken care by designing the grid coupling transformer to operate in a safe voltage limit specified by ANSI C84.1 standard. This being common equipment in all the three techniques, all techniques will be complied with this standard however in the presence of harmonics, core saturation and 5<sup>th</sup> harmonic protection in transformer protection relays can trip the transformer thereby isolating the SPV system from the grid. Harmonic conditions are handled by SRF-PLL technique which prevents an islanding scenario. Hence one can conclude that SRF-PLL technique is the only technique complying with this standard.

## 5.5 COMPARISON OF RESULTS OF EXISTING AND PROPOSED TECHNIQUES AGAINST VARIOUS STANDARDS

Grid Scenarios	Synchronization Techniques		
	ZCD	CP-PLL	SRF-PLL
Angle between PCC and PCU	Fail	IEEE 929	IEEE 929 ANSI 25
Harmonics	Fail	Fail	IEC 61727 IEEE 1547
Power Quality	Fail	IEEE 929	IEEE 929
Grid Islanding	Fail	Fail	IEEE 929 ANSI C84.1

ZCD fails in the presence of Harmonics resulting in power quality issues which can pull out the system if the angle difference is greater than  $10^\circ$  between PCC and PCU (IEEE 929 standard)

CP-PLL complies with IEEE 929 standard by matching the phase angle difference between PCC and PCU but fails for harmonics. It cannot differentiate between phase angle change due to harmonics and load variations and hence it does not comply with standards

SRF-PLL complies with IEEE 929 standard by matching the phase angle difference between PCC and PCU

SRF-PLL eliminates harmonic issues and complies to IEC and IEEE standard

The angle difference between PCC and PCU permitted in IEEE 929 standard is  $10^\circ$  which will still create a power quality issue. Any angle greater than  $10^\circ$  will result in grid islanding situation

SRF-PLL follows the grid (angle difference between PCC and PCU is always maintained as zero) and hence it supersedes the standard there by preventing a grid islanding scenario which can occur in existing methods

## **5.6 CONCLUSION**

The verification of results show that all the existing control techniques have failed when subjected to harmonics and load variations. The proposed SRF-PLL technique complies with all the standards and the results are well within the tolerance limit prescribed in the standard. It has been tested for various harmonics, load variations and also system unbalance conditions which are likely to occur in grid connected systems and the output is complied.

## **CHAPTER 6**

### **CONCLUSION AND RECOMMENDATION**

#### **6.1 CONCLUSION**

A detailed review on the existing literature shows that grid connected SPV system and their compliance with grid standard is scarcely discussed. A closer view shows that this literature gap is due to the fact that frequency parameter cannot be varied easily. Synchronization being one of the parameter which depends on frequency, it has been chosen as the focus of this research work.

The mathematical model of SPV system was modeled and the voltage, current and power characteristics were plotted. Analysis of these characteristics showed the SPV system relationship with irradiation and temperature which further led to the design of DC-DC converter with MPPT algorithm. P&O and INC MPPT algorithms were simulated and the DC converter was designed using these algorithms. To convert the DC to AC, a three phase inverter was designed and the voltage was recorded.

The systems required for grid interconnection has been designed and various control technique has been tested and the performance of the system is recorded. Filter design parameter for 50 Hz, delta star transformer with OLTC mechanism and a synchronization check verification relay design is discussed. Existing synchronization techniques and the proposed SRF-PLL synchronization technique has been tested for various grid scenarios and the response of the system is tabulated.

It is concluded that the ZCD technique has failed for harmonics and the PCU quality is affected for load variation. CP-PLL technique has responded well for load variations but it cannot differentiate between phase angle variation due to load variations and harmonics. SRF-PLL technique has responded

positively for both harmonics and load variation condition. Two filters namely LPF and MAF were designed to verify the 2<sup>nd</sup> harmonic suppression capability and MAF has responded satisfactorily. However SRF-PLL without filter complies with harmonic suppression standards.

## **6.2 RECOMMENDATION FOR FUTURE WORK**

Frequency depended features are affected due to the problems explained in this work which are summarized as,

1. Synchronization
2. Load frequency control
3. Active power control
4. Reactive power control

This thesis mainly focuses on the synchronization techniques. The other three frequency dependent features can be taken as future scope. The simulated model will be a base model for future work.

## REFERENCES

### Books

**Barbosa Rolim, L G B., Rodrigues da Costa Jr, D R., & Aredes, M. (2006),** Analysis and Software Implementation of a Robust Synchronizing PLL Circuit Based on the pq Theory, IEEE Transactions on Industrial Electronics, 1919-1926.

**Bureau of Energy Efficiency, Ministry of Power, Govt. of India.,** General Aspects of Energy Management and Energy Audit, New Delhi, 2005.

**Central Electricity Authority, Ministry of Power, Govt. of India.,** National Electricity Plan, Vol. 1, January 2012.

**David Sanz Morales,** Maximum Power Point Tracking Algorithms for Photovoltaic Applications, Aalto University School of Science and Technology, 2010.

**John A Duffie and William A Beckman,** Solar Engineering of Thermal Processes, John Wiley & Sons, Inc. New York, 1980.

**Kundur Prabha,** Power System Stability and Control, Tata McGraw Hill Education Private Limited, New Delhi, 2011.

**Mateus F. Schonardie and Denizar C. Martins (2008).** Three-Phase Grid connected photovoltaic system with active and reactive power control using dq0 transformation. Power Electronics Specialists Conf., 1202-1207.

**Muhammad H. Rashid,** Power Electronics, Third edition, Dorling Kindersley (India) Pvt. Ltd., licensees of Pearson Education in South Asia, 2004.

**Mukerjee A.K and Nivedita Thakur,** Photovoltaic Systems Analysis and Design, PHI Learning Private Limited, New Delhi, 2011.

**Ramaprabha R and Mathur B.L,** "Effect of shading on series and parallel connected solar PV modules," Journal of modern applied science, vol. 3, no. 10 pp, 32-41, 2009.

Rosaidi Bin Roslan, A Maximum Power Point Tracking Converter for Photovoltaic Application, Universiti Teknologi Malaysia, 2009.

Sukhatma S.P, Solar Energy, Principles of Thermal Collection and Storage, Tata McGraw-Hill Publishing Company Limited, New Delhi, 1992.

Swanand Vishnu Solanke, “Design and Analysis of Novel Charge Pump Architecture for Phase Locked Loop”, Thesis, Dept. of Electronics and communication Engineering, National Institute of Technology, Rourkela, 2007-2009.

Tiwari G.N, Solar Energy Fundamentals Design Modelling and Applications, Narosa Publishing House Pvt. Ltd., New Delhi, 2010.

Transformers, Second Edition, Tata McGraw-Hill Publishing Company Limited, New Delhi, 2008.

### **Websites**

- [1] <http://indianpowersector.com/home/tag/12th-plan/>
- [2] <http://www.powergridindia.com/layouts/PowerGrid/User/ContentPage.aspx?Pid=78&LangID=English>
- [3] <http://www.energyandcapital.com/articles/india-to-double-solar-target/2346>
- [4] <http://tejas-iimb.org/articles/75.php>
- [5] [http://www.fsec.ucf.edu/en/consumer/solar\\_electricity/basics/types\\_of\\_pv.htm](http://www.fsec.ucf.edu/en/consumer/solar_electricity/basics/types_of_pv.htm)

### **Standards**

1. IEEE 929 standard
2. IEC 61727 standard
3. IEEE 1547 standard
4. ANSI C84.1
5. ANSI 25



## LITERATURE REVIEW REFERENCES

### A. Stand-Alone SPV System

#### **J Applebaum**

IEEE Transactions on Energy Conversion, Vol. EC-2, No.4, Dec 1987, 0885-8696/87/1200-0534 IEEE

International

*Quality of load matching in a direct-coupling photovoltaic system*

#### **Mohanlal Kolhe, J C Joshi and D P Kothari**

IEEE Transactions on Energy Conversion, Vol.19, No.3, Sep 2004, 0885-8969/04, 2004 IEEE, DOI: 10.1109/TEC.2004.827032

International

*Performance analysis of a directly coupled photovoltaic water-pumping system*

#### **Alex See Kok Bin, Shen Weixiang, Ong Kok Seng, Saravanan Ramanathan and Low I-Wern**

Third IEEE International Workshop on Electronic Design, Test and Applications, 0-7695-2500-8/05, 2005 IEEE

International

*Development of a Labview-based test facility for standalone PV systems*

#### **A Braunstein and Z Zinger**

IEEE Transactions on Power Apparatus and System, Vol. PAS-100, No.3, Mar 1981

International

*Dynamic optimal coupling of a solar cell array to a load and storage batteries*

#### **Kame Y Khouzam**

IEEE Transaction on Energy conversion, Vol.5, No.2, June 1990, 0885-8696/90/0600-0265, IEEE

International

*Optimum load matching in direct-coupled photovoltaic power system – Application to resistive loads*

**Kame Y Khouzam and Lucy Khouzam**

CH2953-8/91/0000-0733, 1991 IEEE

International

*Matching of direct-coupled electromechanical loads and a PV array*

**Kame Y Khouzam and Lucy Khouzam**

IEEE Transactions on Energy conversion, Vol.8, No.3, Sep 1993, 0885-8969/93, 1992 IEEE

International

*Optimum matching of direct coupled electromechanical loads to a photovoltaic generator*

**Reza Gharakhany, Mustafa Mohamadian, Ali Yazdian Varjani**

978-1-4244-4241-6/09, 2009 IEEE

International

*Reactive power compensation using Z-source based photovoltaic system*

**C Cavallaro, S Musumeci, C Santonocito, M Pappalardo**

SPEEDAM 2010, International Symposium on Power Electronics, Electrical Drives, Automation and Motion, 978-1-4244-4987-3/10, 2010 IEEE

International

*Load priority control strategy for Solar Photovoltaic-Uninterruptible Power Supply system*

**Xiong Liu and Peng Wang**

Nanyang Technological University, Singapore, 978-1-4244-7398-4/10, 2010 IEEE

International

*Hybrid AC/DC Micro-Grid*

**C Cavallaro**

University of Catania, Italy, 978-1-4244-8930-5/11, 2011 IEEE

International

*Smart load priority control for a SPV-UPS*

**Chee Sing Lee**

Oregon State University University Honors College, June 2008

International

*Residential DC distribution system with Photovoltaic Array Integration*

**Deema Al-Baik and Vinod Khadkikar**

Electrical Power Engineering, Masdar Institute of Science and Technology,  
Abu-Dhabi, UAE

National

*Effect of variable PV power on the grid power factor under different load conditions*

**Jutturit Thongpron, Surasak Yusawat and Krissanapong Kirtikara**

15<sup>th</sup> International Photovoltaic Science and Engineering Conference (PVSEC-15), Shanghai, China, 2005

International

*PV-Grid connected system on its complex output power and impedance*

**Parimita Mohanty, G.Bhuvaneswari and R.Balasubramanian**

The Energy and Resources Institute (TERI) and IIT Delhi

National

*On-field performance assessment of power converters of solar PV system under different operating conditions*

## **B. Control of Grid connected system**

**K Y Lim, Y Wang and R Zhou**

IEEE Proceedings – Generation, Transmission, Distribution Vol.143, No.5,  
September 1996

International

*Robust decentralized load-frequency control of multi-area power systems*

**A P Sakis Meliopoulos, George J Cokkinides and A G Bakirtzis**

Proceedings of 31<sup>st</sup> Hawaii International Conference

Vol.3, pp. 24-31, 1998, DOI : 10.1109/HICSS.1998.656008

International

*Load frequency control service in a deregulated environment*

**Hossein Shayeghi and Heidar Ali Shayanfar**

Journal of Electrical Engineering, Vol.55, No.11-12, 2004

International

*Automatic generation control of interconnected power system using ANN technique based on  $\mu$  - synthesis*

**N Gibo, K Takenaka and M Takasaki**

PSCE 2006, 1-4244-0178-X/06, 2006 IEEE

International

*Voltage control performance of typical wind farm grid connection schemes*

**Risheng Li, S Bozhko, G M Asher, J C Clare, Liangzhong Yao, Christian Sasse**

IEEE ISIE 2006, July 9-12, 2006, Montreal, Quebec, Canada, 1-4244-0497-5/06, 2006 IEEE

International

*Grid Frequency control design for Off shore Wind Farms with Naturally commutated HVDC link connection*

**R Li, S V Bozhko and G M Asher**

The 33<sup>rd</sup> Annual conference of the IEEE Industrial Electronics Society (IECON), Nov.5-8, 2007, Taipei, Taiwan, 1-4244-0783-4/07, 2007 IEEE

International

*Grid Frequency control for LCC HVDC link connected wind farm*

**R Pearmine, Y H Song and A Chebbo**

IET Renewable Power Generation, 2007, 1(2), pp.142-150, DOI:10.1049/iet-rpg:20060003

International

*Influence of wind turbine behavior on the primary frequency control of the British transmission Grid*

**K Sabahi, A Sharifi, M Aliyari, M Teshnehlab and M Aliasghary**

Journal of Applied Sciences, Vol. 8(20), 3676-3682, 2008, ISSN 1812-5654

International

*Load frequency control in interconnected power system using multi-objective PID controller*

**C Marinescu and I Serban**

978-1-4244-4936-1/09, 2009 IEEE

International

*Analysis of frequency stability in a residential autonomous microgrid based on a wind turbine and a microhydro power plant*

**Gayadhar Pande, Sidhartha Panda and Cemal Ardil**

World Academy of Science, Engineering and Technology 52, 2009

International

*Automatic generation control of interconnected power system with generation rate constraints by hybrid neuro fuzzy approach*

**I A Chidambaram and B Paramasivam**

International Journal of Electronic Engineering Research ISSN 0975-6450,

Vol.1, No.4, pp. 299-312, 2009

International

*Genetic algorithm based decentralized controller for load frequency control of interconnected power systems with RFB considering TCPS in the tie line*

**Lingling Fan, Zhixin Miao and Dale Osborn**

IEEE Transactions on Power Systems, Vol.24, No.4, November 2009, 0885-

8950, 2009 IEEE, DOI:10.1109/TPWRS.2009.2030256

International

*Wind Farms with HVDC delivery in Load Frequency control*

**Manoj Datta, Tomonobu Senjyu, Atsushi Yona and Toshihisa Funabashi**

PEDS2009

International

*A frequency control method for isolated photovoltaic-diesel hybrid power system with use of full renewable energy*

**S Alepuz, S Busquets-Monge, J Bordonau, P Cortes and S Kouro**

978-1-4244-2893-9/09, 2009 IEEE

International

*Control methods for Low voltage ride-through compliance in Grid-connected NPC converter based wind power systems using predictive control*

**W Kuehn**

978-1-4244-3811-2/09, 2009 IEEE

International

*Control and stability of power inverters feeding renewable power to weak AC grids with no or low mechanical inertia*

**Z Wang, Y Sun, G Li and B T Ooi**

IET Renewable Power Generation, 2012, Vol.4, Iss.3, pp.232-241, ISSN 1752-1416, DOI: 10.1049/iet-rpg.2009.0088

International

*Magnitude and Frequency control of Grid-connected doubly fed induction generator based on synchronized model for wind power generation*

**A Chatterjee, S P Ghoshal and V Mukherjee**

International Journal on Electrical Engineering and Informatics, Vol. 2, No. 3, 2010

International

*Transient performance improvement of thermal system connected to grid using distributed generation and capacitive energy storage unit*

**B Parashuramulu and Ashwani Kumar**

2010 Annual IEEE India Conference (INDICON),

978-1-4244-9074-5/10 IEEE

International

*Load frequency control of hybrid systems in open access environment*

**A Tahri, A Draou**

University of Sciences and Technology of Oran

National

*Instantaneous active and reactive power measuring method in three phase power*

**J Raja, C Christofer Asir Rajan and S Suresh**

978-1-4244-5967-4, 2010 IEEE

International

*PSO based robust frequency control of wind-diesel power plant using BES*

**K P Singh Parmar, S Majhi and D P Kothari**

978-1-4244-7781-4/10, 2010 IEEE

International

*Multi-area load frequency control in a power system using optimal output feedback method*

**Koichiro Shimizu, Taisuke Masuta, Yuyaka Ota and Akihiko Yokoyama**

2010 International Conference on Power System Technology, 978-1-4244-5940-7/10, 2010 IEEE

International

*Load Frequency control in Power system using Vehicle-to-Grid system considering the customer convenience of Electric Vehicles*

**M Ezatabadi Pour and A Khodabakhshian**

978-1-4244-5795-3/10, 2010 IEEE

International

*A new robust load frequency control design using sequential quadratic programming (SQP) method*

**P K Ray, S R Mohanty, Nand Kishor**

Journal of Electrical Engineering Theory and Application, Vol.1-2010/Iss.1, pp. 24-31

International

*Dynamic Load- frequency control of hybrid renewable energy based power system with HVDC link*

**S.Ramesh, A Krishnan**

2010 International Journal of Computer Applications (0975-8887), Vol.1,  
No.4

International

*Fuzzy rule based load frequency control in a parallel AC-DC interconnected power systems through HVDC link*

**Taisuke Masuta, Akihiko Yokoyama and Yasuyuki Tada**

2010 International conference on Power System Technology, 978-1-4244-5940-7/10, 2010 IEEE

International

*System Frequency control by heat pump water heaters (HPWHs) on customer side based on statistical HPWH model in Power system with a Large Penetration of Renewable Energy sources*

**Temesgen M Haileselassie and Kjetil Uhlen**

978-1-4244-6551-4/10, 2010 IEEE

International

*Primary Frequency control of remote Grids connected by multi-terminal HVDC*

**Balazs Mariscsak, Zoltan Tatai and Seoung Young Koo**

8<sup>th</sup> International conference on Power Electronics – ECCE Asia, May 30 – June 3, 2011, The Shilla Jeju, Korea,

978-1-61284-957-7/11, 2011 IEEE

International

*Simulation and rapid prototyping system for Grid connected wind Inverters*

**Hassan Bevrani and Pourya Ranjbar Daneshmand**

IEEE Systems Journal, Vol.6, No.1, March 2012, DOI:10.1109/JSYST.2011.2163028, 1932-8184, 2011 IEEE

International

*Fuzzy logic based Load-Frequency control concerning High Penetration of Wind Turbines*



**I A Gowaid, A El-Zawawi and M El-Gammal**

978-1-61284-788-7/11, 2011 IEEE

International

*Improved Inertia and Frequency support from Grid-connected DFIG wind farms*

**J Dai, Y Phulpin, A Sarlette and D Ernst**

IET Gener. Transmission and Distribution, Vol.6, Iss.2, pp.99-108, 2011,

DOI:10.1049/iet-gtd. 2011. 0312

International

*Coordinated primary frequency control among non-synchronous systems connected by a multi-terminal high-voltage direct current grid*

**M M Amin, O A Mohammed**

978-1-4244-8085-2/11, 2011 IEEE

International

*Development of a Grid-connected wind generation system utilizing high frequency-based three-phase semi controlled rectifier-current source inverter*

**R Dhanalakshmi and S Palaniswami**

European Journal of Scientific Research, ISSN 1450-216X, Vol.60, No.4, 2011, pp.630-641

International

*Load frequency control of wind diesel hydro hybrid power system using conventional PI Controller*

**Reza Hemmati, Sayed Mojtaba Shirvani Boroujeni, Hamideh Delafkar and Amin Safarnezhad Boroujeni**

Australian Journal of Basic and Applied science, 5(3): 295-302, 2011, ISSN 1991-8178

International

*PID Controller adjustment using PSO for multi area load frequency control*

**Sathans and Akhilesh Swarup**

International Conference on Communication Systems and Network Technologies – 2011, 978-0-7695-4437-3/11, IEEE, DOI: 10.1109/CSNT.2011.81

International

*Intelligent load frequency control of two-area interconnected power system and comparative analysis*

**Sayed Mojtaba Shirvani Boroujeni, Babak Keyvani Boroujeni, Mostafa Abdollahi and Hamideh Delafkar**

Australian Journal of Basic and Applied Sciences, Vol. 5(9), 2011, ISSN 1991-8178

International

*Multi-area load frequency control using Ip controller tuned by harmony search*

**Temesgen M Haileselassie, Raymundo E Torres-Olguin, Til Kristian Vrana, Kjetil Uhlen and Tore Undeland**

IEEE Trondheim Power Tech, 978-1-4244-8417-1/11, 2011 IEEE

International

*Main Grid Frequency support strategy for VSC-HVDC connected Wind Farms with Variable Speed Wind Turbines*

**V Shanmuga Sundaram and T Jayabarathi**

978-1-61284-379-7, 2011 IEEE

International

*Load frequency control using PID tuned ANN controller in power system*

**Yannick Phulpin**

IEEE Transactions on Power Systems, Vol.27, No.2, May 2012, DOI:10.1109/TPWRS.2011.2175817, 0885-8950, 2011 IEEE

International

*Communication-Free Inertial and frequency control for wind generators connected by an HVDC-link*

**Yuvaraj V, S N Deepa, A P Roger Rozario and Madhusudan Kumar**

Fifth Asia Modeling Symposium, DOI: 10.1109/AMS.2011.38, 978-1-7695-4414-4/11, 2011 IEEE

International

*Improving Grid Power Quality with FACTS Device on Integration of Wind Energy system*

**L Clotea and A Forcos**

978-1-4673-1653-8/12, 2012 IEEE

International

*Power Losses evaluation of two and three-level NPC inverters considering drive Applications*

**S M Muyeen, H M Hasanien and J Tamura**

IET Renewable Power Generation, IET Renew. Power Gener, 2012, Vol.6, Iss.4, pp. 226-235, DOI: 10.1049/iet-rpg. 2010.0126

International

*Reduction of frequency fluctuation for wind farm connected power systems by an adaptive artificial neural network controlled energy capacitor system*

**G. Fujita, K Ezaki, T Nakano, R Yokoyama, K Koyanagi and T Funabashi**

IEEE Bologna Power Tech conference, June 23-26,2003, 0-7803-7976-5/03  
IEEE

International

*Dynamic characteristic of frequency control by rotary frequency converter to link wind farm and power system*

**Hassan Bevrani, Yasunori Mitani, Kiichiro Tsuji**

SICE Annual conference in Fukui, August 4-6, 2003

National

*A scenario on load-frequency controller design in a deregulated power system*

**K S S Ramakrishna and T S Bhatti**

International Conference on Energy and Environment (ICEE), August 2006

International

*Load frequency control of interconnected hydro-thermal power systems*

**Y Zhou, J A Ferreira and P Bauer**

IEEE PES Power Africa 2007 conference and Exposition, Johannesburg, South Africa, 16-20 July 2007, 1-4244-1478-4/07, 2007 IEEE

International

*Grid-connected and islanded operation of a hybrid power system*

**Risheng Li, Serhiy Bozhko and Greg Asher**

IEEE Transactions on Power Electronics, Vol.23, No.3, May 2008, DOI:10.1109/TPEL.2008.921193, 0885-8993, 2008 IEEE

International

*Frequency control design for Offshore wind farm Grid with LCC-HVDC link connection*

**A Sharifi, K Sabahi, M Aliyari Shoorehdeli, M A Nekoui and M Teshnehlab**

2008 IEEE Conference on Soft Computing in Industrial Applications (SMCia/08), June 2008, 978-1-4244-3782-5/08 IEEE

International

*Load frequency control in interconnected power system suing multi-objective PID controller*

**Prabhat Kumar and Ram Naresh Mishra**

XXXII National Systems Conference, NSC 2008, December 17-19, 2008

National

*Optimal control of 3-area interconnected hydro-thermal power systems with EHV AC/HVDC links*

**Lingling Fan, Zhixin Miao and Dale Osborn**

IEEE Transactions on Power Systems, Vol.24, No.4, November 2009

DOI : 10.1109/TPWRS.2009.2030256, 0885-8950, 2009 IEEE

International

*Wind Farms with HVDC delivery in Load Frequency control*

**S Ganapathy and S Velusami**

International Journal of Computer and Electrical Engineering,  
Vol.2, No.1, February 2010, 1793-8163

International

*Design of MOEA based decentralized load frequency controllers for interconnected power systems with nonlinearities and SMES units*

**M Ezatabadi Pour, A Khodabakhshian and R Hooshmand**

Proceedings of ICEE 2010, May 2010, 978-1-4244-6760-0/10 IEEE

International

*A new design approach to load frequency control tuning*

**R Arivoli, G Gurumoorthy and I A Chidambaram**

IACSIT – International Journal of Engineering and Technology, Vol. 3, No.1,  
February 2011, ISSN:1793-8236

International

*Design of a new area control error based load frequency controller for a two area interconnected power system*

**Manoj Datta, Tomonobu Senjyu, Atsushi Yona, Toshihisa Funabashi and Chul-Hwan Kim**

IEEE Transactions on Energy Conversion, Vol.26, No.2, June 2011, 0885-8969 IEEE, DOI:10.1109/TEC.2010.2089688

International

*A frequency-control approach by photovoltaic generator in a PV-diesel hybrid power system*

**Tan Wen and Zhang Jifen**

Proceedings of the 30<sup>th</sup> Chinese Control Conference, July 2011, Yantai, China

International

*Load Frequency control for wind-diesel hybrid systems*

**A Madureira, C Moreira, J Pecas Lopes**

Power system unit of INESC, Portugal

National

*Secondary load-frequency control for micro grids in islanded operation*

**Armin Ebrahimi Milani, Babak Mozafari**

Global Journal of Technology and Optimization, Vol.2, June 2011, ISSN :  
2229-8711

International

*Genetic algorithm based optimal load frequency control in two-area interconnected power systems*

**B Venkata Prasanth, S V Jayaram Kumar**

Journal of Theoretical and Applied Information Technology

International

*New control strategy for load frequency problem of a single area power system using fuzzy logic control*

**B Venkata Prasanth, S V Jayaram Kumar**

Journal of Theoretical and Applied Information Technology

International

*Load frequency control for a two area interconnected power system using robust genetic algorithm controller*

**Badoud Abd Essalam and Khemliche Mabrouk**

2011, 7<sup>th</sup> International Workshop on Systems, Signal Processing and their Applications (WOSSPA), 978-1-4577-0690-5/11 IEEE

International

*Grid-connected modeling, control and simulation of single phase two level photovoltaic power generation system coupled to a permanent magnet synchronous motor*

**Constantinos Parisses, Nikolaos Asimopoulos, Prokopis Fessas**

Technological Educational institute of West Macedonia, Greece

International

*Decentralized load-frequency control of a two area power system via linear programming and optimization techniques*

**Emre Ozkop, Ismail H Altas, Adel M Sharaf**

16<sup>th</sup> National Power System Conference, December 2010

National

*Load frequency control in four area power systems using fuzzy logic PI controller*

**Fredi Z Ferrigolo, Diego B Ramos, Jeferson M Correa, Felix A Farret, Luciano P Lima**

978-1-4244-4649-0/09, IEEE

International

*Advanced high frequency AC Microgrid with integrated power quality conditioning capability*

**Gillian R Lalor**

The National University of Ireland, Thesis

International

*Frequency control on an island power system with evolving plant mix*

**H Shayeghi and H A Shayanfar**

IJE Transactions B: Applications

Vol. 16, No.3, October 2003

International

*Application of ANN Technique for interconnected power system load frequency control*

**H Trinh and M Aldeen**

IEE International Conference on Advances in Power System Control, Operation and Management, Hong Kong, November 1991

International

*Decentralized load-frequency control of interconnected power systems*

**K S S Ramakrishna, T S Bhatti**

Centre for Energy Studies, IIT Delhi

National

*Load Frequency control of Single Area Power systems having multi-source power generation*

**K Sabahi, M A Nekoui, M Teshnehlab, M Aliyari and M Mansouri**

Proceedings of the 15<sup>th</sup> Mediterranean Conference on Control and Automation, Athens, Greece, July 2007

National

*Load Frequency control in interconnected power system using modified dynamic neural networks*

**Ma Yiwei, Yang Ping and Wang Jiancheng**

*Guangdong key laboratory of clean energy technology*

National

*Control strategy of doubly-fed wind turbine generator-MW level*

**Nishad Mendis, Kashem M Mittaqui, Sayeef and Sarath Perera**

978-1-4244-5226-2/10 IEEE

International

*A control approach for voltage and frequency regulation of a wind-diesel-battery based hybrid remote area power supply system*

**R Li, S V Bozhko, G M Asher and L Yao**

University of Nottingham, UK

National

*Grid Frequency control design for Off shore wind farms with naturally commutated HVDC link connection*

**S Bhowmik, K Tomsovic**

Pullman, USA, IEEE

International

*Communication Models for third party load frequency control*

**Sayed Mojtaba Shrivani Boroujeni, Reza Hemmati, Hasan Fayazi Boroujeni**

International Journal of the Physical Sciences, Vol. 6(3), Feb 2011, ISSN 1992-1950

International

*Load frequency control in multi area electric power system using genetic scaled fuzzy logic*



**V Shanmuga Sundaram, T Jayabarathi**

International Journal of Engineering Science and Technology (IJEST), Vol.3,  
No.5, May 2011, ISSN : 0975-5462

International

*An investigation of ANN based PID controllers using three-area load  
frequency control in interconnected power system*

**V Shanmuga Sundaram, T Jayabarathi**

International Journal of Engineering Science and Technology (IJEST), ISSN :  
0975-5462

International

*Load frequency control in multi area power system*

**Yao Zhang**

Tsinghua University, Thesis, July 2007

International

*Load Frequency control of multiple-area power systems*

### **C. Maximum Power Point Tracking Method**

**Toshihiko Noguchi and Hiroyuki Matsumoto**

ISBN:90-75815-07-7, EPE 2003 – Toulouse

International

*Maximum-power point tracking method of photovoltaic using only single  
current sensor*

**Mohamed Della Krachai, Abdelhamid Midoun**

ISSN 1335-8243, 2007

International

*High efficiency maximum power point tracking control in photovoltaic-grid  
connected plants*

**Tomonoby Senjyu, Yasutaka Ochi, Yusuaki Kilunaga, Motoki  
Tokudome, Atsushi Yona, Endusa Billy Muhando, Naomitsu Urasaki and  
Toshihisa Funabashi**

Science Direct, Renewable Energy, Volume 3, Issue 4, Pg. 994-999, April 2009

International

*Sensor-less maximum power point tracking control for wind generation system with squirrel cage induction generator*

**L MacIsaac, A. Knox**

International Conference on Renewable Energies and Power Quality, 23 to 25 March 2010

International

*Improved maximum power point tracking algorithm for photovoltaic systems*

**R Ramaprabha, Badrilal Mathur, K Santhosh, S Sathyanarayanan**

International journal of Emerging trends in engineering and technology (IJETET), Vol.1, No.1, 2011, ISSN 2248-9592

International

*Modeling and simulation of SPVA characterization under all conditions*

**Sh Abdi, K Afshar, N Bigdeli, S Ahmadi**

International journal of electrochemical science, Int.J.Electrochem, Sci., 7(2012)4192-4209

International

*Robust maximum power point tracking of PEM fuel cell generator using sliding mode control approach*

**Mehmet Bodur and Muammer Ermis**

0-7803-1772-6/94 IEEE

International

*Maximum power point tracking for low power photovoltaic Solar panels*

**Yan Hong Lim and D C Hamill**

Electronics Letters 25<sup>th</sup> May 2000, Vol.36 No.11

National

*Simple maximum power point tracker for photovoltaic arrays*

**M Veerachary, T Senjyu and K Uezato**

IEEE Proc-electronics, Power Appl. Vol.150, No.1, Jan 2003

International

*Maximum power point tracking of coupled inductor interleaved boost converter supplied PV system*

**Eftichios Koutroulis and Kostas Kalaitzakis**

IEEE Transactions on Industrial Electronics, Vol.53, No.2, April 2006, 0278-0046 IEEE, DOI:10.1109/TIE.2006.870658

International

*Design of a maximum power tracking system for wind -energy- conversion applications*

**Joung-Hu Park, Jun-Youn Ahn, Bo-Hyung Cho, Gwon-Jong Yu**

IEEE Transactions on Industrial Electronics, Vol.53, No.4, August 2006  
0278-0046 IEEE, DOI:10.1109/TIE.2006.878330

International

*Dual-Module-Based maximum power point tracking control of Photovoltaic system*

**Trishan Eram, Jonathan W Kimball, Philip T Krein, Patrick L Chapman and Pallab Midya**

IEEE Transactions on Power Electronics, Vol.21, No.5 September 2006

International

*Dynamic Maximum power point tracking of photovoltaic arrays using Ripple correlation control*

**Trishan Eram,, Patrick L Chapman**

IEEE Transactions on Energy conversion, Vol.22, No.2, June 2007, 0885-8969 IEEE

International

*Comparison of Photovoltaic array maximum power point tracking techniques*

**A Lay-Ekuakille, G Vendramin, A Fedele, L Vasanelli, A Trotta**

International Journal on Smart Sensing and Intelligent Systems, Vol.1, No.3,  
Sep. 2008

International

*PV maximum power point tracking through pyranometric sensor: Modeling and characterization*

**Joanne Hui**

Queen's Univeristy Kingston, Ontario, Canada, December 2008

International

*An adaptive control algorithm for maximum power point tracking for wind energy conversion systems*

**M I Arteaga Orozco, J R Vazquez, P Salmeron, S P Litran, F J Alcantara**

International conference on renewable energies and power quality (ICREPQ'09), Valencia (Spain), 15<sup>th</sup> to 17<sup>th</sup> April, 2009

International

*Maximum power point tracker of a photovoltaic system using sliding mode control*

**Rosaidi Bin Roslan**

Department of Electrical Engineering, University Technology Malaysia

April 2009

International

*MPPT converter for photovoltaic application*

**R.Ramaprabha and B L Mathur**

International Journal of computer applications, (0975-8887), Vol 12-No.10,  
January 2011

International

*Intelligent controller based maximum power point tracking for solar PV system*

**M D Goudar, B P Patil and V Kumar**

978-1-4244-9189-6/11, 2011 IEEE, DOI:10.1109/ICDECOM.2011.5738551

International

*Adaptive MPPT algorithm for a distributed wireless photovoltaic based irrigation system*

**Kashif Ishaque, Zainal Salam, Hamed Taheri and Amir Shamsudin**

IEEE Applied power electronics colloquium (IAPEC, 978-1-4577-0008-8/11, 2011 IEEE

International

*Maximum power point tracking for PV system under partial shading condition via particle swarm optimization*

**R Ramaprabha and B L Mathur**

ARPN Journal of Engineering and Applied Sciences, Vol.7, No.6, June 2012

ISSN 1819-6608

International

*Application of intelligent control techniques for global maximum power point tracking of solar photovoltaic system*

**Aseem Sayal**

978-1-4673-0455-9/12, 2012 IEEE

International

*MPPT Techniques for photovoltaic system under uniform insolation and partial shading conditions*

**Abdullah Abdulaziz Al Yousef**

King Saud University College of Engineering, Electrical Engineering Department, 2008

International

*Fuzzy controller for maximum power point tracking*

**Chee Sing Lee**

Oregon State University, University Honors College, 2008

International

*Residential DC Distribution System with Photovoltaic Array Integration*

**Hannes Knopf**

Portland State University, 1999

International

*Analysis, simulation and evaluation of maximum power point tracking methods for a solar powered vehicle*

**Jaime Alonso – Martinez, Santiago Arnaltes**

Department of Electrical Engineering, Univ Carlos III de Madrid, Avda. Universidad 30,28911 Leganes (Madrid)

National

*Three phase grid connected inverter for Photovoltaic applications using Fuzzy MPPT*

**Neson Diaz, Johan Hernandez, Oscar Duarte**

Universidad Nacional, Division de Investigacion Bogota, LIFAE, Universidad Distrital, F.J.C. Colombia

National

*Fuzzy maximum power point tracking techniques applied to a grid-connected photovoltaic system*

**R Ramaprabha and B L Mathur**

International Journal of Advanced Engineering Technology, Vol III, Issue 1, 2012, E-ISSN 0976-3945

International

*A compact maximum power point tracking DC-DC Converter for solar photovoltaic system*

**S M Krishna Ganesh and L Muthuvel**

The International journal of computer Science and Applications (TIJCSA)  
Vol. 1, No.6, August 2012, ISSN 2278-1080

International

*FLC based Maximum power point tracking of solar photovoltaic system*

**Saad Mekhilef**

International Journal for Power Electronics, Vol 1, No. 1, 2008

International

*Performance of grid connected inverter with maximum power point tracker and power factor control*

**Steven L Brunton, Clarence W Rowley, Sanjeev R Kulkarni and Charles Clarkson**

National

*Maximum power point tracking for photovoltaic optimization using extremum seeking*

#### **D. Mathematical Modeling of SPV cell**

**Weixiang Shen, Yi Ding, Fook Hoong Choo Peng Wang, Poh Chiang Loh and Kuan Khoon Tan**

PEDS2009

National

*Mathematical model of a solar module for energy yield simulation in photovoltaic systems*

**Zsuzsa Preitl, Balazs Kulcsar and Jozse Bokor**

IEEE Intelligent vehicles symposium, 2008, 978-1-4244-2569-3/08 IEEE

International

*Piecewise linear parameter varying Mathematical model of a Hybrid Solar Vehicle*

**Mohamed Azab**

International Journal of Electrical and Engineering, 3:11 2009

International

*Improved Circuit Model of Photovoltaic Array*

**R Ramaprabha and B L Mathur**

Second International conference on Emerging Trends in Engineering and Technology

ICETET-09, 978-0-7695-3884-6/09, 2009 IEEE

International

*MATLAB based modeling to study the influence of shading on series connected SPVA*

**R Ramaprabha, B L Mathur and M Sharanya**

International conference on control, Automation, communication and Energy conservation (INCACEC'09)

International

*Solar array modeling and simulation of MPPT using neural network*

**Weixiang Shen, Yi Ding, Fook Hoong Choo, Peng Wang, Poh Chiang Loh and Kuan Khoon Tan**

PEDS2009

National

*Mathematical model of a solar module for energy yield simulation in photovoltaic systems*

**A Iqbal, H Abu-Rub and Sk M Ahmed**

2010 IEEE International Energy Conference, 978-1-4244-9380-7/10 IEEE

International

*Adaptive Neuro-Fuzzy inference system based maximum power point tracking of a Solar PV Module*

**Lin Phy Naing and Dipti Srinivasan**

978-1-4244-5721-2/10, 2010 IEEE

International

*Estimation of Solar power generating capacity*

**M Premkumar and S Ramachandran**

978-1-4244-9082-0/10, 2010 IEEE

International

*A Pilot model experimental setup and computational Fluid dynamics analysis of buoyancy driven solar engine*



**Suryanarayana Doolla and Rangan Banerjee**

978-1-4244-5892-9/10, 2010 IEEE

International

*Diffusion of Grid-connected PV in India: An analysis of variations in capacity factor*

**Wenyong Zhang, Maoyu Zheng and Xiao Wang**

Second International conference on computer modeling and simulation, 2010

978-0-7695-3941-6/10 IEEE, DOI:10.1109/ICCMS.2010.119

International

*Modeling and simulation of solar seasonal underground thermal storage in a solar-ground coupled heat pump system*

**Gao Lixin and Fang Xiumu**

Third International conference on Measuring technology and mechatronics

Automation, 2011, 978-0-7695-4296-6/11 IEEE, DOI : 10.1109/ICMTMA.

2011.464

International

*Numerical simulation of the Thermal Performance of Solar wall*

**R.Ramaprabha, Badrilal Mathur K.Santhosh and S.Sathyanarayanan**

International Journal of Emerging Trends in Engineering and Technology

(IJETET), Vol. I No. 1, 2011, ISSN 2248-9592

International

*Modeling and Simulation of SPVA Characterization under all Conditions*

**Shen Weixiang, Choo Fook Hoong, Wang Peng, Loh Poh Chiang and**

**Khoo Sui Yang**

978-1-4244-8756-1/11, 2011 IEEE

International

*Development of a mathematical model for solar module in Photovoltaic system*

**Suping Wu and Yahong zhang**

978-1-61284-774-0/11, 2011 IEEE

International

*The mathematical model for solar radiation penetration into double row greenhouse cucumber*

**Kon Chuen Kong, Mustafa bin Mamat, Mohd. Zamri Ibrahim and Abdul Majeed Muzathik**

Applied Mathematical Sciences, Vol. 6, 2012

National

*New Approach on Mathematical Modeling of Photovoltaic Solar Panel*

**Arman B Mirmanov and Yuri D Kozliaev**

6<sup>th</sup> International Siberian workshop and tutorial EDM'2005, Session IV, July 1-5, ERLAGOL, ISSN 1815-3712, ISBN 5-7782-0491-4

International

*Mathematical models of signals forming in inverters with the method of pulse width modulation*

**Ebrahim M Ali Alfegi, Kamaruzzaman Sopian, Mohd Yusof Hj Othman and Baharudin Bin Yatim**

ARPN Journal of Engineering and Applied Sciences, Vol.2, No.5, Oct 2007

ISSN 1819-6608

International

*Transient mathematical model of both side single pass photovoltaic thermal air collector*

**Huan-Liang Tsai, Ci-Siang Tu, and Yi-Jie Su**

Proceedings of the World Congress on Engineering and Computer Science 2008, WCECS 2008, October 2008, San Francisco, USA, ISBN: 978-988-98671-0-2

International

*Development of generalized photovoltaic model using MATLAB/SIMULINK*

**Pothina Karthik, Harish Sesham and Dr P N Hrisheekesha**

IEEE – International conference on Advances in Engineering, Science and Management (ICAESM-2012), March 30-31, 2012, ISBN:978-81-909042-2-3

IEEE

International

*Simulation and Performance analysis of renewable based standalone system for smart mini Grid applications*

**M Mahalakshmi, S Latha**

International Journal of engineering Science and Technology (IJEST), Vol. 4, No.5, May 2012, ISSN: 0975-5462

International

*Modeling, Simulation and sizing of photovoltaic/wind /fuel cell hybrid generation system*

**Shah Arifur Rahman and Rajiv K Varma**

University of Western Ontario, Canada

International

*PSCAD/EMTDC model of a 3 phase grid connected photovoltaic solar system*

### **E. Mathematical Modeling of Inverter**

**Fred Berry**

Southeastcon 1989 – Proceedings, CH2674-5/89/0000-0455 IEEE

International

*Steady state mathematical model for the DC-AC inverters on the space shuttle*

**T Stefanski**

Kielce University of Technology, IEEE Catalog Number: 97TH8280, ISIE'97-Guimaraes, Portugal

International

*Mathematical model of inverter-fed induction motor drive for adaptive control with “Gain scheduling”*

**Siriwich Tadsuan and Chanwit Tangsiriworakul**

978-1-4244-1706-3/08, 2008 IEEE

International

*Design and comparison of iron losses mathematical model with single phase and three phase PWM inverter supply*

**Ahmed H Eltom and Aliosman Demirbas**

978-1-4244-4252-2/09, 2009 IEEE

International

*Motor System Energy efficiency in the Nylon industry: A comparison of PWM and square wave inverters*

**Jawad Faiz and Ghazanfar Shahgholian**

Armenian Journal of Physics, 2009, vol. 2, issue 4, pp. 307-316

International

*Modeling and simulation of a three-phase inverter with rectifier-type nonlinear loads*

**Kun Yu, Fang-Lin Luo and Miao Zhu**

978-1-4244-5046-6/10, 2010 IEEE

International

*Study of an Improved Z-Source Inverter: Small Signal Analysis*

**Yi Ding, Poh Chiang Loh, Kuan Khoon Tan, Peng Wang and Feng Gao**

978-1-4244-4783-1/10, 2010 IEEE

International

*Reliability evaluation of Three-Level Inverters*

**F Genduso and R Miceli**

2011 IEEE International Electric Machines and Drives conference (IEMDC)

978-1-4577-0061-3/11, 2011 IEEE

International

*Mathematical model for non-redundant fault-tolerant inverters*

**Kun Mu, Xiaoyu Ma, Xiaobin Mu and Dalei Zhu**

2011 International Conference on Electronic and Mechanical Engineering and Information Technology, 978-1-61284-088-8/11, 2011 IEEE

International

*Nonlinear control strategy for three-phase photovoltaic Grid-connected Inverter*

**Xu Peng Fang, Yan Chao Tan, Ming Jie Zhu, Mao Yong Cao**

IEEE International Conference on Applied Superconductivity and Electromagnetic Devices Sydney, Australia, December 14-16, 2011, 978-1-4244-7853-8/11, 2011 IEEE

International

*The control strategy of current-Fed Z-source inverter in wind power grid*

**Yunya Wu, Ning Li, Zhilei Yao, Yingcheng Xue and Dongchun Wu**

IEEE 7<sup>th</sup> International Power Electronics and Motion control conference – ECCE Asia, June 2-5, 2012, Harbin, China, 978-1-4577-2088-8/11, 2012 IEEE

International

*Control strategy based on double coordinates for Three-Phase Grid-connected inverters*

**Zhu Dan, Wang Tong, Wang Zhi, Sun Zu Yong and Guo Liang**

2011 The International Conference on Advanced Power system Automation and Protection, 978-1-4244-9621-1/11, 2011 IEEE

International

*Advanced control method of inverters in Microgrid*

**Arman B Mirmanov and Yuri D Kozliaev**

6<sup>th</sup> International Siberian workshop and tutorial EDM' 2005, Session IV, July 1-5, Erlagol

ISSN 1815-3712, ISBN 5-7782-0491-4, DOI:10.1109/SIBEDM. 2005. 195630

International

*Mathematical models of signals forming in inverters with the method of pulse width modulation*

**Soeren Baekhoej Kjaer, John K Pedersen, Frede Blaabjerg**

IEEE Transactions on Industry Applications, Vol. 41, No. 5, Sep/Oct 2005

International

*Single-Phase Grid-Connected Inverters for Photovoltaic Modules*

**Darko D Vracar and Slobodan N Vukosavic**

Serbia and Montenegro, Belgrade, November 22-24, 2005, 1-4244-0049-X/05

IEEE

International

*Resonant DC link inverter: Mathematical modeling and computer simulations*

**B R Lin, H K Chiang and C H Huang**

IEE Proc-Electr, Power Appl, Vol 153. No.4, July 2006, DOI: 10.1049/ip-

epa:20050363

International

*Three phase three-level active power filter with a clamped capacitor topology*

**Feng Tian, Siri Kasemsan and Issa Batarseh**

IEEE Transactions on Power Electronics, Vol.26, No.10, Oct. 2011

0885-8993 IEEE, DOI:10.1109/TPEN.2009.2022297

International

*An adaptive slope compensation for the single-stage inverter with peak current-mode control*

**B S Cunha, J R Camach and C A Bissochi**

2001 IEEE Porto Power Tech Conference, 0-7803-7139-9/01 IEEE

International

*Single-phase induction motor speed control through a PIC controlled sinusoidal PWM inverter-The mathematical model and various load conditions*

**H Biechl, H W Lorenzen and D Potoradi**

Laboratory of Electrical drives and automation, Fachhochschule Kempten-

Nen-Ulm, University of Applied sciences, Germany

National

*Mathematical modeling, simulation and optimization of an asynchronous exciter for inverter-fed synchronous machines*

**R. Teodorescu, F. Blaabjerg, U. Borup, M. Liserre**

Institute of Energy Technology, 0-7803-8269-2/04 IEEE

International

*A new control structure for grid-connected LCL PV inverters with zero steady-state error and selective harmonic compensation*

**Xiaobin Mu, Jiuhe Wang, Hao Xiang, Yuling Ma and Dongying Yang**

School of Automation, Beijing Information Science and Technology University, Beijing, China

National

*Nonlinear control strategy for three-phase voltage sources PWM DC/AC Inverter based on PCH Model*

**Zhongni Zhu, Yuandi Chen, Rong Wang and Hua Zhong**

University of Science and Technology, Wuhan, China

National

*Research on the Symmetrical four-phase voltage produced by the three-phase four-bridge inverter*

## **F. Micro Grid Control**

**N Hamrouni and A Cherif**

*Revue des Energies Recouvelables, Vol.10, 335-344, 2007*

National

Modeling and control of a grid connected photovoltaic system

**Y Zhou, J A Ferreira and P Bauer**

IEEE PES Power Africa 2007 Conference and Exposition, 1-4244-1478-4/07

IEEE

International

*Grid connected and islanded operation of a hybrid power system*

**Denizar C Martins and Kleber C A De Souza**

International Journal of circuits, systems and signal processing, Issue 1, Vol 2,  
2008

International

*A single-phase Grid-connected PV system with Active power filter*

**Cai Tao, Duan Shanxu and Chen Changsong**

2<sup>nd</sup> IEEE International Symposium on Power Electronics for Distributed  
Generation System, 2010, 978-1-4244-5670-3/10 IEEE

International

*Forecasting power output for Grid-connected PC power system without using  
Solar Radiation measurement*

**Mateus F Schonardie, Adriano Ruseler, Roberto F Coelho and Denizar C  
Martins**

9<sup>th</sup> IEEE/IAS International Conference on Industry Applications –  
INDUSCON 2010, 978-1-4244-8010-4/10 IEEE

International

*Three phase grid connected PV system with active and reactive power control  
using dq0 transformation*

**Yuanrui Chen and Jie Wu**

Electric Power College, South China University of Technology, Fuanzhou,  
China

National

*Agent based energy management and control of a grid connected wind/solar  
hybrid power system*

**Li-Shiang Lai, Wen-Chieh Hou, Ya-Tsung Feng and Yu-An Chen**

DRPT 2008 6-9 April 2008, 978-7-900714-13-8/08 IEEE

International

*Novel Grid connected Photovoltaic Generation system*

**Li Wang and Chen-Bin Huang**

IEEE Transactions on sustainable Energy



Vol.1, No.1, April 2010, DOI:10.1109/TSTE.2010.2046189

International

*Dynamic stability analysis of a grid connected solar-concentrated ocean thermal energy conversion system*

**F Bouchafaa, D Beriber and M S Boucherit**

18<sup>th</sup> Mediterranean Conference on Control and Automation, June 2010, 978-1-4244-8092-0/10 IEEE

International

*Modeling and control of a grid connected PV generation system*

**A Muntasib Chowdhury, I Alam, M Rahman, T Rahman Khan, T Baidya, A Hasib Chowdhury**

6<sup>th</sup> International Conference on Electrical and Computer Engineering, ICECE 2010, December 2010, 978-1-4244-6279-7/10 IEEE

International

*Design and cost benefit analysis of grid connected solar PV system for the AUST campus*

**Luke D Watson, Jonathan W Kimball**

Missouri University of Science and Technology, Rolla, MO, USA, 978-1-4244-8085-2/11 IEEE

International

*Frequency regulation of a microgrid using solar power*

**Mohamed Amer Chaaban**

University of Nebraska Lincoln, May 2011

International

*Adaptive photovoltaic configurations for decreasing the electrical mismatching losses*

**Prakash K Ray, Vijay P Singh, Soumya R Mohanty, Nand Kishor and Sumit Sen**

The 5<sup>th</sup> International Power Engineering and Optimization Conference (PEOCO2011), Malaysia, June 2011

978-1-4577-0354-6/11 IEEE

International

*Frequency control based on  $H_\infty$  controller for small hybrid power system*

**Amal A Hassan, Faten H Fahmy, ABD El-Shafy A Nafeh and Mohamed A Elsayed**

WSEAS Transactions on systems and control

Issue 1, Vol 5, Jan 2010, ISSN : 1991-8763

International

*Modeling and simulation of a single phase grid connected photovoltaic system*

**Fei Ding, Peng Li, Bibin Huang, Fei Gao, Chengdi Ding and Chengshan Wang**

China International conference on Electricity Distribution, 2010

International

*Modeling and simulation of Grid-connected hybrid PV/battery distributed generation system*

**Indranil Bhattacharya, Yuhang Deng and Simon Y Foo**

2<sup>nd</sup> Asia Symposium on Quality Electronic Design

978-1-4244-7808-8/10 IEEE

International

*Active Filters for harmonic elimination in solar PV Grid-connected and stand-alone systems*

**Leo C K Liao and LEE-Ching Kuo**

0-7803-5772-8/00, 2000 IEEE

International

*Power generation mechanism of a grid-connected PV system*

**Liming Liu, Yan Zhou and Hui Li**

Florida State University, Tallahassee, USA

978-1-4244-5287-3/10 IEEE

International

*Co-ordinated active and reactive power management implementation based on dual-stage PLL method for Grid-connected PV system with battery*

**Luke D Watson and Jonathan W Kimball**

ISBN: 978-1-4244-8084-5

DOI:10.1109/APEC.2011.5744615

International

*Frequency regulation of a Microgrid using Solar Power*

**Rafael K Jordan, Istvan Nagy and Robert Barabas**

0-7803-7852-0/03 IEEE

International

*Control of a combined photovoltaic/ Thermal energy system*

**Rajiv K Varma, Shah Arifur Rahman and Ravi Seethapathy**

IEEE

International

*Novel Control of Grid Connected Photovoltaic Solar Farm for Improving Transient Stability and Transmission Limits Both During Night and Day*

**T Alquthami, H Ravindra, M O Faruque and T Baldwin**

IEEE

National

*Study of PV integration impact on system stability using custom model of PV arrays integrated with PSS/E*

**Yaosuo Xue, Madhav Manjrekar, Chenxi Lin, Maria Tamayo and John N Jiang**

978-1-4577-1002-5/11 IEEE

International

*Voltage stability and sensitivity analysis of grid connected Photovoltaic systems*

### **G. Partial Shading improvements in SPV**

**Y J Wang and P C Hsu**

IET Renewable Power Generation, Vol. 4, Issue 3, 272-282, 2010

DOI: 10.1049/iet-rpg. 2009.0157

ISSN 1752-1416

International

*Analytical modeling of partial shading and different orientation of PV modules*

**R.Ramaprabha and B.L.Mathur**

European Journal of Scientific Research, ISSN 1450-216X Vol.47 No.1, 2010,  
pp.122-134 November 2012

International

*Development of an Improved Model of SPV Cell for Partially Shaded Solar Photovoltaic Arrays*

**R Ramaprabha and B L Mathur**

Hindawi Publishing Corporation, International Journal of Photoenergy, Vol  
2012, Article ID 120214

Doi: 10.1155/2012/120214

International

*A comprehensive review and analysis of solar photovoltaic array configurations under partial shaded conditions*

**Lijun Gao, Roger A Dougal, Shengyi Liu, Albena P Iotova**

IEEE Transactions on Industrial Electronics, Vol.56, No.5, May 2009

DOI:10.1109/TIE.2008.2011296, 0278-0046 IEEE

International

*Parallel-connected solar PV System to address partial and rapidly fluctuating shadow conditions*

**Chris Deline**

978-1-4244-2950-9/09, 2009 IEEE

International

*Partially shaded operation of a Grid-Tied PV System*

**Young-Hyok Ji, Doo-Yong Jung, Chung-Yuen Won, Byoung-Kuk Lee,  
Jin-Wook Kim**

978-1-4244-2893-9/09, 2009 IEEE

International

*Maximum power point tracking method for PV array under partially shaded condition*

**R Ramaprabha and B L Mathur**

International Journal of Recent Trends in Engineering

Vol 2, No.7, November 2009

International

*Impact of partial shading on solar PV module containing series connected cells*

**Niket Thakkar, Daniel Cormode, Vincent P.A. Lonij, Steve Pulver and Alexander D. Cronin**

Feb. 11, 2010

National

*A Simple Nonlinear Model for the Effect of Partial Shade on PV Systems*

**Ali S Masoum, Frank Padovan, Mohammad A S Masoum**

978-1-4244-6551-4/10, 2010 IEEE

International

*Impact of partial shading on voltage and current based maximum power point tracking of solar modules*

**Chris Deline**

978-1-4244-5892-9/10, 2010 IEEE

International

*Partially shaded operation of multi-string photovoltaic systems*

**Ankit Gupta, Anuja bagul, Bhushan Kadu**

Maharashtra Institute of Technology and Advanced Robotics Research organization

National

*Increasing efficiency of the photovoltaic system of mobile robotic platforms for military application and exploration*

**Mohammed Abdulazeez, Ires Iskender**

Gazi University, Ankara, Turkey

National

*Simulation and experimental study of shading effect on series and parallel connected photovoltaic PV modules*

#### **H. SPV Array re-configuration strategy**

**R.Ramaprabha and Dr.B.L.Mathur**

International Review on Modelling and Simulations, June 2010

International

*Comparative Study of Series and Parallel configurations of Solar PV Array under Partial Shaded Conditions*

**B Patnaik, P Sharma, E Trimurthulu, S P Duttagupta, V Agarwal**

978-1-4244-9965-6/11, 2011 IEEE

International

*Reconfiguration strategy for optimization of SPV array under non uniform illumination conditions*

**B Patnaik, J D Mohod, S P Duttagupta**

IIT Bombay, India

National

*Distributed multi-sensor network for real time monitoring of illumination states for a reconfigurable SPV array*

## **APPENDIX 1**

Underwriters Laboratories has prepared UL 1741-1999 specifically for PV inverters and PV charge controllers. The utility interconnection testing in UL 1741-1999 contains tests to confirm that an inverter meets the power quality recommendations of Clause 4 of this recommended practice.

#### **4.1 Normal voltage operating range**

Utility-interconnected PV systems do not regulate voltage, they inject current into the utility. Therefore, the voltage operating range for PV inverters is selected as a protection function that responds to abnormal utility conditions, not as a voltage regulation function.

Clearly, a large quantity of this current injection has the potential for impacting utility voltage. As long as the magnitude of PV current injection on a utility line remains less than the load on that line, the utility's voltage regulation devices will continue to operate normally. If the PV current injection on a utility line exceeds the load on that line, then corrective action is required, as the voltage regulation devices do not normally have directional current sensing capability.

See 5.1.1 for recommended device response when voltage at the PCC lies outside the specified operating range.

##### **4.1.1 Small systems ( $\leq 10$ kW)**

Small PV systems should be capable of operating within the limits normally experienced on utility distribution lines. It is in the best interest of both the interconnected utility and the PV system owner that the operating window be selected in a manner that minimizes nuisance tripping. The operating window for these small PV systems is 106–132 V on a 120 V base, that is, 88–110% of nominal voltage. This range results in trip points at 105 V and at 133 V.

In actual practice, the 133 V trip point is related to the PCC voltage, which is not necessarily the inverter terminal voltage. If the inverter installation is electrically near enough to the PCC to allow negligible voltage difference between the inverter and the PCC, then the 133 V trip point will apply to the inverter terminals as well as the PCC. However, some systems may have installation restrictions that do not allow negligible voltage difference between the inverter and the PCC. In such cases, the techniques described in B.9 may be useful in allowing for this voltage difference.

The recommendation of this clause is that the inverter cease to energize the utility lines whenever the voltage at the PCC deviates from the allowable voltage operating range of 106–132 V.

##### **4.1.2 Intermediate and large systems**

Utilities may have specific operating voltage ranges for intermediate and large PV systems and may require adjustable operating voltage settings for these larger systems. In the absence of such requirements, the principles of operating between 88% and 110% of the appropriate interconnection voltage (see 4.1.1) should be followed.

#### **4.2 Voltage flicker**

Whether a particular amount and frequency of voltage flicker are problems is highly subjective. The topic has been documented in several studies in the past, including one by the New England Electric Power Service Co. [B10], and is discussed in 10.5 of IEEE Std 519-1992, particularly Figure 10.3. Any voltage flicker resulting from the connection of the inverter to the utility system at the PCC should not exceed the limits defined by the maximum borderline of irritation curve identified in IEEE Std 519-1992. This requirement is necessary to minimize the adverse voltage effects to other customers on the utility system.



### 4.3 Frequency

The utility controls system frequency, and the PV system shall operate in synchronism with the utility. Small PV systems installed in North America should have a fixed operating frequency range of 59.3–60.5 Hz. Systems installed in another country should follow the frequency operating window standards of that country. Small isolated utility systems, as are often encountered on islands and in remote areas, may require larger frequency windows for small systems because of prevalent frequency deviations outside the above-specified window. Utilities may require adjustable operating frequency settings for intermediate and large systems.

See 5.1.2 for action recommended when frequency at the PCC lies outside the specified operating range.

### 4.4 Waveform distortion

The PV system output should have low current-distortion levels to ensure that no adverse effects are caused to other equipment connected to the utility system. The PV system electrical output at the PCC should comply with Clause 10 of IEEE Std 519-1992 and should be used to define the acceptable distortion levels for PV systems connected to a utility. The key requirements of this clause are summarized in the following:

- Total harmonic current distortion shall be less than 5% of the fundamental frequency current at rated inverter output.
- Each individual harmonic shall be limited to the percentages listed in Table 1. The limits in Table 1 are a percentage of the fundamental frequency current at full system output. Even harmonics in these ranges shall be <25% of the odd harmonic limits listed.

**Table 1—Distortion limits as recommended in IEEE Std 519-1992 for six-pulse converters**

Odd harmonics	Distortion limit
3 <sup>rd</sup> –9 <sup>th</sup>	< 4.0%
11 <sup>th</sup> –15 <sup>th</sup>	< 2.0%
17 <sup>th</sup> –21 <sup>st</sup>	< 1.5%
23 <sup>rd</sup> –33 <sup>rd</sup>	< 0.6%
Above the 33 <sup>rd</sup>	< 0.3%

These requirements are for six-pulse converters and general distortion situations. IEEE Std 519-1992 gives a conversion formula for converters with pulse numbers greater than six.

### 4.5 Power factor

The PV system should operate at a power factor > 0.85 (lagging or leading) when output is > 10% of rating. Most PV inverters designed for utility-interconnected service operate close to unity power factor. Specially designed systems that provide reactive power compensation may operate outside of this limit with utility approval.

For small systems, the above setpoints should be nonuser-adjustable.

For intermediate and large PV systems, the voltage setpoints may be field adjustable if approved by the interconnecting utility. For intermediate and large PV systems being fed from medium-voltage switchgear, consideration should be given to monitoring voltage for the recommendations of this subclause at the PCC in order to avoid problems with voltage drop in various transformers, wiring, or feeder circuits.

### 5.1.2 Frequency disturbances

As discussed in 4.3, small PV systems should have a fixed frequency operating range of 59.3–60.5 Hz. The test points for determining proper operation of the frequency trip function should be 59.2 Hz and 60.6 Hz. For intermediate and large systems, utilities may require the ability to adjust the operating frequency range for special circumstances.

When the utility frequency is outside the range of 59.3–60.5 Hz, the inverter should cease to energize the utility line within six cycles. The purpose of the allowed time delay is to ride through short-term disturbances to avoid excessive nuisance tripping.

### 5.1.3 Islanding protection

This subclause addresses anti-islanding features required of the PV inverter to ensure that the inverter ceases to energize the utility line when the inverter is subjected to islanding conditions. For a discussion of islanding as it applies to PV systems, see Kern et al. [B4]; Stevens et al. [B12]; Begovic et al. [B1]; and Annex D.

PV systems are protected against the vast majority of potential islanding situations by voltage and frequency detection schemes as discussed in 5.1.1 and 5.1.2. However, it is possible that circumstances may exist on a line section that has been isolated from the utility and contains a balance of load and PV generation that would allow continued operation of PV systems (see Begovic et al. [B1] and Annex E). Such circumstances would require a load-to-generation balance so that both frequency and voltage remain inside the trip limits described in 5.1.1 and 5.1.2. Although such a load balance is perceived as a low-probability event, the potential impact of such an occurrence is great enough that this distributed resource islanding has been the subject of numerous studies and much research (Kern [B3]; New England Electric Power Service Co. [B10]; Stevens [B11]; Kern et al. [B4]; Stevens et al. [B12]; and Begovich et al. [B1]). This work has resulted in development of active control techniques that have proven to be reliable in detecting potential distributed resource islands, as well as a method to determine whether an adequate anti-islanding scheme is operational in an inverter. (See Annex A and Annex D.)

A utility wishing to ensure against establishment of a PV-supported distributed resource island should require the use of a nonislanding inverter. See 3.2 for the definition of a nonislanding inverter.

Another factor that works in favor of nonsupport of a distributed resource island by PV systems is the inability of most PV inverters designed for utility interconnection to supply the demand distortion or nonunity power factor associated with nonlinear loads. An instructive example is presented in Stevens et al. [B12] and briefly described in Annex D.

### 5.1.4 Reconnect after a utility disturbance

Following an out-of-bounds utility event that has caused the PV system to cease to energize the utility line, line energization should remain disabled until continuous normal voltage and frequency (that is, voltage and frequency within the limits described in 4.1 and 4.3) have been maintained by the utility for a minimum of 5 min, at which time the inverter is allowed to automatically reconnect the PV system to the utility.

factor that is very near unity. Some inverter manufacturers provide optional power factor control capability that allows the user to set either a constant power factor or constant reactive power delivery by the inverter.

At very low power levels (< 10% of inverter rated capacity), inverters designed to operate at unity power factor at full load may operate at a nonunity power factor due to inverter components (e.g., output filters, transformers) that appear as small, fixed reactive loads. Even though the power factor may drop below unity at these low power levels, however, the reactive demand on the utility is no greater than it is at full inverter output.

## **B.7 DC injection**

Inverter manufacturers generally use one of two methods to prevent the injection of dc current into the utility interface. One method is to incorporate an ac output isolation transformer in the inverter. The other method, which uses a shunt or dc-current sensor, initiates inverter shutdown when the dc component of the current exceeds the specified threshold.

## **B.8 Soft starting**

Modern PV inverters with peak-power-tracking capability often employ soft starting. Upon restoration of the utility voltage and the appropriate time delay of 5 min, the peak-power-tracking algorithm in the inverter will ramp the output current over time to bring the array from open-circuit voltage (that is, zero current) to its peak power-point voltage.

## **B.9 Line-drop voltage offset**

Service voltage of the PV system is discussed in 4.1. On PV systems where the inverter is mounted remotely from the PCC, as rooftop PV systems often are, it is possible that a voltage difference will exist between the inverter terminals and the PCC. Since the voltage at the PCC is the parameter that should be maintained within specified limits, the inverter may have some means of compensating for this voltage difference. Inverter manufacturers may take any of several approaches, including switches in the inverter (either hardware or software) that add amounts of voltage to the trip setting, as determined by the maximum voltage drop possible with the particular installation. For example, if it is calculated that a 2 V difference will exist in the wiring between the inverter and the PCC at maximum PV output, then the switch is set at +2 V. Another approach is to have the inverter calculate the voltage difference, then add it to the trip setting. In keeping with the practices required in the NEC, the installation should be designed in a manner that the voltage difference between the inverter and the PCC does not exceed 3% for branch circuits and 5% for feeder circuits.

## **B.10 Controls integrated into the inverter**

The integration of protection and controls into the inverter itself, as opposed to utilizing separate, discrete protective devices, is being pursued as both a cost-reduction measure and as a means of increasing the reliability of the protection system. With this integration, any failures of protection or control features will result in an inoperative inverter, rather than an inverter that continues to operate without protection.

## **APPENDIX 2**

## PHOTOVOLTAIC (PV) SYSTEMS – CHARACTERISTICS OF THE UTILITY INTERFACE

### 1 Scope and object

This International Standard applies to utility-interconnected photovoltaic (PV) power systems operating in parallel with the utility and utilizing static (solid-state) non-islanding inverters for the conversion of DC to AC. This document describes specific recommendations for systems rated at 10 kVA or less, such as may be utilized on individual residences single or three phase. This standard applies to interconnection with the low-voltage utility distribution system.

The object of this standard is to lay down requirements for interconnection of PV systems to the utility distribution system.

NOTE 1 An inverter with type certification meeting the standards as detailed in this standard should be deemed acceptable for installation without any further testing.

This standard does not deal with EMC or protection mechanisms against islanding.

NOTE 2 Interface requirements may vary when storage systems are incorporated or when control signals for PV system operation are supplied by the utility.

### 2 Normative references

The following referenced documents are indispensable for the application of this document. For dated references, only the edition cited applies. For undated references, the latest edition of the referenced document (including any amendments) applies.

IEC 60364-7-712:2002, *Electrical installations of buildings – Part 7-712: Requirements for special installations or locations – Solar photovoltaic (PV) power supply systems*

IEC 61000-3-3:1994, *Electromagnetic compatibility (EMC) – Part 3-3: Limits – Limitation of voltage changes, voltage fluctuations and flicker in public low-voltage supply systems, for equipment with rated current  $\leq 16$  A per phase and not subject to conditional connection*<sup>1</sup>

IEC 61000-3-5:1994, *Electromagnetic compatibility (EMC) – Part 3: Limits – Section 5: Limitation of voltage fluctuations and flicker in low-voltage power supply systems for equipment with rated current greater than 16 A*

IEC 61277:1995, *Terrestrial photovoltaic (PV) power generating systems – General and guide*

IEC 61836:1997, *Solar photovoltaic energy systems – Terms and symbols*

<sup>1</sup> A consolidated edition 1.1 (2002) which includes amendment 1 (2001) exists.

### 4.3 Flicker

The operation of the PV system should not cause voltage flicker in excess of limits stated in the relevant sections of IEC 61000-3-3 for systems less than 16 A or IEC 61000-3-5 for systems with current of 16 A and above.

### 4.4 DC injection

The PV system shall not inject DC current greater than 1 % of the rated inverter output current, into the utility AC interface under any operating condition.

### 4.5 Normal frequency operating range

The PV system shall operate in synchronism with the utility system, and within the frequency trip limits defined in 5.2.2.

### 4.6 Harmonics and waveform distortion

Low levels of current and voltage harmonics are desirable; the higher harmonic levels increase the potential for adverse effects on connected equipment.

Acceptable levels of harmonic voltage and current depend upon distribution system characteristics, type of service, connected loads/apparatus, and established utility practice.

The PV system output should have low current-distortion levels to ensure that no adverse effects are caused to other equipment connected to the utility system.

Total harmonic current distortion shall be less than 5 % at rated inverter output. Each individual harmonic shall be limited to the percentages listed in Table 1.

Even harmonics in these ranges shall be less than 25 % of the lower odd harmonic limits listed.

**Table 1 – Current distortion limits**

Odd harmonics	Distortion limit
3 <sup>rd</sup> through 9 <sup>th</sup>	Less than 4,0 %
11 <sup>th</sup> through 15 <sup>th</sup>	Less than 2,0 %
17 <sup>th</sup> through 21 <sup>st</sup>	Less than 1,5 %
23 <sup>rd</sup> through 33 <sup>rd</sup>	Less than 0,6 %

Even harmonics	Distortion limit
2 <sup>nd</sup> through 8 <sup>th</sup>	Less than 1,0 %
10 <sup>th</sup> through 32 <sup>nd</sup>	Less than 0,5 %

NOTE Testing harmonics is very problematic, since voltage distortion may lead to enhanced current distortion. The harmonic current injection should be exclusive of any harmonic currents due to harmonic voltage distortion present in the utility grid without the PV system connected. Type tested inverters meeting the above requirements should be deemed to comply without further testing.

## **APPENDIX 3**

### 8.3.2.3 Tips, techniques, and rules of thumb

Historically, voltage that caused flicker was measured with fast time-constant rms meters, load duty cycles, and a strip chart or similar recorder. Recently, a flickermeter that gives a much more quantitative measure of the likelihood of flicker problems has been developed. In the highly specialized field of power quality analysis, techniques have evolved to estimate the margin that might be available in any given system before flicker would be a problem. Of course, flicker measurements can always be taken after the DR has been installed, but if a problem is discovered, the DR unit has to be shut off or limited in operation until a distribution system reinforcement can be installed.

The IEC has comprehensive standards for assessing flicker levels on area EPSs. These standards take into account complex disturbances and multiple sources. For example, IEC/TR 61000-3-7:2008 [B18] provides detailed explanation and calculation methods for determining if any type of voltage change can cause objectionable flicker. All major wind turbine manufacturers publish data that can be used with this standard to predict flicker levels at any location on the area EPS. The flickermeter and these computational techniques can produce an acceptable measure of Pst severity, denoted as the Pst level.

Using this technique, flicker produced by a DR will be acceptable under the IEC standard if the Pst severity is less than or equal to 1 for a PCC at the secondary distribution voltage or less than or equal to 0.9 for a PCC at the primary distribution voltage—both with 99% compliance (on a one-week basis). Higher flicker levels may be allowed at the discretion of the area EPS operator.

DR units will meet the IEC requirement if the power variations from the unit ( $\Delta S$ ) compared with the available short-circuit capacity (SSC) of the area EPS at the PCC are within the limits described in Table 9.

**Table 9—Acceptable voltage changes as a function of  $(\Delta S/SSC)_{max}$**

Voltage changes per minute ( r )	$(\Delta S/SSC)_{max}$ (%)
$r > 200$	0.15
$10 \leq r \leq 200$	0.23
$r < 10$	0.46

See Annex B for a discussion of DR characteristics that may produce voltage deviations in the flicker frequency range.

### 8.3.3 Harmonics (IEEE Std 1547-2003 4.3.3)

**“When the DR is serving balanced linear loads, harmonic current injection into the Area EPS at the PCC shall not exceed the limits stated below in [Table 10]. The harmonic current injections shall be exclusive of any harmonic currents due to harmonic voltage distortion present in the Area EPS without the DR connected.**



**Table 10—Maximum harmonic current distortion in percent of current (I) <sup>a</sup>**

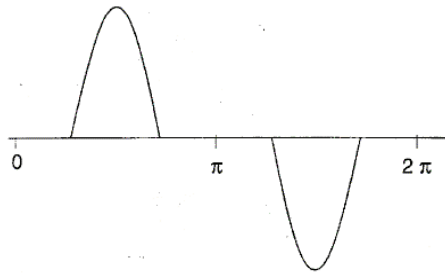
Individual harmonic order (odd harmonics) <sup>b</sup>	$h < 11$	$11 \leq h < 17$	$17 \leq h < 23$	$23 \leq h < 35$	$35 \leq h$	Total demand distortion
Percent (%)	4.0	2.0	1.5	0.6	0.3	5.0

<sup>a</sup> I = The greater of the local EPS maximum load current integrated demand (15 min or 30 min) without the DR unit or the DR unit rated current capacity (transformed to the PCC when a transformer exists between the DR unit and the PCC).

<sup>b</sup> Even harmonics are limited to 25% of the odd harmonic limits shown.

### 8.3.3.1 Background

Harmonic distortion is a form of electrical noise; harmonics are electrical signals at multiple frequencies of the power line frequency. Many electronic devices—including personal computers, adjustable speed drives, and other types of equipment that use just part of the sine wave by drawing current in short pulses (as shown in Figure 11)—cause harmonics.



**Figure 11—Wave of switched-mode power supply**

Linear loads, those that draw current in direct proportion to the voltage applied, do not generate large levels of harmonics. The nonlinear load of a switched power supply superimposes signals at multiples of the fundamental power frequency in the power sine wave and creates harmonics. The nonlinear loads connected to area EPSs include static power converters, arc discharge devices, saturated magnetic devices, and, to a lesser degree, rotating machines. Static power converters of electric power are the largest nonlinear loads. Harmonic currents cause transformers to overheat, which, in turn, overheat neutral conductors. This overheating may cause erroneous tripping of circuit breakers and other equipment malfunctions. The voltage distortion created by nonlinear loads may create voltage distortion beyond the premise’s wiring system, through the area EPS, to another user.<sup>36</sup>

This IEEE 1547 requirement applies to voltages from 120 V to 69 kV and is drawn directly from IEEE Std 519-1992 [B29].<sup>37</sup> IEEE Std 519-1992 is based on the premises that the harmonic distortion

<sup>36</sup>When reactive power compensation, in the form of power factor improvement capacitors, is used with these nonlinear loads, resonant conditions can occur that may result in high levels of harmonic voltage and current distortion when the resonant condition occurs at a harmonic associated with nonlinear loads.

<sup>37</sup>The limits listed in Table 10 are the same as those presented in IEEE Std 519-1992 [B29]. These should be used as system design values for the worst case for normal operation (conditions that last longer than 1 h). For shorter periods, during startups or unusual conditions, the limits may be exceeded by 50%.

## **APPENDIX 4**

**IEEE Standards** documents are developed within the IEEE Societies and the Standards Coordinating Committees of the IEEE Standards Association (IEEE-SA) Standards Board. The IEEE develops its standards through a consensus development process, approved by the American National Standards Institute, which brings together volunteers representing varied viewpoints and interests to achieve the final product. Volunteers are not necessarily members of the Institute and serve without compensation. While the IEEE administers the process and establishes rules to promote fairness in the consensus development process, the IEEE does not independently evaluate, test, or verify the accuracy of any of the information or the soundness of any judgments contained in its standards.

Use of an IEEE Standard is wholly voluntary. The IEEE disclaims liability for any personal injury, property or other damage, of any nature whatsoever, whether special, indirect, consequential, or compensatory, directly or indirectly resulting from the publication, use of, or reliance upon this, or any other IEEE Standard document.

The IEEE does not warrant or represent the accuracy or content of the material contained herein, and expressly disclaims any express or implied warranty, including any implied warranty of merchantability or fitness for a specific purpose, or that the use of the material contained herein is free from patent infringement. IEEE Standards documents are supplied “**AS IS.**”

The existence of an IEEE Standard does not imply that there are no other ways to produce, test, measure, purchase, market, or provide other goods and services related to the scope of the IEEE Standard. Furthermore, the viewpoint expressed at the time a standard is approved and issued is subject to change brought about through developments in the state of the art and comments received from users of the standard. Every IEEE Standard is subjected to review at least every five years for revision or reaffirmation. When a document is more than five years old and has not been reaffirmed, it is reasonable to conclude that its contents, although still of some value, do not wholly reflect the present state of the art. Users are cautioned to check to determine that they have the latest edition of any IEEE Standard.

In publishing and making this document available, the IEEE is not suggesting or rendering professional or other services for, or on behalf of, any person or entity. Nor is the IEEE undertaking to perform any duty owed by any other person or entity to another. Any person utilizing this, and any other IEEE Standards document, should rely upon his or her independent judgment in the exercise of reasonable care in any given circumstances or, as appropriate, seek the advice of a competent professional in determining the appropriateness of a given IEEE standard.

**Interpretations:** Occasionally questions may arise regarding the meaning of portions of standards as they relate to specific applications. When the need for interpretations is brought to the attention of IEEE, the Institute will initiate action to prepare appropriate responses. Since IEEE Standards represent a consensus of concerned interests, it is important to ensure that any interpretation has also received the concurrence of a balance of interests. For this reason, IEEE and the members of its societies and Standards Coordinating Committees are not able to provide an instant response to interpretation requests except in those cases where the matter has previously received formal consideration. A statement, written or oral, that is not processed in accordance with the IEEE-SA Standards Board Operations Manual shall not be considered the official position of IEEE or any of its committees and shall not be considered to be, nor be relied upon as, a formal interpretation of the IEEE. At lectures, symposia, seminars, or educational courses, an individual presenting information on IEEE standards shall make it clear that his or her views should be considered the personal views of that individual rather than the formal position, explanation, or interpretation of the IEEE.

Comments for revision of IEEE Standards are welcome from any interested party, regardless of membership affiliation with IEEE. Suggestions for changes in documents should be in the form of a proposed change of text, together with appropriate supporting comments. Comments on standards and requests for interpretations should be submitted to the following address:

Secretary, IEEE-SA Standards Board  
445 Hoes Lane  
Piscataway, NJ 08854  
USA

Authorization to photocopy portions of any individual standard for internal or personal use is granted by The Institute of Electrical and Electronics Engineers, Inc., provided that the appropriate fee is paid to Copyright Clearance Center. To arrange for payment of licensing fee, please contact Copyright Clearance Center, Customer Service, 222 Rosewood Drive, Danvers, MA 01923 USA; +1 978 750 8400. Permission to photocopy portions of any individual standard for educational classroom use can also be obtained through the Copyright Clearance Center.

**3.1.18 Device number 18—accelerating or decelerating device**

A device that is used to close or cause the closing of circuits that are used to increase or decrease the speed of a machine.

**3.1.19 Device number 19—starting-to-running transition contactor**

A device that operates to initiate or cause the automatic transfer of a machine from the starting to the running power connection.

**3.1.20 Device number 20—electrically operated valve**

An electrically-operated or -controlled device used in a fluid, air, gas, or vacuum line.

NOTE—The function of the valve may be more completely indicated by the use of suffixes as discussed in 3.3.

**3.1.21 Device number 21—distance relay**

A device that functions when the circuit admittance, impedance, or reactance increases or decreases beyond a predetermined value.

**3.1.22 Device number 22—equalizer circuit breaker**

A device that serves to control or make and break the equalizer or the current balancing connections for a machine field, or for regulating equipment, in a multi-unit installation.

**3.1.23 Device number 23—temperature control device**

A device that functions to control the temperature of a machine or other apparatus, or of any medium, when its temperature falls below or rises above a predetermined value.

NOTE—An example is a thermostat that switches on a space heater in a switchgear assembly when the temperature falls to a predetermined value. This should be distinguished from a device that is used to provide automatic temperature regulation between close limits, which would be designated as device function 90T.

**3.1.24 Device number 24—volts per Hertz relay**

A device that operates when the ratio of voltage to frequency is above a preset value or is below a different preset value. The relay may have any combination of instantaneous or time-delayed characteristics.

**3.1.25 Device number 25—synchronizing or synchronism-check relay**

A synchronizing device that produces an output that causes closure of a circuit breaker between two circuits whose voltages are within prescribed limits of magnitude, phase angle, and frequency. It may or may not include voltage or speed control. A synchronism-check relay permits the paralleling of two circuits that are within prescribed (usually wider) limits of voltage magnitude, phase angle, and frequency.

**3.1.26 Device number 26—apparatus thermal device**

A device that functions when the temperature of the protected apparatus (other than the load-carrying windings of machines and transformers as covered by device function number 49), or that of a liquid or other medium, exceeds a predetermined value; or when the temperature of the protected apparatus or that of a liquid or other medium, exceeds a predetermined value or decreases below a predetermined value.

## LIST OF PUBLICATIONS

1. K. N. Dinesh Babu, R. Ramaprabha and V. Rajini, “*Mathematical Modeling and Simulation of Grid Connected Solar Photovoltaic System*”, International Journal of Electrical and Electronics Engineering (IJEEE), ISSN 2231-5284, Vol. 2, No.1, 2012.  
*Received ‘inter-science young investigator’ award for the best presentation/contents category.*
2. K. N. Dinesh Babu, R. Ramaprabha, V. Rajini, Kamal Bansal, “*Analysis of Synchronization techniques for photovoltaic fed Grid systems*”, Wulfina Journal, ISSN 1561-882X, Vol 20, No.5, May 2013, Impact Factor-0.267.
3. K. N. Dinesh Babu, R. Ramaprabha, V. Rajini, Kamal Bansal, “*Charge pump phase locked loop technique in solar photovoltaic grid connected systems*”, International Organization of Scientific Research-IOSR, DOI : 10.9790/0661-16179198, Impact Factor-1.686
4. K. N. Dinesh Babu, R. Ramaprabha, V. Rajini, Kamal Bansal, “*Auto synchronization of photovoltaic fed Grid systems*”, Journal of Power Electronics. (*Under Review*)
5. K. N. Dinesh Babu, R. Ramaprabha, V. Rajini, Kamal Bansal, Bala Vinayagam, “*Comprehensive analysis of auto synch techniques in SPV grid connected systems*”, IET Renewable Power Generation. (*Under Review*)

## VITAE



**K N Dinesh Babu** is a doctoral research scholar with University of Petroleum and Energy studies, Dehradun, India. He obtained his BE degree in Electrical and Electronics Engineering from Sri Sivasubramaniya Nadar College of Engineering, University of Madras, Tamil Nadu, India.

He has 10 years of industrial experience in the field of **Power System Protection** and has worked for Alstom and Asea Brown Boveri (ABB) as Testing/Commissioning and Design Engineer in India, Syria and Taiwan. He is currently working for General Electric (GE) as a Lead Application Engineer and customer training faculty at GE training centers. He is a visiting faculty at Indian School of Petroleum and conducts training session at Gujarat and Rajasthan Electricity Board. He gives guest lectures at CPRI, Bangalore on synchrophasors and smart sub stations.

He is a DFSS certified six sigma green belt and an active member of IEEE. His areas of interest are electric traction, power system protection and renewable energy utilization. He has published 3 research articles in international journals and 1 in international conference.