



# DESIGN OF CATHODIC PROTECTION (IMPRESSED CURRENT) SYSTEM FOR MATHURA CITY GAS DISTRIBUTION

By Jitendra Singh

M-Tech (Pipeline Engineering)

(2013-2015)



College of Engineering

University of Petroleum & Energy Studies

Dehradun

April, 2015



# DESIGN OF CATHODIC PROTECTION (IMPRESSED CURRENT) SYSTEM FOR MATHURA CITY GAS DISTRIBUTION

A thesis submitted in partial fulfillment of the requirements for the Degree of

Master of Technology

(Pipeline Engineering)

Submitted by:

**Jitendra Singh**

**SAP ID: 500026362**

Under the Guidance of

**Mr. S K Kurre**

Assistant Professor Senior Scale

Department of Mechanical Engineering

University of Petroleum & Energy Studies

Dehradun – 248007

Approved

.....

Dean

College of Engineering

University of Petroleum & Energy Studies, Dehradun

April, 2015



## CERTIFICATE

This is to certify that the work contained in this thesis titled “**DESIGN OF CATHODIC PROTECTION (IMPRESSED CURRENT) SYSTEM FOR MATHURA CITY GAS DISTRIBUTION**” has been carried out by Jitendra Singh under my supervision and has not been submitted elsewhere for a degree.

.....

.....

.....

.....

.....

.....

.....

.....

Date

Date



## “ABSTRACT”

The main source of transportation of natural gas is pipeline network system. The backbone of the distribution network is the main steel pipeline that brings natural gas from source to the CNG station. The under ground pipeline system ensures safe and uninterrupted supply of natural gas to the end user. Various cities in different states of India have already implemented with CNG. And it is found to catch a great place in the other states of the country in upcoming years. Segment such as industrial, commercial transport and domestic are being supplied piped Natural gas and Compressed Natural gas respectively as clean fuel.

Pipe that is buried underground or water has a tendency to have external corrosion which is very critical from both point of view technical as well as economical. To overcome this problem of corrosion and prevent our pipelines for safe supply we are using **Cathodic Protection** technique. Cathodic protection can, in principle, be applied to any metallic structure in contact with a bulk electrolyte. In practice its main use is to protect steel structure buried in soil or immersed in water.



## ACKNOWLEDGEMENT

It has been an immense pleasure and truly enriching experience doing my project at the Mathura division of **Sawariya Gas Limited**. I take this opportunity to thank all of those people who have made this experience a memorable one. Firstly, I would like to thank my guide **Mr. Rajul Verma, Project Manager** who has been instrumental and a guiding force behind the completion of this project. He has been constantly eliciting insights and viewpoints on the subject matter.

I also indebted to **Mr. Mayank Sharma** for giving me an opportunity to do my project work in **Swariya Gas limited**.

**My** sincere thanks to each and everyone who are all connected with this work.

I am extremely glade to express our sincere gratitude to my project coordinator **Mr. S. K. Kurre** (Professor, University of Petroleum & Energy Studies, Dehradun ), for giving me , with his valuable advice and assistance throughout the project.

**Jitendra Singh**

**UPES, Dehradun**



## CONTENT

| Sr. No. | Content   | Page No. |
|---------|---|----------|
| 1       | FUNDAMENTAL OF CORROSION                                |          |
| 1.1     | Introduction  | 8        |
| 1.2     | Principal of corrosion                                  | 9        |
| 1.3     | Most important factor for pipeline corrosion            | 10       |
| 1.4     | Corrosion due to bacteria                               | 11       |
| 1.5     | Corrosion due to carbon dioxide ( CO <sub>2</sub> )     | 12       |
| 1.6     | Effects of Various Environmental Factors                | 12       |
| 1.7     | Corrosion prevention                                    | 18       |
| 1.8     | Corrosion Monitoring                                    | 21       |
| 1.9     | Corrosion Economics                                     | 24       |
| 2       | PRINCIPAL OF CATHODIC PROTECTION                        |          |
| 2.1     | Principal of cathodic protection                        | 25       |
| 2.2     | Cathodic disbondment                                    | 29       |
| 2.3     | Process of cathodic protection                          | 31       |
| 2.4     | Cathodic protection applications                        | 33       |
| 2.5     | Advantage and Uses of cathodic Protection               | 34       |
| 3       | IMPRESSED CURRENT CATHODIC PROTETION SYSTEM             |          |
| 3.1     | INTRODUCTION TO TOPIC                                   | 37       |
| 3.2     | Impressed Current Rectifier                             | 38       |
| 3.3     | Impressed Current Anode Materials                       | 38       |
| 3.4     | Types of Impressed Current Anode Beds                   | 41       |
| 3.5     | Advantage and disadvantage of impressed current systems | 43       |
| 3.6     | ICCP anode material                                     | 44       |



|      |  |    |
|------|--|----|
| 3.7  | Ac operated auto/manual transformer rectifier unit             | 45 |
| 4    | Cathodic protection design methodology                         |    |
| 4.1  | Introduction cathodic protection design                        | 46 |
| 4.2  | Methods of applying cathodic protection                        | 49 |
| 4.3  | Design   | 52 |
| 4.4  | Design consideration   | 54 |
| 4.5  | Steps in designing cp installation                             | 56 |
| 4.6  | Impressed current cathodic protection system design            | 56 |
| 4.7  | Other requirement  | 62 |
| 4.8  | Calculations   | 65 |
| 4.9  | Surveys & measurements for cp design                           | 69 |
| 4.10 | Dangers to be avoided  | 72 |
| 5    | Design of cathodic protection                                  |    |
| 5.1  | Cathodic protection at cased crossing                          | 74 |
| 5.2  | Cathodic protection for carrier pipe                           | 75 |
| 5.3  | Data sheet for Zinc Ribbon Anode                               | 76 |
| 5.4  | Additional data to be collected                                | 76 |
| 5.5  | Cathodic protection design parameters                          | 77 |
| 5.6  | Cathodic protection design criteria                            | 78 |
| 5.7  | Steps by step Design Calculation                               | 79 |
| 5.8  | Design of main pipe line of MATHURA                            | 84 |
| 6    | . Conclusion of project  | 92 |
| 7    | Other data required  | 93 |
| 7.1  | Recommended Anode Utilization Factor for CP Design Calculation |    |



## CHAPTER 1

## FUNDAMENTAL OF CORROSION

### 1.1 Introduction

The first practical use of cathodic protection was done in 1980s. The most rapid development of cathodic-protection system was made in the united States of America to meet the requirements of the rapidly oil and natural gas industry which wanted to benefit from the advantages of using thin walled steel pipe for underground transmission. For that purpose the method was well established in the united states in 1945.

In the United Kingdom, where low pressure thicker-walled cast-iron pipes were extensively used, very little cathodic protection was applied until the early 1950s. the increasing use of cathodic protection has arisen from the success of the method used from 1952 onward to protect about 1000 miles of wartime fuel-line network that had been laid between 1940 and 1944. The method is now well established.

Cathodic protection can, in principle, be applied to any metallic structure in contact with a bulk electrolyte. In practice its main use is to protect steel structures buried in soil or immersed in water. It cannot be used to prevent atmospheric corrosion. Structures commonly protected are the exterior surfaces of pipelines, ships' hulls, jetties, foundation piling, steel sheet –piling and offshore platforms. Cathodic protection is also used on the interior surfaces of water -storage tanks and water-circulating systems.

However, since an external anode will seldom spread the protection for a distance of more than two or three pipe-diameters, the method is not suitable for the protection of small-bore pipe work cathodic protection has also been applied to steel embedded in concrete, to copper-based alloys





in water systems, and, exceptionally to lead-sheathed cables and to aluminium alloys, where cathodic potentials have to be very carefully controlled.

## 1.2 Principal of corrosion

Metals are normally found in nature in one their lowest energy states usually as oxides sulfides, chlorides, etc. In reducing and refining metals to produce useful alloys (such as the carbon and low alloy steels used in gas and oil transmission pipelines), significant amounts of energy are consumed and “stored” with in the reduced metallic structures. Subsequent corrosion of steel pipelines thus represents the natural tendency of the iron in the pipe to returned to a preferred, lower energy state (usually as an oxide, carbonate or sulfide).

Corrosion of steel – at the relatively low temperatures ( less than 200 degrees F.)normally encountered in pipeline operations – takes place by an electrochemical process. This process in turn requires the presence of anodic and cathodic areas on the surface of pipe and the presence of a suitable , conductive aqueous environment that contacts both the anodic and cathodic areas. For buried pipe, the external corrosion environment will usually consist of moist, relatively high conductivity soil. Internal corrosion can occur if water exits within the line and is allowed to accumulate at low spots in the line.

The consumption of the steel pipe occurs at the anodic areas on its surface by oxidation of the iron of the pipe wall. The anodic portion of the corrosion process can thus be represented by equation (1):



The cathodic portion of the electrochemical corrosion process may reportedly occur by one of several reactions, depending upon the conditions of the environment:

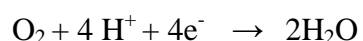
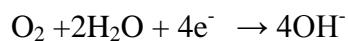

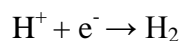
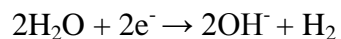

The ultimate rate of the  $\text{Fe}^{++}$  ion from equation (1) also depends upon the environment the Fe may stay in solution as the ion or it may be precipitated as  $\text{Fe}(\text{OH})_2$  or as  $\text{FeCO}_3$ . For external corrosion in moist soils, the ultimate corrosion product is usually  $\text{Fe}(\text{OH})_2$ , while internal corrosion involving carbon dioxide often results in  $\text{FeCO}_3$  as a corrosion product.

**Table 1.1: Corrosion of steel in soil (Table A)**

| Area                    | Corrosion | Corrosion severity | Resistivity   |
|-------------------------|-----------|--------------------|---------------|
| Average of several Soil | 61        | Moderate corrosive | 1000 to 2000  |
| Tidal marsh             | 100       | Corrosive          | 500 to 1000   |
| Clay                    | 137       | Very corrosive     | Less than 500 |
| Sandy loam              | 21        | Mildly corrosive   | 2000 to 10000 |
| Desert sand             | 5         | Non corrosive      | Above 10000   |

*Reference: National Association for Corrosion Engineers NACE*

### **1.3 Most important factor for pipeline corrosion**

- Different in oxygen availability which results in long cell action.
- Ph has no effect on corrosion if it remains between 5-9. This is range in most soil fall.



- Even in more acidic soils, their static nature makes it difficult for fresh hydronium ions to be brought on the surface of the steel.
- Thus there is a general belief that the major reason for corrosion of pipelines must be attributed to micro-organisms.

## **1.4 Corrosion due to bacteria**

Anaerobic bacteria which act in the absence of oxygen. The most common in this category is the SRB Sulphate reducing bacteria. As the name suggest it reduces the sulphate in the soil and consume hydrogen in the process. Consumption of hydrogen at the pipe surface acts to depolarize steel at cathodic areas and permit more rapid consumption of metal. Thus bacteria do not attack directly but provide conditions conducive to more rapid attack by existing corrosion cells.

Such a process requires more current by cathodic protection. (An additional 100 MV of protective potential is applied in the presence of bacteria). Aerobic bacteria which act in the presence of oxygen. Any sulphide present is converted to acids which in turns attack steel.

Bacteria are found in all pipelines locations. Although they are of tiny size their large number can produce respectable mass. An acre foot of a soil is expressed to contain 5 tons of bacteria.

During a bell hole examination adjacent to a coated pipeline, the bacteria population was 10-100 times more from the undisturbed earth at pipe depth. Such a variation was not found in the case of bare pipe.

The bacterial activity adjacent to a coated pipeline is an excellent indication of the good food supply.

### **Effect of Bacteria on coating**

- The coating attacked by bacteria usually becomes unstable.

- Bacteria can consume asphalt certain tape adhesive kraft paper blinders and fillers used in felt pipeline wrappers.
- Coating derived from coal and petroleum pas certain tests and ail in others.
- Certain materials which are good as such fail when rein forced with others.
- Fungi appear to be particularly aggressive to many materials commonly used as coatings underground.

### 1.5 Corrosion due to carbon dioxide ( CO<sub>2</sub> )

Carbon dioxide is a naturally occurring component in many oil and gas fields. As such carbon dioxide is not corrosive. Presence of water dissolves carbon dioxide resulting in the formation of carbonic acid which causes the corrosion of steel. The corrosion of steel in the formation of carbonic acid which causes the corrosion of steel. The corrosion of steel in the presence of carbonic acid depends on several factors the important one being temperature H<sub>2</sub>S carbon monoxide salt content and flow velocity. The type of attack can be uniform pitting or stress corrosion cracking.

**Table 1.2: Types of carbon dioxide corrosion on steels ( Table B )**

| Type 1                               | Type 2                          | Type 3                               |
|--------------------------------------|---------------------------------|--------------------------------------|
| Low temp 40 c                        | Intermediate temp 100 c         | High temp 150 c                      |
| General corrosion                    | Pitting corrosion               | Protective oxide                     |
| Bulk deposition of feco <sub>3</sub> | deposition of feco <sub>3</sub> | Formation of tight feco <sub>3</sub> |

*Reference : National Association for Corrosion Engineering NACE*

### 1.6 Effects of Various Environmental Factors

#### Effect of pH (Hydrogen Ion Concentration)

It is one of the most critical parameters in the corrosivity determination

It lowers with dissolved CO<sub>2</sub> and H<sub>2</sub>S

Ph can be determined as a function of acid gas partial pressure bicarbonates and temperature.



From a practical stand point of contribution of  $\text{H}_2\text{S}$  or  $\text{HCO}_3$  or temperature to Ph determination is another way of representing effective levels of  $\text{CO}_2$  that would have produced a given level of Ph.

$\text{CO}_2$  corrosion mechanism is dissimilar to that of strong acids like **HCl** where  $\text{H}^+$  are produces it progress through direct reduction of  $\text{H}_2\text{CO}_3$  to  $\text{HCO}_3$  rather than reduction of  $\text{H}^+$  ions and that carbonic acid corrosion is much more corrosive than that obtained from a strong acid such as HCL at the sample pH. There is also significantly agreement that lower pH levels obtained from higher acid gas presence leads to higher corrosion rates.

Conversely higher levels of pH obtained through buffering in simulated production formation water solution have been shown to produce significantly lower corrosion rates even at higher levels of  $\text{CO}_2$  and / or  $\text{H}_2\text{S}$ .

### **$\text{CO}_2$ dominant system with small amount of $\text{H}_2\text{S}$**

Lead to the formation of an iron sulfide scale called mackinawite at temperature below  $120^\circ\text{C}$ . However the FES scale produced is directly function of  $\text{Fe}^{++}$  and  $\text{S}^-$  and is influenced by pH and temperature. This surface reaction can lead to the formation of a thin film that can mitigate corrosion.

### **$\text{H}_2\text{S}$ dominated systems**

Preferential formation of a metal stable sulfide film in preference to the  $\text{FeCO}_3$  scale hence there is protection available due the presence of the sulfide film in the range of temperature  $60^\circ\text{C}$  to  $240^\circ\text{C}$ .

- At higher concentrations and temperatures, FeS becomes the more stable pyrrhotite.
- However at temperature below  $60^\circ\text{C}$  or above  $240^\circ\text{C}$  the presence of  $\text{H}_2\text{S}$  exacerbates corrosion in steel since the presence of  $\text{H}_2\text{S}$  prevents the formation of a stable  $\text{FeCO}_3$  scale.



- Further it has been observed that FeS film itself becomes unstable and porous and does not provide protection.

### **Effect of Chlorides**

The chloride concentration in produced water from hydrocarbon formation can vary from zero to few ppms for condensed water to saturation in formation waters having high total dissolved salts/solids (TDS) .

In naturally de-aerated production environments corrosion rate increase with increasing chloride ion content over the range 10,000 ppm to 10,0000 ppm.

The magnitude of this effect increase with increasing temperature over 60<sup>0</sup>C. This combined effect results from the fact that chloride ions in solution can be incorporated into and penetrate surface corrosion films which can lead to destabilization of the corrosion film and lead to increased corrosion.

This phenomenon of penetration of surface corrosion films increase in occurrence can be obtained as 0.63 \*ppm NaCl. Typically brines with low chloride content (<10000 ppm) are less aggressive than those having higher chloride contents provided that they are compared at the same pH. Presence of chlorides can affect the effectiveness of chemical corrosion inhibitors. Therefore a careful selection if inhibitors and inhibition procedures must be performed where levels of chlorides (> 30000 ppm) are present.

### **Effect of Oxygen**

Presence of oxygen significantly alters the corrosivity of the environment in the production system and also Presence of oxygen can significantly increase corrosion rates due to acceleration of anodic reaction is further exacerbated by Increase in operating temperature.

Increasing oxygen concentration

Increase fluid flow leading to increased mass flow of oxygen to the metal surface



## **Gas to oil Ratio**

In oil and gas production where the environment has  $GOR < 890 \text{ m}^3 / \text{m}^3$  (5000 scf/bbl in Btu) the tendency for corrosion an environment cracking is substantially reduced. This is caused by the inhibiting effect of the oil film on the metal surface, which effectively reduces the corrosivity of the environment. However the inhibiting effect is dependent on the oil phase being persistent and acting as a barrier between the metal and the corrosive environment. If GOR is not known it is recommended that a value  $> 5000 \text{ SCF/BBL}$  or  $890 \text{ m}^3 / \text{m}^3$  (in SI units) be used.

## **Water to Gas Ratio**

To have corrosion in oil and gas system aqueous water is required. In many production application where essentially dry hydrocarbons are being produced, full corrosivity of the hydrogen sulfide and / or carbon dioxide will not be present

In such system, a dry gas is considered as that which contains no more than 2bbl water/MSCF gas. For water to gas ratio with less than or equal to this amount the corrosive severity is substantially reduced. Care should be taken to evaluate presence of possible location where water can separate from the hydrocarbons and from a continues water phase. Under such condition, substantial corrosion can exist.

## **Dew Point**

In gas dominated system, there are two measures to evaluate availability of the aqueous medium. If the operating temperature is higher than the dew point of the environment, no condensation is going to be possible and will lead to highly reduced corrosion rates.

Corrosion under condensing conditions (i. e. operating temperature  $<$  dew point) is a function of the rate of condensation and transport of corrosion products from the metal surface. If the total water is condensing system as  $\text{m}^3/\text{Mm}^3$ , corrosivity is substantial reduced . Hence the dew point plays a critical role in gas dominated system in that at higher operating temperatures significantly lower or no corrosion may be observed de to absence of condensed moisture.



### **Effect of fluid flow Velocity**

Affects both the composition and extent of corrosion products films.

Typically, high velocities (>4 m/s for non inhibited systems ) in the production streams leads to mechanical removal of corrosion films and the ensuing exposure of the fresh metal surface to the corrosion medium leads to significantly higher corrosion rates.

### **Effect of Multi Phase Flow**

In multi phase (gas, water liquid hydrocarbons ) production, the flow rate influences the corrosion rate of steel in two ways:

It determines the flow behavior and flow regime at low velocities, stratified flow at intermediate conditions and turbulent flow at higher flow rates. One measure which can be used to define the flow condition is a superficial gas velocity. In liquid systems, this is replaced with the liquid velocity.

Velocities less than 1 m/s are considered static-rates can be higher than those observed under moderately flowing conditions as there is no natural turbulence to assist the mixing and dispersion of protective liquids hydrocarbons or inhibitors species in the aqueous phase. Additionally, corrosion products and others deposits can settle out of the liquid phase to promote crevice attack and under deposit corrosion.

Between 1 and 3 m/s. stratified conditioned generally still exist. Increased flow promotes sweeping away of some deposit and increasing agitation and mixing. At 5 m/s corrosion rate are non inhibited applications start to increase rapidly with increasing velocity.

### **Effect of Oil Type**

A system is called as oil dominated on the basis GOR ratio. If the environment has a  $GOR < 890 \text{ m}^3 / \text{m}^3$  (5000 scf/bb/ in Btu) the tendency for the corrosion and environmental cracking is often substantially reduced.





This is caused by the possible inhibiting effect of the oil film on the metal surface, which effectively reduces the corrosivity of the environment. However the inhibiting effect is dependent on the oil phase being persistent and acting as a barrier between and the corrosive environment.

The persistence of the oil phase is a strong factor in providing protection, even in systems with high water cuts. In oil systems with a persistent oil phase and up to 45% water cut, corrosion is fully suppressed, irrespective of the type of hydrocarbons. Relative wettability of the oil phase versus the water phase has a significant effect on corrosion metal surface that are oil wet show significantly lower corrosion rates.

### **Effect of Carbon Monoxide**

- Carbon monoxide with carbon dioxide and water causes stress corrosion cracking failures.
- No stress cracking of mild and low alloy steels occurred in solution containing only CO<sub>2</sub>.
- Cracking was Trans granular.
- Liquids water must be present for cracking to occur.
- Stress cracking occurred over a wide range of CO/CO<sub>2</sub> ratios.
- Susceptibility to cracking decreases with in temperature.
- No cracking was observed for several medium alloys and stainless steel.
- The cracking was observed for several medium alloys and stainless steel.
- The cracking appeared to be stress corrosion cracking rather than hydrogen in embrittlement .

## **1.7 Corrosion prevention**

### **External Corrosion**

The principal methods used to prevent external corrosion of pipelines are coating and cathodic protection (CP) of the lines. In recent installations, coating and CP have normally been used



together in a complimentary fashion, since high quality coatings substantially reduced the CP current requirement and the application of a functioning CP system allows some relaxation in the requirement for 100% “holiday” (defect) free coatings.

## **Coatings**

The NACE Standard RP0169-96[1] lists most of the desirable characteristics of a pipeline coating. These include are following :

1. The coating should have a high electrical resistance and high dielectric strength.
2. The coating should be an effective moisture barrier.
3. The coating should be reasonably easy to apply and the application process should not change the properties of the pipe.
4. The coating should exhibit good adhesion to the pipe.
5. The coating should be resistant to chemical and physical damage/degradation during installation and service.
6. The coating should be reasonably easy to repair in the field.
7. The use of coating should not present any environmental or health risks. Pipeline coatings have been used for more than 70 years and numerous systems have been developed.

The coating systems that are currently being applied include the following:

1. Coal tar enamels containing embedded glass fiber mats.
2. Mill-applied tape systems.
3. Extruded polyethylene and polypropylene coatings.
4. Fusion – bonded epoxy (FBE) coatings.
5. Multi-layer, FBE under extruded polyethylene or polypropylene.

The last three coating systems listed above are reportedly currently experiencing increasing acceptance by consumers and their future use should therefore expand.

## Cathodic protection

The electrochemical basic for cathodic protection systems was presented briefly above in the Corrosion basic sections. The current used to cathodically polarize the sample to be protected can typically come from an “ impressed current ” system using an external, DC power supply

Those supplies current to the pipe by way of a remote anode “ground bed”.

Alternatively, the protective current can come from a reactive, “Galvanic” anode or group anodes. Galvanic anodes are typically located with in 10 to 20 feet of the spot on the pie to be protected.

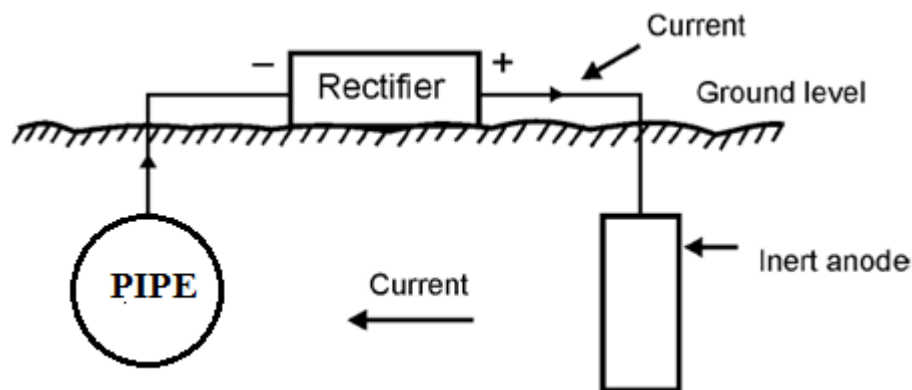

**Figure 1 cathodic protection of pipe Using Impressed Currents**

**Reference: NACE RP0169-96 “control of external corrosion on underground or submerged Metallic piping systems”**

## Internal corrosion

Internal corrosion in a pipeline requires the presence of liquid water within the line. In gas transmission line (the only pipe line that will be disused in the documents), internal corrosion also usually singles presence of significance partial pressures of carbon di oxides and / or hydrogen sulfide in the line.



It is also known, however, that on a weight percentage or weight fraction basis dissolved oxygen is more corrosive to ordinary steels than either carbon dioxide or hydrogen sulfide. Although the probability of having appreciable concentration of oxygen inside a gas transmission line is apparently quite low, it should be remembered that even small partial pressure of oxygen can produce surprisingly high internal corrosion rates in steel pipes that also contain liquid water.

One method to reduce the danger of internal corrosion by the acid gases, carbon dioxide and hydrogen sulfide, is to reduce the concentration of the acid gases in the gas transmission stream by a process known as “Gas sweetening”. Many gas sweetening processes have been developed and used. These include, for example;

- Solid bed absorption (using iron sponge, mole sieves or zinc oxide)
- Chemical solvent (such as mono ethanol amine, di-ethanol amine, potassium carbonate, etc).
- Proprietary physical solvent.
- Conversion of hydrogen sulfide to sulfur.
- Distillation.

Water can form in a pipe line if there has been no attempt to dehydrate gas prior to its introduction into the line or if the gas dehydration process that was used did not produce water contents in the gas that were low enough to prevent condensation of liquid water in the line. If the gas temperature drops below its water dew point, liquid water will probably form. Liquid water that is produced in the line will, of course, tend to accumulate at the low point in the line. Here, the water will equilibrate with carbon dioxide and/or hydrogen sulfide in the gas and can produce local areas of high internal corrosion rates. A second effective method used to prevent internal corrosion of gas transmission pipelines is thus dehydration of the gas prior to its introduction into the line. The aim of the dehydration process is to reduce the water content of the gas to a low enough level that the gas will experience in the line. By far the most common dehydration process for natural gas involves contacting with a hygroscopic liquid such as Glycol. The most common glycol used for gas dehydration is the use of gas sweetening in conjunction with gas



dehydration will, of course, minimize chance of problems with internal corrosion in gas pipelines.

## **1.8 Corrosion Monitoring**

### **External corrosion**

Survey methods that are commonly used to evaluate the external corrosion condition of pipeline include :

- 1.8.1 pipe-to-soil potential measurements,
- 1.8.2 soil resistivity measurements,
- 1.8.3 measurements of D. C. currents flowing along the pipeline,
- 1.8.4 “Bell hole” examinations of the pipe.

Pipe-to-soil potential measurements are typically made with a saturated copper-copper sulfate (CSE) reference electrode that is placed in contact with the soil directly over the line. The potential measurements are made with a high input impedance voltmeter. Hooking the negative terminal of the voltmeter to the CSE electrode and the positive terminal to the pipeline gives a reading with the normally used sign convention (e.g. the native corrosion potential of bare steel in moist soil will normally read between  $-0.1$  and  $-0.5$  volts).

In pipe-to-soil potential surveys of pipe that is not under cathodic protection (and that has been allowed to reach its “native” corrosion potential prior to starting the measurements), the points on the line with the largest negative potential values normally are the areas with the highest corrosion rates. Newly installed pipe (and pipe sections), will however, usually have pipe-to-soil potentials that are substantially more negative than older sections of line and the pipe-to-soil potential of new pipelines (without CP) will usually tend to decrease in magnitude (become less negative) with the passage of time.

Soil resistivity measurements can be made using either two terminal or four terminal meters. Either an A. C. or D.C. power supply can be used in conjunction with an instrument that accurately measures the current and the potential between the test electrodes. Four terminal



instruments are usually used when larger soil areas are examined or when resistivity's at a greater depths are desired.

Corrosion rates of buried pipes are generally higher in lower resistivity (higher conductivity) soils. Guidelines correlating observed corrosion rates with soil resistivities have been developed. These guidelines are documented in Table no. 1. Because of the possibility of errors caused by voltage drops in the soil due to the flow of CP currents, it is recommended that soil resistivity measurements be made with CP systems shut off.

Line current measurements are typically made using test stations that are installed at the time the pipe was laid. Electrical leads are connected to both ends of the pipe test span and these leads are subsequently used to measure the voltage drop across the test span.

The electrical resistance of the test span is then either estimated or measured and the net electrical current in the test span is calculated using ohm's law. The sign of the voltage drop indicates the direction of the current flow through the test span. In order to eliminate the effects of any active CP system, line currents measurements should be made with those systems shut off.

The current detected in line current measurements are "long-line " currents that are typically caused by widely separated "macro" electrodes (e. g. , different soil conditions along the line) or by interferences from "foreign" D.C. fields in the earth (such as those caused by an adjacent, unconnected CP system ). "long-line" currents are not caused by the local anodes and cathodes that produce the corrosion normally observed on the line. However, at the location(s) where "long-line" currents leave the pipe, the resulting corrosion rates can be very high. For example calculation shows that, if only 10 milliamps of D.C. currents leaves a pipe over an area of 1 square inch on the pipe surface, a corrosion penetration rate of approximately 700 mils(or about 0.7 inches) per year would be observed at that location.

### **Internal corrosion**

Successful monitoring of internal corrosion of pipeline is apparently significantly more difficult than monitoring of external corrosion, as discussed above. One method that may yield valuable



information concerning the general internal condition of a line is to periodically run scraper pigs through the lines. Evaluating the quantity and composition of material that is removed from the line by the scraper pig may be useful in evaluating whether or not significant internal corrosion has been occurring in the line.

The development and use of “smart pigs” may soon allow the successful simultaneous direction and monitoring of both external and internal corrosion/damage in pipelines. Measurement techniques that have been considered and/or used in previous “smart pig” development efforts include:

1. Multi-“finger”, mechanical calipers that detect and record the effective internal radius of the pipe.
2. Magnetic flux-leakage tools that may be configured to respond to both longitudinal and circumferential defects in the pipe. These tools may also include high frequency eddy current sensors that can differentiate between internal and external damage.
3. Ultrasonic tool that couples directly to the pipe wall through a surrounding liquid and that may measure either the internal radius or the wall thickness of the pipe,
4. Ultrasonic tools that use electromagnetic acoustic transducers (EMATs) to evaluate the condition of the pipe wall. These transducers use electromagnetic signals to evaluate the condition of the pipe wall. These transducers use electromagnetic signal to generate ultrasonic signal in the pipe wall. Future use of EMAT technology may overcome the difficulties and shortcomings with direct coupling ultrasonic tools.

## **1.9 Corrosion Economics**

A recent review of the economic effects that corrosion of the metals and alloys costs U.S. companies (and consumers) a total approximately \$300 billion per year.



It also concluded that approximately one third of these total cost (approximately \$100 billion per year) could be significantly reduce or eliminated by the use of current best available corrosion prevention techniques and materials.

In the review, it was estimated that the pipe line industry accounted for something less than 1 percentage of the total industry-wide corrosion costs. This would thus probably put the total cost for corrosion in the pipe line industry some where in the range of \$2 billion to \$3 billion per year.

In case of pipe line industry , as in several other industry segments, the authors of the review felt that, although the need for corrosion-related repairs and re-coating had apparently gone down in the recent past, the savings due to the drop in repairs had been essentially balanced by use of more expensive original materials of construction.

In our opinion, the development of more sensitive and more accurate inspection techniques (such as improved “smart pigs”) and the possible regulatory requirement for the use of these more sensitive inspection techniques could substantially increase the repair costs associated with the future operation of aging gas transmission pipe lines.





## CHAPTER 2

## PRINCIPAL OF CATHODIC PROTECTION

Cathodic protection is an electrochemical technique for preventing corrosion of a metal exposed to an electrolyte. The process involves the application of DC electrical current to the metal surface from an external source. The external source can be either a commercial power source or through connection to sacrificial metals such as magnesium or aluminum, it is used extensively in preventing corrosion to underground and submerged steel structures; such as pipelines , production well casing and tanks.

Effective application of cathodic protection can provide complete protection to any exposed areas for the life of structure. The combination of an external coating and cathodic protection provides the most economical and effective choice for protection of underground and submerged pipelines. For bare or ineffectively coated existing pipelines systems, cathodic protection often becomes the only practical alternative for corrosion protection.

Cathodic protection is mandated requirement of federal and state regulations governing underground transmission pipeline, gas distribution systems, and underground petroleum tanks. These requirements include installation, monitoring and maintenance of cathodic protection systems.

### 2.1 Principal of cathodic protection

The basic concept of cathodic protection is that the electrical potential of the subject metal is reduced below its corrosion potential, and that it will then be incapable of going into solution or corroding. This mechanism have been defined by many scientists and has become established beyond dispute. Indeed the principal of corrosion reactions are used in the design and construction of expendable and re-chargeable batteries and accumulators which play such a major part in modern life.



A battery that is 'dead' has no energy left and does not corrode any further. Likewise a car battery on charge does not corrode, in fact in this case the reaction is reversible, and energy is 'pumped back in'.

However, a battery has a very carefully composed electrolyte which has qualities to ensure a predictable reaction with the other components of the battery. We know that the corrosion within a battery can be controlled very accurately, by external electrical input, as this technique is in with rechargeable which are now days controlled by computers which balance the reaction equilibrium to suit their own power demands.

Unfortunately a cathodic protection system is not composed of simple elements in the way that batteries are, because the electrolyte is ground itself. This electrolyte is uncontrollable and has an almost infinite variety of qualities. The chemical composition and electrical conductivity can span a vast range, as can the temperature and pressure to which the reaction is subjected.

The Cathodic protection of such subject as ships hulls and storage tank bases is relatively simple as the electrolyte is likely to be almost homogenous, but as the size of the structure increases, it extends through different electrolytes and the reaction at each interface varies. Offshore oil rigs, for example have different temperatures and pressures at the sea bed to those at the surface, and a study of this situation has shown that it has a substantial influence on corrosion.

Pipelines can be regarded as many interface reactions connected together in parallel. The metal element can be defined, as this is specified to a high degree by the designers, as is the coating material. However it is accepted that no coating can be perfect and the faults or 'holidays' introduce the first indefinable variable to the system.

During construction of a pipeline all possible measures are taken to detect and repair coating faults, show it follows that those remaining are undefined. It is possible to calculate the theoretical resistance of a perfectly coated pipeline, given the specification of the coating and dimensions of the pipeline, but it is impossible to calculate the actual resistance of the total pipeline.



The electrical currents measurements, taken during routine cathodic protection monitoring, shows that there is little resistance in the total coating (with faults) of a pipeline and this can be explained by the difficulty in quality control, during the construction period.

Undetected coating faults are the path of cathodic protection current and a perfect coating prevent any output from the CP system. We therefore, know that there are many unspecified 'metal to electrolyte' interfaces present on an average pipeline.

The electrical resistance of the pipeline metal itself can be calculated and is found to be very low. In fact the effect that the pipeline resistance has on the complex current paths and variation in current potential is so small that it can almost be ignored.

The completion is to each interface being capable of a different reaction, electro-motive-force (EMF) which cannot be measured as it is in parallel with all other EMF's on the same section of the pipeline. The magnitude of the current from each of these reaction is dependent on earth resistance immediately adjacent to the interface, and the direction of all the resulting currents is the result of the combined effects of all the resistance and electrical pressures caused by all EMF's.

Although it is simple to understand each corrosion cell and the mechanism of corrosion itself, the reality of applying science, to the field, becomes immensely complex. This becomes more obvious when the circuit has been subjected to computer modeling as discussed latter.

To be effective, cathodic protection must reduce the metal at each single interface, to below its corrosion potential. This is not to difficult to achieve, as each interface is part of the same metal structure, which has a very low electrical resistance. The difficulty is knowing when all the interfaces have been reduced to below their corrosion potential in relation to the electrolyte in their reaction vicinity. (Don't forget, if we knew where each interface was we would repair them all)

A common example is:



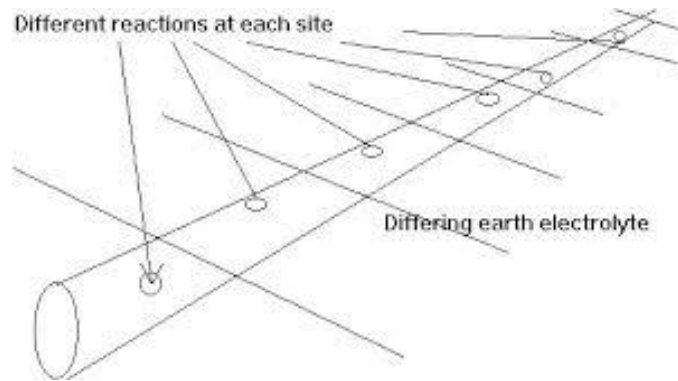

**Figure 2 principal of cathodic protection**

**Reference: [www.freepcae.virgin.net/orge.alexander/technic.htm](http://www.freepcae.virgin.net/orge.alexander/technic.htm)**

This reaction produces free electrons, which pass with in the metal to another site on the metal surface (the cathode) where it is consumed by the cathodic reaction. In acid solutions the cathodic reaction is:



In neutral solution the cathodic reaction involves the consumption of oxygen dissolved in the solution:

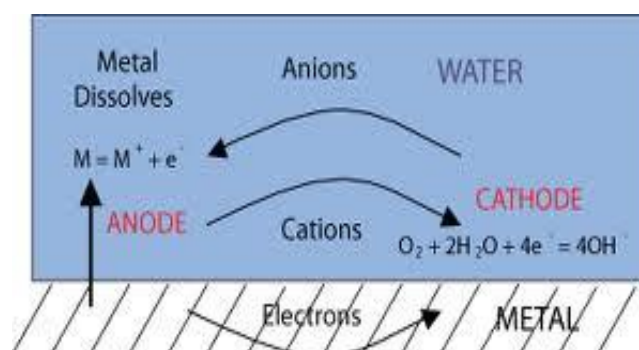
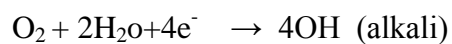

**Figure3: corrosion cell/ bimetallic corrosion**



**Reference: National Association of corrosion Engineers (NACE)**

## **2.2 Cathodic disbondment**

Another fear of over protection is that of cathodic disbondment of the coating. This happens when the coating manufacturers specifications are exceeded. Cathodic protection current passing on to the metal causes the release of hydrogen which disbonds the coating. In reality this is a rarely a problem and a careful study reveals why.

The current will only pass on to the metal at a coating fault, and the density of the current will depend on the size of the coating fault and the current locally available. As the current blows the coating from the metal, the volts drop at the interface will decrease, and equilibrium will be reached with a very small increase in additional disbondment.

If there is no coating fault then no cathodic disbondment will occur as recognized in the British standard code of practice for testing the coating manufactures specifications. This requires a specify size of coating fault on a steel coupon, to be subjected to an increasing voltage over a specify period. The test cannot be carried out on a coupon with perfect coating as the disbondment is observed under the coating at the edge of the fault. It is logical to deduce that if cathodic disbondment is caused by current and that if all current is prevented by a perfect coating, than no disbondment will take place. This not common science however as many excavation have been dug in areas where high pipe-to-soil potentials have caused concern about cathodic disbondment. In the event it has proved the logic (above) and no disbondment has been found.

In one particular example voltages of over 5 volts had been recorded when the electrode was place on the surface above the buried pipeline which was subsequently excavated, at several spots for examination. A coating fault was found at one location but no disbondment. The current passing on to the metal at this coating fault cause a drop in the voltage of the electrode as it got nearer to the pipe. Whereas at the surface and reading had been over 5 volts, this reduced

to 0.950 volts when the electrode could be placed close to the actual interface between the metal and the earth.

This simple drawing show that the earth at the surface has a higher potential than the earth close to the pipeline at the coating fault due to the current passing from ‘mass earth’ into the pipe metal.

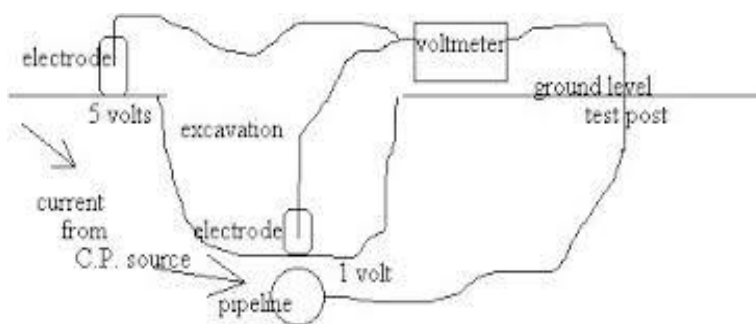

**Figure4: Potential Gradient**

**Reference: [www.freepcae.virgin.net/orge.alexander/technic.htm](http://www.freepcae.virgin.net/orge.alexander/technic.htm)**

At such site it is easy to plot the ‘potential gradient’ using a static electrode as a reference and a moving electrode to trace the potential isobars. As soon as the coating fault is fully exposed to the air, the gradient disappears completely as the current stops. The meter than reads 5 volts even with electrode place in the ground a few mm from the metal.



**Table2.1 Steel pipe Resistance**

| Pipe size, thickness | Outside Diameter Inches | Wall Thickness, Inches | Weight Per Foot, Pound | Resistance of One Foot <sup>(2)</sup> in Ohms* X 10 <sup>8</sup> (Millions of an Ohms) |
|----------------------|-------------------------|------------------------|------------------------|--|
| 2                    | 2.375                   | 0.154                  | 3.65                   | 79.2   |
| 4                    | 4.5                     | 0.237                  | 10.8                   | 26.8   |
| 6                    | 6.625                   | 0.280                  | 19.0                   | 15.2   |
| 8                    | 8.625                   | 0.322                  | 28.6                   | 10.1   |
| 10                   | 10.75                   | 0.365                  | 40.5                   | 7.13   |
| 12                   | 12.75                   | 0.375                  | 49.6                   | 5.82   |
| 14                   | 14.00                   | 0.375                  | 54.6                   | 5.29   |
| 16                   | 16.00                   | 0.375                  | 62.6                   | 4.61   |

<sup>(1)</sup> Based on steel density of 489 pound per cubic foot and soil resistivity of 18 microhm-cm stated in text.

$$^{(2)} R = \frac{16.061 \times \text{Resistivity In Microhm-cm}}{\text{Weight per foot}} = \text{resistance of on foot of pipe in microhms}$$

### 2.3 Process of cathodic protection

Cathodic protection initially means the reduction or elimination of corrosion on a metal surface by forcing a metal become a cathode. The two general types of cathodic protection system are impressed current and sacrificial. Both types of system can effectively transfer the corrosion reaction (oxidation) from the metal surface to an external anode. If all exposed parts of a structure become cathodic with respect to electrolyte, corrosion of the structure is eliminated.

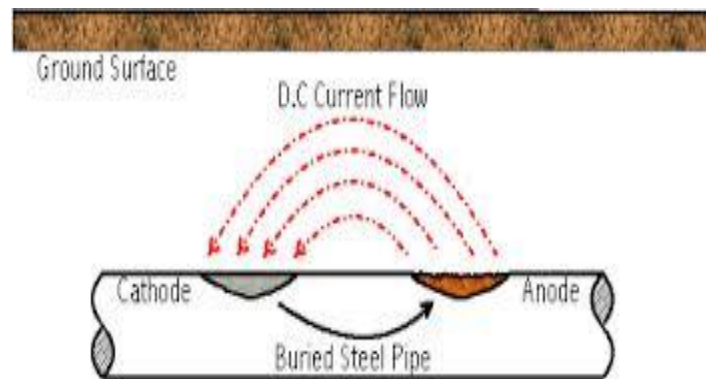

**Figure5: cathodic protection process**

**Reference: National Association of corrosion Engineers (NACE)**

### **Impressed current cathodic protection**

Impressed current cathodic protection involves application of an external DC current through long lasting anodes. Typical source of power for an impressed current system in ac power convert to DC by a rectifier.

In order to be effective, impressed current anodes must be designed for long life at high current output. This requires selection of materials with very low corrosion (consumption) rates. The typical expectation of impressed current anode life is over 20 years. Anode materials that have proven to be suitable for impressed current systems include treated graphite, high silicon cast iron, mixed metal oxide and to a lesser extent platinum and magnetite. Anodes are normally installed in grouped configuration in the electrolyte. These groupings (both horizontal and vertical) in an underground application are called ground beds. The ground beds are connected to the power by a positive cable to the power source. A negative cable connects the power source to the structure.

Advantages of impressed current systems include unlimited current opportunities and longer life. Impressed current systems are typically installed where the structure to be protected is large, requiring higher levels of currents.



Disadvantage include the requirement for an out side power might come from source such as commercial AC convert to DC through a rectifier, thermoelectric generator, or solar panels.

A significantly higher monitoring and maintenance effort is required by comparison to sacrificial anode systems.

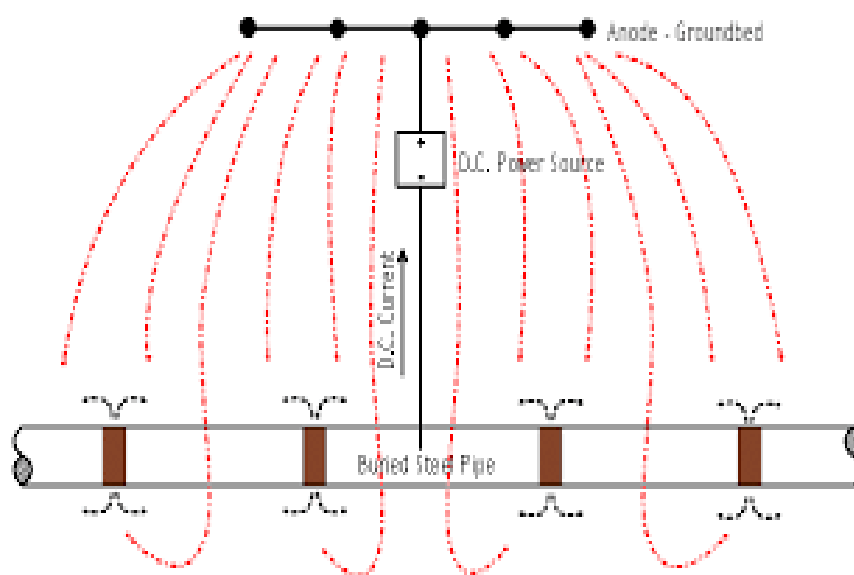

**Figure6: Impressed Current System**

**Reference: National Association of corrosion Engineers (NACE)**

## 2.4 Cathodic protection applications

Cathodic protection can be effectively applied to the most steel structures in consistent contact with a corrosive electrolyte. Commonly protected structures include buried pipelines, underground tanks (UST's), aboveground tank bottoms (AST's), well casings, internal surfaces of tanks and treating vessels, and offshore structures.



- **Underground pipelines** are the primary market for the cathodic protection. Both sacrificial and impressed current systems are used. Federal and state regulations require cathodic protection for most petroleum and gas pipeline systems.
- **Underground storage tanks (UTS's)** used for fuel are now required by EPA to either have functional cathodic protection system or to be a non-corrosive material. Both types of systems are widely used.
- **Aboveground storage tanks (AST's)** bottom can be protected from soil-side corrosion with cathodic protection. Most major tanks operators include cathodic protection in their corrosion control program. Unique problems involved with tank applications include the difficulty of distributing current uniformly over the tank bottom and monitoring the effectiveness of systems.
- **Production Well Casing** usually require impressed current systems due to higher current requirements. The economics of cathodic protection are excellent until production volume decline and fields near the end of their effective life. This application of cathodic protection is common; but tends to be concentrated in established fields with known corrosion history.
- **Internal surfaces** of tanks and vessels are commonly protected by cathodic protection systems. With some exceptions, most of these utilize sacrificial anodes. Possible applications range from heater-treaters, heat exchangers, water storage tanks, and hot water heaters.
- **Offshore structures** such as production platforms, docks, and pipelines are almost always protected with cathodic protection systems. Sacrificial anode systems with aluminium anode are the most common application.

## 2.5 Advantage and Uses of cathodic Protection

The main advantage of cathodic protection over other forms of anti-corrosion treatment is that it is applied simply by maintaining a DC circuit and its effectiveness may be monitored continuously. Cathodic protection is commonly applied to a coated structure to provide corrosion



control to areas where the coating may be damaged. It may be applied to existing structures to prolong their life.

Specifying the use of cathodic protection initially will avoid the need to provide a “corrosion allowance” to thin section of structures that may be costly to fabricate. It may be used to afford security where a small leak cannot be tolerated for reasons of safety or environment . cathodic protection can, in be applied to any metallic structure in contact with a bulk electrolyte (including concrete). In practice, its main use to protect steel structures buried in soil or immersed in water. It cannot be used to prevent atmospheric corrosion on metals. However, it can be used to protect atmospherically exposed and buried reinforced concrete from corrosion, as the concrete from corrosion, as the concrete itself contains sufficient moisture to act as the electrolyte.

Structures that are commonly protected by cathodic protection are the exterior surface of:

- Pipelines
- Ship’s hulls
- Storage tank bases
- Jetties and harbor structures
- Steel sheet, tabular and foundation pilings
- Offshore platforms, floating and subsea structures

Cathodic protection is also used to protect the internal surfaces of large diameter pipelines water-circulating systems.

- Ship’s tanks (product and ballast)
- Storage tanks (oil and water)



However since an internal anode will seldom spread the protection for a distance of more than two to five pipe-diameters, the method is not usually practical , or suitable, for the protection of small-bore pipe work.

Cathodic is applied to control the corrosion of steel embedded in reinforced concrete structures (bridges, buildings, port and harbor structures, etc )

See guide in corrosive control, corrosion and protection of steel in concrete and it's monitoring. Cathodic protection can be applied to copper-based alloys in water systems, and, exceptionally, to lead-sheathed cables and to copper- based alloys where cathodic potentials have to be controlled very carefully.



## CHAPTER3 IMPRESSED CURRENT CATHODIC PROTETION SYSTEM

### 3.1 Introduction to topic

As galvanic anode system, impressed current system supply current for cathodic protection of a metal surface. However, in the case of impressed current cathodic protection system, the protective current is supplied by a rectifier (or other DC power source) instead of by the natural potential difference of the anode to the structure. The potential difference between the anode and cathode is forced from a non-reactive anode bed by the action of anode energy from a rectifier to force the electron flow that would be normally produced in the corrosion reaction. The energy for the “electron energy pump” action of the rectifier is provided by ordinary alternating current. The effect of these electrons at the structure being protected is the same as derived from th sacrificial anode type of cathodic protection system.

However, the anode material serves only as a source of electrons and anodic (oxidation) electrochemical reactions. In practice, material such as graphite, high silicon cast iron (HSCI), platinum or mixed metal oxide, are used for impressed current cathodic protection system anodes because they are slowly consumed(they have a very low kilogram(pound) per amp year weight loss). To provide uniform electrolyte, a lower resistance to earth, and venting of gases and acids, a special backfill is used. This earth contact backfill is normally coke breeze fluid petroleum coke. Anodes in impressed current cathodic protection systems must be periodically inspected and replaced if consumed or otherwise damaged.

As is the case for any electrical equipment, rectifier used for impressed current cathodic protection systems require preventive maintenance and recurring operational checkouts to ensure proper operation. Impressed current system anode leads must have a special insulation to preclude the copper lead wire from becoming the part of the anode system. Science the power



source is forcing everything connected to the positive terminal to act as an anode (and corrode) any defect or nick in the insulation of the anode lead wire would result in copper metal loss ending in failure of the anode system.

Impressed current cathodic protection systems are fundamentally the same as galvanic anode systems in their operation, except that in impressed current systems a rectifier or other direct current power source is used to increase the potential of the electrons from the anodes to provide the desired protective current. Thus, shown in figure, in the addition to an anode and a connection to the structure is being protected, an impressed current cathodic protection system uses a rectifier or other power source. A battery, solar cell, direct current generator or thermoelectric generator may be used as a power source. However, nearly all impressed current cathodic protection systems use alternating current or solar powered rectifiers as a power source.

### **3.2 Impressed Current Rectifier:**

Rectifiers used for cathodic protection systems commonly used an adjustable step down transformer, rectifier stacks, a shunt to measure output current, meters to indicate output current and voltage, circuit breakers, lightning arresters, and transformer tap connections, all in one case. The function of the rectifier is to convert alternating current into controlled direct (pulsating) current.

### **3.3 Impressed Current Anode Materials:**

The anode of an impressed current system provide the means for the protective current to enter the electrolyte. Since the anode from the corroding part of the system, the best material is one that has a low rate of weight loss per ampere-year. The most commonly material used for impressed current anodes are Graphite and high –silicon cast iron. Aluminum is sometimes used in water storage tanks. In areas where heavy icing is not a problem, high silicon cast iron anodes



are used instead of aluminum for lower long term cost. Platinum coated titanium or niobium anodes and mixed metal oxide anodes are becoming more prevalent as impressed current anode material.

Before the 1970's there were only three types of anodes primarily used for impressed current ground beds high silicon cast iron. Graphite and scarp steel. As technology progressed, so did the type of materials that are commonly used by corrosion personnel. The materials have specialized applications and, when installation and operating costs are assessed, very few anodes can be used universally for any type of application and still achieve a desirable design life. In most soils, anodes evolve oxygen and the anode oxidizes as the current is discharged . in chloride containing soils or water , anodes evolve chlorine gas that forms hydrochloric acid, and the anode break down chemically. The whole purpose of this explanation is to point out that some anodes perform well in the presence of oxygen and others in the presence of acids.

### **3.3.1 High Silicon Cast Iron**

Cast iron anodes are produced in two alloys type with the principal addition of chromium, developed in 1959, to improve the life in chloride soils and water. Table shows the metallurgical composition of the two alloys. The principal reason for superior cast iron performance is the formation of a silicon oxide ( $\text{SiO}_2$ ) film that forms on the anode surface, reducing the rate of oxidation, and retarding the consumption rate. They have good electrical properties, and the resistance of the alloy is 72 micro-ohms per cubic centimeter at  $20^{\circ}\text{C}$ . to be successful in soils, the anodes are backfilled with metallurgical or petroleum coke breeze to reduce the anode resistance and increase the effective anode surface area. Even when the anodes are pre- packaged in coke breeze filled in canisters, filling the annular space between the canister and the soil with additional coke breeze is a recommended practice. In seawater, the anode will discharge current at very low voltages and therefore does not require backfill . Manufacturers of cast iron anodes developed cable to anode connection procedure little change in resistance with time, unless the anode is damaged. The high tensile strength of the metal is an asset in some circumstances,



except their very low elongation makes them brittle and subjected to fracture from severe mechanical and thermal shock.

Cast iron anodes are manufactured in a wide variety of dimensions, shapes and weights. Refer to Table 2-13 for a description for the various sizes. A proprietary type of cast iron anode, originally manufactured from “off-specification” corrosion resistance piping, is called a tubular anode. This uses the ASTM 518 Grade 2 chromium alloy and has demonstrated since 1971 to have superior to “end effect,” common to anodes with poor connection resistance values.

### **3.3.2 Graphite Anodes:**

Graphite rods have been used as an impressed current material for many years. The basic configurations consist of round or square rods, manufactured from slurry of powdered petroleum coke and coal tar resin. The coal tar is used as a bonding agent to hold the graphite particles together and then baked for a month at high temperatures to fuse the mixture. This process increases the resistance to oxidation and subsequent breakdown. There are many types of graphite compositions and the types used for cathodic protection ground beds is one of the most porous. The porosity allows moisture penetration to eventually migrate to the connection, causing failure at the cable connection. This led to varying procedures and numerous failures attributable to poor material, poor workmanship, and no quality control parameters prior to shipment. Many users have developed their own assembly standards that make graphite anodes a customized and consequently, more expensive product than it could be if an industry standard existed. Additional specification details should include:

- Type of container – lead, brass, molten, compression.
- Connection depth/diameter – 76mm (3 in), 102mm(4 in), 127mm(5 in), centered.
- Connection sealant – thermoplastic, thermosetting (epoxy).
- Cable sealant –TFE tubing, shrink cap, encapsulation.
- Impregnation - wax, linseed oil, resin.
- Sizes- 3”x30”, 3”x60”, 4”x40”, 4”x80”.





Graphite should not be operated at current densities exceeding 10.76 amperes per square meter (1 amperes per square foot) in soil or 2.70 amperes per square meter (0.25 amperes per square foot ) in water. Unfortunately, graphite is brittle and may be easily damaged during transportation , either bare or packaged. Special handling and padding is necessary to prevent cracking and breaking.

### **3.3.3 Aluminum Anodes:**

Occasionally, aluminum is used as and impressed current anode for protecting the interior of water tanks. Because it is relatively inexpensive compared to other impressed current materials, anodes are provided in ½-inch-diameter by ten-foot long screwed-rod sections. These are for use in tanks where seasonal icing usually destroys the anode lead wire connection, requiring annual replacement.

## **3.4 Types of Impressed Current Anode Beds:**

The types of impressed current anode beds are dependent on the placement, orientation, and depth of the anodes. Impressed current anode beds are normally placed in remote earth, and distribute current over long distances of the protected structure (pipelines, tank farms, distribution systems etc.). Distributed impressed current ground beds are sometimes used for small structures (valves, tanks),and the anodes are evenly distributed along the structure to be protected, each anode protecting a small portion of the whole structure. Distributed impressed current systems are commonly used to protect the interiors of water storage tanks, both ground level and elevated structures.

### **3.4.1 Vertical Remote Impressed Current CP Systems:**

These systems are commonly used for pipelines in remote areas. This is usually the most economical choice when there are not other utilities in the area and there is sufficient room to locate the anodes remote from the structure. Vertical placement of the anodes in the earth tends to lower the total resistance to earth of the system (versus horizontal). The distance to remote earth varies according to the resistivity of the earth, usually 91 to 213 meters (300 to 700 feet). Soil resistivity testing should be done in the area of a proposed anode bed to locate an area of



low resistance to place the anodes. Care must be taken to ensure that that low resistance area is not continuous to the protected structure.

### **3.4.2 Horizontal Remote Impressed Current CP Systems:**

These systems are commonly used for pipelines in remote areas where a rock stratum is located near the surface or where other soil conditions would require horizontal installation to ensure the anode is in a uniform environment. This is usually the most economical choice when there are not other utilities in the area, there is sufficient room to locate the anodes remote from the structure, and there is a rock stratum near the surface. Horizontal placement of the anodes in the earth tends to raise the total resistance to earth of the system (versus vertical). The distance to remote earth varies according to the resistivity of the earth, usually 91 to 213 meters (300 to 700 feet). Soil resistivity testing can be done in the area of a proposed anode bed to locate an area of low resistance to place the anodes. Care must be taken to ensure that the low resistance area is not continuous to the protected structure. Poor current distribution may occur if this condition occurs. In some cases, the best location for an anode bed may be in higher resistivity earth. The resistance of the anode bed can be lowered by adding additional anodes, using longer anodes, or by increasing the spacing of the anodes. The anodes may have individual leads connected to a header cable or they may be installed on a continuous cable.

### **3.4.3 Distributed Impressed Current CP Systems:**

These systems are commonly used to protect small structures. This is usually the most economical choice when structure is small or the anodes cannot be placed in remote earth. This type of anode bed is used to protect water tank interiors, ground level tank bottoms, underground storage tanks, or a short pipeline. Anodes are distributed along the pipeline, or around the surface of the tank (interior for water tanks, exterior for underground tanks). The distance from the structure is normally 1.5 to 3 meters (5 to 10 feet). In some cases, the anode is continuous, and is placed in a grid pattern on tanks, or along the side of a pipeline.

### **3.4.4 Deep Remote Impressed Current CP Systems:**



These are commonly used to protect large structures in built up areas. This is usually the most economical systems choice when the structure is large, in an area with many other utilities, or the anodes cannot be placed near the surface. This type of anode bed is used to protect pipeline distribution systems, aboveground tank farms, and pipelines in built-up areas. The anodes are placed in remote earth by drilling deep below the surface. The typical deep anode bed is 30.5 meters (100 feet) to the top anode, and from 61 to 183 meters (200 to 600 feet) to the bottom anode. The anodes can be on individual leads, spaced on a continuous cable, or be a continuous anode wire. This type of anode bed can have a much higher current capacity than typical surface anode systems. This type of system minimizes interference to other metallic structures. This system requires special consideration for backfill, cable insulation, and venting.

### **3.5 ADVANTAGE AND DISADVANTAGE OF IMPRESSED CURRENT SYSTEMS:**

#### **Advantage:**

- Economically feasible when installed on existing structures.
- Large voltage available (potential difference limited only by the size of power supply).
- Large current available, even in very high resistivity electrolytes.
- Can provide sufficient current to protect very large, poorly coated, or uncoated structures.
- Economically feasible to replace anode system when required.

#### **Disadvantage:**

- Significant operation and maintenance requirements.
- Relatively large chance of premature failure or breakdown.
- Possibility of stray current causing interference damage to other metallic (foreign) structures.

#### **Impressed current Test Stations**

Test station for structure with impressed current cathodic protection systems normally are merely contacts points for the positive connection of a voltmeter to allow for potential testing. Normally,

there are two wires to the two test station to permit test lead verification and redundancy. Also, impressed current systems require the same with a higher likelihood for interference bonds. Any location where the structure is assessable could be considered a test station.

### 3.6 ICCP Anode material

The permanent cathodic protection will have mixed metal oxide (MMO) strip also known as LIDA single. The LIDA single anodes shall be center connected sealed tabular type. These anodes shall be of noble metals. Mixed metal oxide coated titanium (having Ti substrate composition conforming to ASTM B338 Grade –I and Grade -II). The LIDA anode shall be dimensionally stable. The characteristic of anode single bed are as follows.

**Table 3.1: characteristic of anode single bed**

|  |   |
|--|---|
| Shape and dimension                                    | 1000 mm(+) or (-) 5mm long<br>25 mm (+)or (-) 1mm wide<br>3mm(+) or (-)mm thick |
| Weight   | 0.27 Kgs (+) or (-) 0.020 Kgs   |
| Operating current density (with Carbonaceous Backfill) | 75 Amp/m <sup>2</sup>   |
| Current output (with Carbonaceous Backfill)            | 3 Amp/m <sup>2</sup>  |
| Electrical Resistivity                                 | 6 X 10 <sup>(-5)</sup> Ohm cms  |
| Contact Resistance of anode to cable joint             | 9 X 10 <sup>(-5)</sup> Ohm (maximum)  |
| MMO Coating thickness                                  | < 6 gms/m <sup>2</sup>  |
| Anode Consumption Rate                                 | 1 mg/amp.yr   |
| Type and length of cable                               | XLPE PVC & As required to reach JB  |
| Design Life  | 40 Years  |

The anode to be installed at a distance of 5m (minimum) apart and shall be electronically remote to the pipeline (to be ascertained by calculations). Normally the nearest part of anode fir shallow horizontal/vertical type of anode beds shall not be less than 10m from the pipeline. However, the actual distance will be as per site conditions. For deep well anode the first anode should be at



least more than 15m deep and the actual depth shall be as per Approved design. However, for deep well anode bed instead of LIDA single anode LIDA string anode shall be used.

Each anode to cable joint shall be tested for its electrical contact resistance and its value in ohm shall be recorded. First anode to cable joint shall be subjected to accelerated ageing test and destructive test to determine pull out strength of cable to anode joint as well as effectiveness of the joint insulation.

### **3.7 Ac operated auto/manual transformer rectifier unit:**

- The CP transformer Rectifier unit scheme for protection, monitoring, control metering and indication shall be designed to meet the requirements of this specification. The control shall be achieved using thyristors and fully solid state logic only.
- Transformer shall be double wound, air cooled type with an electrostatic shield between the windings. The transformer insulation shall be class F. the winding shall be based on maximum current density.
- Rectifiers shall be silicon type of approved make with adequate cooling arrangement and with moisture and humidity resistance finish. It shall be mounted on spindles or other suitable supports. It shall have configuration suitable for full wave rectification. Adequate filtering in the form of L-C filtering circuit shall be provided on output side to smoothen out the DC output to limit ripple content to less than 5% at rated output.
- The input and output rectifier shall be protective by fast acting fuses of suitable ratings. Lightning Arresters / surge suppressor shall also be provided across DC output terminals to protect the rectifier against the surges. Each diode and SCR shall be provided with suitable surge suppressor.



## CHAPTER 4                      CATHODIC PROTECTION DESIGN METHODOLOGY

### 4.1 Introduction cathodic protection design

Before deciding which type, galvanic or impressed current, cathodic protection system will be used and before the system is designed, certain preliminary data must be gathered.

#### **Physical dimensions of structure to be protected.**

One important element in designing a cathodic protection system is the structures physical dimensions (for example length, height, width and diameter). These data are used to calculate the surface Area to be protected. **Drawing of the structure to be protected.** The installation drawings must includes sizes, shapes, material type. And location of parts of the structure to be protected.

**Electrical isolation** If a structure must be protected by the cathodic system it must be electrically connected to the anode. Sometimes part of a structure or, systems are electrically isolated from each section of the system to another.

**Short Circuits** all short circuit must be eliminated from existing and new cathodic protection system. When updating new cathodic protection systems, eliminating short circuit would be necessary first step.

**Corrosion History of structures in the area.** Studying the corrosion history in the area can prove very helpful when designing a cathodic protection system. The study should reinforce prediction for corrosivity of a given structure and its environment; in addition, it may reveal abnormal conditions not otherwise suspected. Facilities personnel can be a good source of information for corrosion history.

**Electrolyte resistivity survey.** A structure corrosion rate is proportional to the electrolyte resistivity. Without cathodic protection, as electrolyte resistivity decreases more current is allowed to flow from the structure into the electrolyte; thus the decrease. As electrolyte resistance can be measured either in a Laboratory or at the site with the proper instruments, the



resistivity data will be used to calculate the sizes of anode and rectifier required in designing the cathodic protection system.

**Table 4.1 Corrosivity variation according to soil Resistivity**

| Soil Resistivity Range (Ohm-cm) | Corrosivity        |
|---------------------------------|--------------------|
| 0 to 2000                       | Severe             |
| 2000 to 10000                   | Moderate to severe |
| 10000 to 30000                  | Mild               |
| Above 30000                     | Not likely         |

**Electrolyte pH Survey.** Corrosion is also proportion to electrolyte pH. In general, steel's corrosion rate increases as pH decreases when soil resistivity remains constant.

**Structure versus electrolyte potential survey.** For exiting structures, the potential between the structure and the electrolyte will give a direct indication of the corrosivity. According to NACE Standard No. RP-01, the potential requirement for cathodic protection is negative (cathodic) potential of at least 0.85 volt as measured between the structure and a saturated copper-copper sulfate reference electrode in contact with the electrolyte. A potential which is less negative than -0.85 would probably be corrosive, with corrosivity increasing the negative value decreases (becomes more positive).

**Current requirement** A critical part of design calculation for the cathodic protection system on exiting structures is the amount of current required per square foot( called current density) to change the structure's potential to -0.85 volt. The current density required to shift the potential indicates the structures surface condition. A well coated structure (for example, a pipe line well coated with coal-tar epoxy) will require a very low current density (about 0.05 milli ampere per square foot); an uncoated structure would require high current density (about 10 milli amperes per square foot). The average current density required for cathodic protection can be determined in three ways.



- ❖ An actual test on existing structures using a temporary cathodic protection setup.
- ❖ A theoretical calculation based on coating efficiency.
- ❖ An estimate of current requirements using table based on field experience

(1). The second and third method above can be used on both existing and new structures.

(2). Current requirement can be calculated based on coating efficiency a current density (current per square foot) desired. The efficiency of the coating as supplied will have a direct effect on the total current requirement, as equation shows:

$$I = (A)(I_0)(1.0 - CE)$$

**Where, I is total protective current,**

**A is total structure surface area in square feet**

**$I_0$  is required current density, and**

**CE coating efficiency**

This equation may be used when a current requirement test is not possible, as on new structures, or as a check of the current requirement test on existing structures.

Coating efficiency is directly affected by the type of coating used and by quality control during coating application. The importance of coating efficiency is evident in the fact that a bare structure may require 100000 times as much current as would the same structure if it were self coated.

(3). Current requirements also can be estimated from table given. The table gives an estimate of current, in milli amperes per square foot. Required for complete cathodic protection. That value multiplied by the surface area of the structure to be protected (in square feet) Gives the total estimated current required. Cautions should be used when estimating, however, as under or overprotection may result.



**Table 4.2 Current Density of Different Environment**

| Environment                                      | Current density (mA/sq ft.) |          |
|--|-----------------------------|----------|
|  | AFM                         | General  |
| Neutral soil                                     | 0.4- 1.5                    | 0.4-1.5  |
| Well aerated neutral soil                        | 2-3                         | 2-3      |
| Wet soil   | 1 -6                        | 2.5-6    |
| Highly acid soil                                 | 3-15                        | 5-15     |
| Soil supporting active sulfate reducing bacteria | 6- 42                       | Up to 42 |
| Heated soil                                      | 3-25                        | 5-25     |
| Stationary fresh water                           | 1-6                         | 5        |
| Moving fresh water containing DO                 | 5-15                        | 5-15     |
| Seawater   | 3-10                        | 5-25     |

**Coating resistance** a coating resistance decreases greatly with age and directly affect structures-to-electrolyte resistance for design calculations. The coating manufacturers supply coating resistance values.

**Protective current required** . by knowing physical dimensions of the structure to be protected, the surface area can be calculated. The product of the surface area multiplied by current density obtained previously in I above gives the total current required.

#### **4.2 Methods of applying cathodic protection**

Cathodic protection may be achieved in either of two ways. By the use of an impressed current from an electrical source or by the use of sacrificial anodes (galvanic action).

##### **Impressed current**

The buried pipe receives current from a DC power source by an auxiliary inert electrode buried in the ground. The pipe becomes the cathodic and the auxiliary electrode the anode. The auxiliary electrode some time consist of scrap iron. In this the iron will dissolve from the anode by reaction(1) . And the electrode is describe as an consumable anode. If the anode is a noble metal or an electrochemically inert material, the surrounding environmental will be oxidized and in water reaction will occur. In saline solution, however, chlorine may be produce at the anode. This may be presents problems confined space.

A range of materials have been used as non consumable anode for impressed current systems. The sorts of properties required by these anode are:

- Good electrical conduction
- Low rate of corrosion
- Good mechanical properties, able to stand the stress which may be subjected to during installing and in service
- $2\text{H}_2\text{O} = \text{O}_2 + 4\text{H}^+ + 4\text{e}^-$
- Readily fabricated into a variety of shapes
- Low cost
- Able to with stand high current densities at their surface without forming resistive barrier oxide layer, etc.

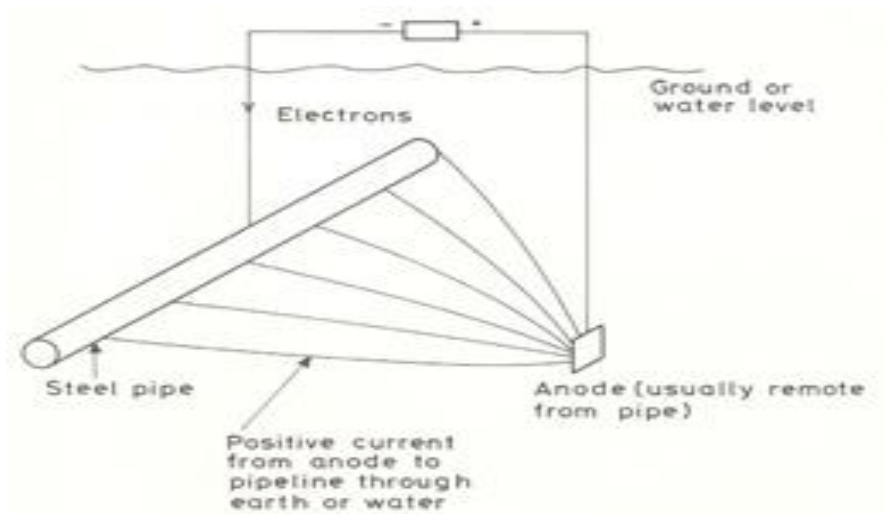

**Figure7: Application of cathodic protection by an impressed current**

**Reference: Cathodic protection P E Francis**

The following materials have been used as anodes: magnetics, carbonaceous materials (graphite), high silicon iron (14-18% Si), lead/lead oxide, lead alloys, and platinised materials (such as Niobium, titanium & tantalum). Platinum, with its high resistance to corrosion would be an ideal anode material but has the measure disadvantage of very high cost. In practice voltage up to 100 volt and high current densities are possible on impressed current anode (see table no 1.). Thus, large areas of a structure can be protected from a single anode and because of high driving voltage the anode can be placed remote from the structure.

**Table4.3 properties of impressed current anodes**

| <b>Anode Material</b> | <b>Max Volts*</b> | <b>Typical Anode Current Density A m<sup>-2</sup></b> |
|-----------------------|-------------------|---|
| Platinum/ niobium     | 100               | 250- 1500   |

|                         |     |          |
|-------------------------|-----|----------|
| Lead/ silver / antimony | 100 | 250-1000 |
| High silicon iron       | 100 | 10-100   |
| Graphite                | -   | 200      |

\*Dependent on environment

**Reference: Cathodic protection P E Francis**

### 4.3 Design

#### Protection potentials

In practice, the structure to electrolyte potential are measured using a standard reference electrode based on copper/ copper sulphate, silver/ silver chloride, or pure zinc. The reference electrode should be very close to the surface whose potential is being measured. For steel in an aerobic electrolyte of nearly natural pH a commonly accepted protection potential is -850 mV; when exposed to sulphate reducing bacteria a potential of -950 mV would be required. Both value are referred to a copper or copper sulphate electrode. Some potential value of protection of other metals are shown in table 4. Value for lead and aluminium must be carefully control to avoid damage by excess alkali, which could build up at the surface of the metals if the protection potential are to negative.

**Table 4.4 Potential required for cathodic protection**

| Metal                              | Potential ( Cu/CuSO <sub>4</sub> ) |
|------------------------------------|------------------------------------|
| Steel                              | -850 mV                            |
| Steel (sulphate reducing bacteria) | -950 mV                            |
| Copper alloys                      | -500 to -650 mV                    |
| Lead                               | -600 mV                            |
| Aluminium                          | -950 to -1200 mV                   |

**Reference: Cathodic protection P E Francis**

#### Current density



The current density required to maintain the protection potential is very dependent on local conditions. Increase availability of oxygen at the surface of the metal will directly increase current density. Increase availability of oxygen may occur because of increase concentration of oxygen in the environment, increase water flow or turbulence. Thus, current density to structure in sea-water, rivers e.t.c. are likely to vary continuously. The pH of environment will also be important, the presence of coating, marine fouling, calcareous deposits will have a profound effect on current density. Some typical value of current density for steel are shown in table no. 4.5.

**Table 4.5 Current densities required to protect steel**

| Environment     | Current density $A m^{-2}$ |
|-----------------|----------------------------|
| Acidic solution | 350 – 500                  |
| Saline solution | 0.3 – 10                   |
| Sea water       | 0.05- 0.15                 |
| Saline mud      | 0.025 – 0.05               |

**Reference: Cathodic protection P E Francis**

Having decided on the appropriate current density, the total anode current can be determined from the area of structure. The size of the anodes can then be determined from data in table no 3. If a sacrificial anode scheme is to be employed, taking into account the working life of protected a structure or the period required between refits.

### **Coating**

The provision of an insulating coating to the structure will greatly reduce the current demand for the cathodic protection. When first applied, coatings will often contain flaws, and in service, further defects will develop over a period of time. The conjoint use of coating and cathodic protection takes advantage of the most attractive features of each method of corrosion control. Thus, the bulk of the protection is provided by the coating and cathodic protection provides protection to flaws in the coatings. As the coating degrades with time, the activity of the



cathodic protection system develops to protect the deficiencies in the coating. A combination of coating and cathodic protection will normally result in the most economic protection system.

### **Calcareous Scales**

The seawater, cathodic protection of bare steel is economic because of the information of calcareous deposits. The alkali formed at the surface of a protected structure reacts with bicarbonate as insoluble calcium carbonate (reaction 4) on the surface of the metal.

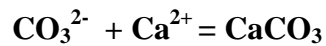
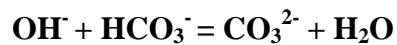

### **4.4 Design consideration**

Availability of data- A designer should first collect the data related to the structure to be cathodically protected. It can be collected after designing some format. Format may include following information:

- Proposed structure exist or yet to be built
- Pre-construction survey performed
- Structure design life
- Surface to be protected
- Material of construction
- Details of protecting coating
- Details of isolation
- Details of grounding
- Environment details
- Power availability
- Surrounding structure details
- Stray currents if any
- Safety consideration
- Electrical attenuations on structure



History of structure – if structure is yet on drawing board CP designer has more degree of freedom. Corrosion control measures incorporated at this stage are less costly and more reliable.

Structure design life – CP system deteriorate with user. For long service life structure CP should be designed for ready replacement and maintenance of component.

Surface to be protected – control of corrosion with cathodic protection is fundamentally is related to the current density applied to exposed metal surface. Pipelines and cables may exhibit significant attenuation in some environment. Data on the length of such structure must be available.

Material of construction – Al, lead etc. are alkali sensitive and may react unpredictably in alkaline environment produced by excessive cathodic protection current density. Titanium may produce hydrides ; high strength steel may be brittle if CP produced excessive hydrogen at the metal surface. Copper may get erode where water velocity is more than 1.5 m/sec.

Method of Fabrication – welding joint often has electrical resistance at the point of connection. A cumulative effect of the mechanical joint on the linear electrical resistance of long section of pipeline is an example.

Protective coating – A metal effectively covered by bonded dielectric protective coating require CP only at point of coating damages. An estimate of the effective coverage of a coating is important in developing a suitable CP design for coated structure.

Electrical/isolation/grounding – cathodic protection applied to an electrically isolated structure is far easier to design than protection for a structure that is not isolated or feasible for isolation. Requirement for surge protection, high potential hazard should be checked.

Environment – Environment transport CP current as well as define corrosion process. CP current requirement depends on chemistry, permeability, hydrodynamics and temperature of environment. Environment includes following:

- Resistivity
- Velocity
- Temperature
- Commercial power
- Other structures involves
- Presence of stray currents
- Fire or explosive hazards

#### **4.5 Steps in designing CP installation**

##### **Impressed current**

- Establish soil resistivity
- Estimate total current requirement
- Establish electrical continuity of structure
- Consider requirement for electrical isolation
- Consider the number & disposition of anode/ground bed
- Select suitable anode material
- Calculate Anode / ground bed size, shape, configurations
- Calculate circuit resistance & System for the most economical cable and total IR drop in the circuit
- Select rectifier voltage & current out put
- Design electrical circuit , fittings and switchgear
- Select location of CP test stations
- Consider facilities required for control monitoring
- Proper project drawing & specifications

#### **4.6 Impressed current cathodic protection system design:**

Thirteen steps are required when designing the impressed current cathodic protection systems.





**(1.) Review of soil resistivity.** As with galvanic system, this information will contribute to both design calculations and location of anode ground bed .

**(2.) Review of current requirement test.** The required current will be used through out the design calculations. The calculated current required to protect 1sqre foot of bare pipe should agree with the table above below.

### Select anode

As with the galvanic system choice of the anode is arbitrary at the same time economy will determine which anode is best. The anodes used most are made of high silicon chromium bearing cast –iron (HSCBSCI). Where impressed current cathodic protection systems are used to mitigate corrosion on an underground steel structure, the auxiliary anodes often surrounded by a carbonaceous backfill. Backfill material commonly used include coal coke breeze, calcined petroleum coke-breeze, and natural graphite particles.

**Table 4.6 Weight and dimensions of selected circular high silicon carbon bearing cast iron electrode**

| Anode weight (lb) | Anode dimension (inch) | Anode surface size (inch) | Package area (sq ft) |
|-------------------|------------------------|---------------------------|----------------------|
| 12                | 1 X 60                 | 1.4                       | 10 X 84              |
| 44                | 2 X 60                 | 2.6                       | 10 X 84              |
| 60                | 2 X 60                 | 2.8                       | 10 X 84              |
| 110               | 3 X 60                 | 4.0                       | 10 X 84              |

Calculate number of anodes needed to satisfy manufacturer’s current density limitations. Impressed current anodes are supplied with a recommended maximum current density. Higher current densities will reduce the anode life. To determine the number of anode needed to meet the current density limitations, use equation.



$$N = \frac{I}{(A1 I1)}$$

Where N is number of anodes required,

I is total protection current in milli ampere

A1 anode surface area in square feet per anode

I1 is recommended maxi current density output in milli ampere

Calculate number of anode to meet design life requirement. Equation is used to find out the number of anodes:

$$N = \frac{(L)(I)}{(1000)(W)}$$

Where N is number of anodes

L is life in years, and

W is weight of one anode in pounds

Calculate number of anodes meet maximum anode ground bed resistance requirements. Equation is used to calculate the number of anodes required :

$$Ra = \frac{\rho K}{NL} = \frac{\rho P}{S}$$

Where Ra is the anode resistance,

$\rho$  is soil resistivity in ohm- centimeters,

K is the anode shape factor from table

N is the number of anodes,

L is length of the anode back fill column in feet,

P is the paralleling factor from table,

S is the center to center spacing between anode backfill columns in feet.

**Table 4.7: Shape function (K)for impressed current cathodic anodes Where L is effective anode length & d is anode/backfill diameter**

| L/D | K      | L/D | K      |
|-----|--------|-----|--------|
| 5   | 0.0140 | 20  | 0.0213 |
| 6   | 0.0150 | 25  | 0.0224 |
| 7   | 0.0158 | 30  | 0.0234 |
| 8   | 0.0165 | 35  | 0.0242 |
| 9   | 0.0171 | 40  | 0.0249 |
| 10  | 0.0171 | 45  | 0.0255 |
| 12  | 0.0186 | 50  | 0.0261 |
| 14  | 0.0194 | 55  | 0.0266 |
| 16  | 0.0201 | 60  | 0.0270 |
| 28  | 0.0207 |     |        |

**Table4.8: Anode paralleling factors (F) for various numbers of anodes (N) installed in parallel**

| N | P       | N  | P       |
|---|---------|----|---------|
| 2 | 0.00261 | 14 | 0.00168 |
| 3 | 0.00289 | 16 | 0.00155 |
| 4 | 0.00283 | 18 | 0.00145 |
| 5 | 0.00268 | 20 | 0.00135 |
| 6 | 0.00252 | 22 | 0.00128 |
| 7 | 0.00237 | 24 | 0.00121 |
| 8 | 0.00224 | 26 | 0.00114 |
| 9 | 0.00212 | 28 | 0.00109 |



|    |         |    |         |
|----|---------|----|---------|
| 10 | 0.00201 | 30 | 0.00104 |
|----|---------|----|---------|

Select number of anode to be used. The highest number is calculated by equation, will be the number of anodes used.

Select area for placement of anode bed. The area with the lowest soil resistivity will be chosen to minimize anode to electrolyte resistance.

Determine total circuit resistance. The total circuit resistance will be used to calculate the rectifier size needed.

(a) Calculate anode resistance

(b) Calculate ground bed header cable resistance. The cable is typically supplied with a specified resistance in ohms per 100 feet. The wire resistance then is calculated.

$$R_w = \frac{\text{Ohms } (L)}{100 \text{ (ft)}}$$

Where L is the structure's length in feet.

Economics are important in choosing a cable, and many indeed be the controlling factor. To determine the total annual cable cost, kelvin's Economic Law can be used.

$$T = \frac{(0.0876)(I^2)(R)(L)(P)}{E} = (0.15) (S) (L)$$

Where T is total annual cost in dollars per year,

I is total protection current in amperes,

R is cable resistance in ohms per 1000 feet,

L is cable length in feet,



P is cost of electrical energy in farads per kilowatt-hour

S is the cable's initial cost in dollars per foot.

Calculate structure-to-electrolyte resistance using equation

$$R_c = \frac{R}{N} \quad \text{Where } R_c \text{ is the structure to electrolyte resistance,}$$

R is the coating resistance in ohms per square feet, and

N is the coated pipe area in square feet.

### **Calculate total circuit resistance.**

To calculate the total resistance,  $R_T$

$$R_T = R_a + R_w + R_c$$

Calculate rectifier voltage. Equation is used on the results of equation is used to determine voltage output ( $V_{rec}$ ) of the rectifier:

$$V_{rec} = (I) (R_T) (150\%)$$

**Where** I is total protection current in amperes,

$R_t$  is total circuit resistance, and 150 percentage is a factor to allow for aging of the rectifier stacks.

(11) Select a rectifier. A rectifier must be chosen based on the results of equation. Many rectifiers are available commercially; one that satisfies the minimum requirements of (I) and ( $V_{rec}$ ) in equation should be chosen. Besides the more, rectifiers being marketed, a solar cathodic protection power supply(for DC power) may be considered for remote sides with no external



power. Three factors that should be considered when specifying a solar cathodic protection power supply are:

- The cost of the solar cathodic protection system power supply in dollars per watt of continue power
- The solar cathodic protection power supplies much higher initial cost cooperated to selenium rectifiers operated by AC power.
- The additional maintenance require for a solar cathodic protection power supply. Mainly to keep the solar panel pre to dirt deposit.

(12) calculate system cost. As with the galvanic protection system, the choice of anode for design calculation is arbitrary. Where several anodes have been used in the design calculation, an economical analysis should be done as recommended in NACE standard RP/02.

(13) prepare plan in specification

## **4.7 Other requirement**

### **Types of electrical isolation to restrict spread of protective current**

- Electrical Earthlings
- Electrical Instrumentation
- Valves & scraper foundation
- Casings
- Foreign pipe line crossings
- Insulating coupling/ flanges

### **Cathodic protection potential criteria**

Cathodic protection criteria for steel and cast iron piping are given in NACE standard RP0169-96. It is reported as below.

- External corrosion control can be achieved at various levels of cathodic polarization depending on the environmental conditions. However, in the absence of specific data that demonstrate that accurate cathodic protection has been achieved one or more of the following shall apply:
- A negative(cathodic potential)of at least 850 mV with the cathodic protection applied. This potential is measured with respect to a saturated copper/ copper sulphate reference electrode contacting the electrolyte. Voltage drops other than those across the structure to electrolyte boundary must be consist for valid interpretation of this voltage measurement.
- A negative polarize of at least 850 mV relative to a saturated copper/ copper sulphate reference electrode.
- A minimum of 100 mV of cathodic polarization between the structure surface and a stable reference electrode contacting the electrolyte. The formation of decay of polarization can be measure to satisfy this certain.

### **Special conditions**

On bare or in efficiently coating pipelines where long line corrosion activity is of primary concern, the measurement of a net protective current at predetermined current discharge point from the electrolyte to the pie surface. As measured by an earth current technique, may be sufficient.

In sub situations, such as the presence of sulphide, bacteria, elevated temperature, acid environmental and dissimilar methods the certain mentioned at “1, 2, & 3” may not be sufficient.

### **Criteria four cathodic protection potential**

Cathodic protection system is generally design for pipe line considering following criteria.

- PSP between -0.95 & -1.5 volts with reference to Cu-CuSO<sub>4</sub> half cell bacteria.
- PSP between -0.90 & -1.1 volts with reference to Silver Chloride half cell.

- A -300 mV shift in “on” potential due to protective current.
- A -100 mV polarization decay between instantaneous of measurement and fully depolarization measurements.

With the relative cathodic protection system cycle on and off, any positive potential shift (with the system on) in excess of 20 mV (BS) or 100 (DIN) 100 milli volt will be investigated for interference.

The most important criteria is the design current density. The current density should preferably be determined on basis of experience. The design current density account for ageing of pipeline coating and thus increase in current density, as well as a security factor shall be incorporated.

#### **Choice of impressed current anode material**

- Ferrous material
- Carbonaceous material
- Platinised anodes
- Sintraceted anode
- Lead material

#### **Types of anode back fill**

- Carbonaceous bed fill coal coke breeze
- Calcined petroleum coke breeze

#### **Purpose of back fill**

- Anode effective size is process
- Transfer anode loss to bedding material
- Porous surrounding for gases skip
- More constant anode resistance

#### **Types of anode beds**



- Horizontal
- Vertical
- Deep coal anodes

### **Power source of cathodic protection**

Where an AC power supply exist and is reliable, transformer rectifier are the most economical source of DC for cathodic protection system, standard TR unit range varies in size from 5A, 5V to 100A , 48V for measure pipeline schemes. Where AC power supply do no exist or is not reliable than other source of power can be used like.

- DC diesel generator
- Gas generator
- Solar cells
- Wind generator
- PEG
- CCVT
- Fuel cell

## **4.8 Calculations**

Protective current is conducted into the soil by impressed current anodes, flows to the defects of the pipe coating and back to the protective rectifier via the pipeline. From the limits of the protective range towards the rectifier current flow increase steadily and causes a voltage drop along the pipeline. The value give the limiting length of the protective range a cathodic protection installing. At the limit of protecting range there must be either an insulating joint or next cathodic protection installing should become effective.

Allowing an of potential of minimum -1.150 Volt at the CP station and aiming to reach on off potential of max -0.85 volt at the limit of protective range, ego the mid point between two CP

stations or at an insulating joint, this corresponds to a maximum voltage drop he pipeline 0.3 volts.

### **Spread protection**

The formula for calculating spread of protection is given below

$$2L = \sqrt{(8*U_L) / (\pi*D*J*R)}$$

L= spread of protection(M) of one side of the cathodic protection station limited by an isolating joint or with arrangement acqui-distance to neighbour cathodic protection station.

$U_L = 0.3$  volt, maximum potential difference between potential at drain point ( $X=0$ ) and potential at and of protection spread ( $X= L$ ).

D = diameter of pipeline (m)

J = protection current density(A/m<sup>2</sup>)

R = resistance of pipe (ohm/m)

### **Voltage drop along the pipe**

The formula for calculating the voltage drop along the pipeline is given below

$$\Delta U = R*L (I + \Delta I / 2)$$

L= length of pipe line section(m).

R= resistance of pipe(ohm/m)

$\Delta I$  = current entering pipeline section over length L (A)

I= constant current in section A (A)

## Required protective current

The formula for calculating total current requirement from one CP station is given below

$$2I_0 = 2 \pi D J L$$

$I_0$  = protective current from one side the cathodic protection station (A)

D = diameter of pipeline (m)

J = protection current density(A/m<sup>2</sup>)

R = resistance of pipe (ohm/m)

L= spread of protection (m) one side of cathodic protection station, limited by an insulating joint or with arrangement acqui-distance to neighbour cathodic protection station. Curve showing the maximum protection range and the protective current demand as a function of the current density.

## Calculation of anode bed resistance

### Horizontal Anode beds

Horizontal anode beds calculating of anode bed resistance and voltage gradient perpendicular to the anode bed can be calculated from the formulas in annexure. Calculating of the voltage gradient on the longitudinal direction from the anode bed center can be calculated from annexure .The resistance of anode bed should be kept low in order to have a limited extension of anode gradient. Anode bed gradient shall be calculated to insure that over protection do not occur on the pipeline i.e. distance between anode bed and pipeline is sufficient. Similarly it shall be insure that secondary construction are located out side anode bed gradient field t6 above interference. The limit is normally where the normal bed gradient has decreased to 0.5 volt to remote earth.

### Vertical anode bed

Resistance of vertical anode beds and voltage gradient field from center of anode can be calculated. Requirement of resistance and voltage gradients for a vertical for a anode bed are



identical with requirements for the horizontal anode bed. Parallel coupling of vertical anodes can be calculated as given in annexure.

It is important to remark that lower resistance is achieved with a horizontal bed compared to vertical anodes, with the same numbers of anodes. This is due to the effect of the coke breeze in the horizontal anode bed, which can be assumed to act as an anode due to the low resistivity of coke breeze.

### **Calculation of anode life**

A galvanic anode useful life can be calculated when the following parameters are known.

Anode output current  $I$  (A)

Anode weight  $m$  (kg)

Efficiency  $E$  (%)

Capacity  $C$  (Ah/kg)

The lifetime  $L$  in hours can be calculated from

$$L = \frac{E \cdot C \cdot m}{I} \text{ (hours)}$$

As there are 8760 hours per year the life time in years shall be:

$$L = \frac{E \cdot C \cdot m}{I \cdot 8760} \text{ (hours)}$$

Following formula can be arrived from above for the life time of a magnesium and a Zinc anode:

$$\text{For Mg } E = 50\% \quad C = 2200 \text{ Ah/kg}$$

$$L_{\text{Mg}} = 0.13 \frac{m}{I} \text{ (Years)}$$

$$\text{For Zn } E = 90\% \quad C = 820 \text{ Ah/Kg}$$

$$L_{\text{Zn}} = 0.08 \frac{m}{I} \text{ (years)}$$

## **Galvanic anode current output**

The output current from a sacrificial anode can be calculated by Ohm's law as follows

$$I_a = V/R$$

$I_a$  = anode output current

$V$  = driving voltage

$R$  = circuit resistance

$V$  is the voltage difference between the potential of the cathodically protected surface and the potential of the anode. The circuit resistance comprises resistance of anode to earth, resistance of protected structure itself.

Normally only the resistance of anode to earth is considered as the other resistance can be neglected. However, with well-coated structures it may also be necessary to consider the resistance of the protected structure to earth.

## **4.9 Surveys & Measurements for CP Design**

### **Corrosion survey along pipeline route**

Basically, it is assumed that decision to install cathodic protection of planned structure taken either due to requirement of official regulations or as a result of investigations showing that a corrosive environment around the structure will prevail. Thus, the corrosion survey in this context comprises the investigations necessary in order to collect information required in the design of the cathodic protection system. The survey should be based on study of route maps and geological maps giving as much data as available.

The following should be located:

- Locations of other cathodically protected structures crossing or close to the pipeline route.

- Location of other stray current sources such as direct current traction system , welding equipment for similar other equipment.
- Location of high voltage electricity systems

By located sources which might create interference on the pipeline in due courses of time, it is possible either to re-route the pipeline or to take account for mitigation of the stray current source in the design of the cathodic protection system. Recording of high voltage electricity system in the vicinity of the pipeline is necessary to calculate the size of induced voltage on the pipeline. Necessary system data shall be collected from the electricity company. Furthermore, sufficient physical distance shall be observed o electricity stations, pylons earthing, etc.

#### **The following surveys can be made along the route**

- Measurement or evaluation of resistivity of pipeline environment
- Determine or evaluation of pH values of the environment where unusual chemical conditions are possible.
- Determine or evaluation of conditions suitable for anaerobic bacterial corrosion.

Resistivity measurement are normally made to identify suitable low resistivity environments for anode bed location. Determination of substantial change in the level of soil resistivity may lead to design of separate CP-systems for each soil resistivity area. Area with low pH values (acid environment) generally make it more difficult to polarize the pipe, implying that a higher current density in this area is required. This could be achieved by locating a CP- station near this area or by protecting the section individually. The presence of anaerobic conditions normally leads to the use of a protection potential criteria of -950 mV Vs. Cu-CuSO<sub>4</sub> instead of the standard criteria of -850 mV.

#### **Location Criteria Impressed current stations**

The location of the impressed current stations should be selected in order to fulfill the following aspects:

- Even distribution along the pipeline according to calculated spread of protection
- Availability of public electricity supply
- Good accessibility to station by car.
- Minimize risk of impact and vandalism of rectifier cabinet.
- Minimize disadvantages for land owners

### **Geo-electrical measurement**

The soil resistivity is very important parameter in the design of anode bed as it determines the anode bed leakage resistance. The soil resistivity should be as low as possible to minimize the construction costs of the anode bed, I.e. number and size of anodes, the extension of detrimental interference voltage gradients and the costs of power consumption. Therefore, low resistivity soils suitable for anode bed location should be identified by means of geo-electrical measurements performed in the area.

The geo-electrical measurements are normally carried out by means of “the Wenner Four Electrode Methods” which gives the average resistivity of the soil to a depth corresponding to the electrode spacing.

A generator provides an AC current flow between the two outside electrodes in the electrolyte. A corresponding voltage drop is measured between the two electrodes and by means of Ohm’s law. The soil resistivity can be found by putting value of R in given equation. The measurements in anode bed areas are normally made with an interval of 10 meters between two test points, with electrode placed in same line which the anode bed is indented laid.

### **Location of anode bed**

The location of anode bed should be selected in order to fulfill the following aspects:

- Low resistivity area for anode bed location ( $\ll 100 \text{ Ohm m}$ )
- Location in permanently humid, un drained environment.
- Distance between anode bed and pipeline sufficiently large to avoid overprotection ( $\ll 100 \text{ m}$ ).



- Distance between anode bed and secondary construction sufficiently large to avoid to interference.

### **Test Stations**

In order to monitor the cathodic protection efficiency, test stations are erected along the pipeline. the test stations are normally located beside or over the pipeline in the pipeline easement Zone. The following test stations can be used:

- Potential test stations
- Line current test stations
- Resistance test stations at all steel cased crossing and insulating couplings

In the stations, measuring cables “pin- brazed” welded to the pipe are terminated in a terminal board mounted with terminal jacks. To be able to check the “on” and “off” pipe to soil potentials, the potential test stations are normally located with an average interval of 1-2 km along the pipeline.

Every 3-5 km pipeline current test stations are normally established, allowing measurements of the current distribution in the pipeline. Line currents rest stations are mainly used to detect and located fault such as large coating damages and contact to secondary structures.

Resistance test stations are erected at steel cased crossing and underground insulating coupling to check for short circuiting of the coupling . Above ground insulating joints are usually equipped with metering jacks welded in both sides of the joints.

### **4.10 Dangers to be avoided**

Consideration must also be given to spark hazards created by the introduction of electric currents into structures situated in a hazardous atmosphere.





Any secondary structure residing in the same electrolyte receive and discharge the cathodic protection direct current by acting as an alternative low- resistance path. Corrosion will be accelerated on the secondary structure at any point where current is discharge to the electrolyte. This phenomenon is called “interaction”

Interaction may occur, for example , on a ship that is moored alongside a cathodically protected jetty, or on a pipeline or metal-sheathed cable that crosses a cathodically protected pipeline.

Interaction may be minimized by careful design of the cathodic protection system, in particular, by design of scheme to operate at the lowest possible current density and by maintaining the greater separation between the protected structure and the secondary structure, and between the ground beds or anodes and the secondary structure. It is an advantage of sacrificial anode schemes that they are not prone to creating severe interaction problems and therefore is popular for protection in congested and complex locations.

Methods and procedures are available for overcoming interaction, and testing must be carried out in the presence of all interested parties, so that the choice of remedial measures may be agreed if and when the acceptable limit of interaction is exceeded.



## CHAPTER 5

## DESIGN OF CATHODIC PROTECTION

Cathodic protection system is steel pipeline section in Mathura city GAS distribution system.

## **Permanent cathodic protection for Mathura city**

- Cathodic protection at cased crossings
- Cathodic protection for carrier pipe
- Data sheet for Zinc ribbon anode
- Inspection and test plan for zinc ribbon anode
- Standard drawing for CP system installing at cased crossing

### **5.1 Cathodic protection at cased crossing**

At cased crossing, casing pipeline shall be protected with additional protection. The casing shall be protected by means sacrificial anode at both end based on the calculation as tabulated below.

The permanent CP design [parameters.

Types of anodes (proposed) : Magnesium

Length of pre packed anode (proposed) : 1.5 mtrs

Length of bar anode(proposed) : 0.900 mtrs

Weight of each anode(proposed): 2.1 kg approximate

Diameter of pre packed anode(proposed): 0.15 mtrs

Diameter bare anode(proposed): 0.036 mtrs

For anode bed circuit resistance calculation, 1 number of anode considered in one bed.

### **5.2 Cathodic protection for carrier pipe**



Carrier pipe protection shall be provided for both coating and uncoated casing. Carrier pipe inside casing shall be protected by Zinc ribbon as per ASTM-B418-95A type II. The zinc ribbon anode shall be Termit connected to the outer surface of the bottom of carrier pipe extending up to clock hours hand position 4 & 8 ‘O’ clock. Anode to pipe joint shall be encapsulated using ‘M’ seal. Minimum one number of anode shall be installed between every two spacers (supports) provided between carrier and casing. Minimum number of ribbon anode installing required shall be given based on desired length as per design. Design calculation for zinc ribbon anode for carrier pipe protection are as under.

**Table 5.1: calculation of various parameters**

| Description                           | Crossing1 | Crossing 2 |
|---------------------------------------|-----------|------------|
| Carrier pipe dia (mm)                 | 203       | 203        |
| Carrier pipe length (m)               | 55        | 130        |
| Design life years                     | 35        | 35         |
| Pipe coating                          | PE        | PE         |
| Surface area (sq. mt)                 | 35.11     | 83         |
| Current density( $\mu$ A/ sq. Mt)     | 50        | 50         |
| Safety margin                         | 1.3       | 1.3        |
| Current required mA                   | 2.3       | 5.4        |
| Zn, anode Weight as per design Kgs    | 1.58      | 3.74       |
| Weight of anode per meter, kgs        | 0.78      | 0.78       |
| Total length of anode as per design m | 2.03      | 4.8        |
| Individual length of anode proposed   | 0.21      | 0.21       |
| Total length of anode proposed        | 5.67      | 13.65      |

### 5.3 Data sheet for Zinc Ribbon Anode

**Table 5.2: Data sheet for Zinc Ribbon Anode**

|    |  |                              |
|----|--|------------------------------|
| 1  | Manufacturer                                 | Platline Bros, USA           |
| 2  | Model  | Platt line                   |
| 3  | Type   | Type 2 ribbon anode type     |
| 4  | Shape  | Diamond shape ribbon anode   |
| 5  | Dimension                                    | 11.5 mm X15.5 mm (min)       |
| 6  | Standard coil length                         | 500 feet/coil                |
| 7  | Sheet core dia                               | 3.30 mm                      |
| 8  | Weight                                       | 0.850 kgsper meter           |
| 9  | Current capacity                             | 820 Amphr per kg             |
| 10 | Actual consumption                           | 11.25kgper Amp yr            |
| 11 | Chemical composition                         | Fresh water/soil application |
| 12 | Aluminium                                    | 0.005% max                   |
| 13 | Cadmium                                      | 0.003% max                   |
| 14 | Lead   | 0.003% max                   |
| 15 | Copper                                       | 0.002% max                   |
| 16 | Iron   | 0.0014%max                   |
| 17 | Zinc   | Balance                      |
| 18 | Open circuit potential wrt CuSO <sub>4</sub> | -1.05 to -1.1 V              |
| 19 | Efficiency                                   | 90%                          |
| 20 | Utilization                                  | 60%                          |

#### **5.4 Additional data to be collected**

The following data shall be collected to generate design data for evaluation of interaction interference possibilities due to presence of other services in ROW in close vicinity:

- i. route and types of foreign service under ground pipeline in and around or crossing the right of way (including those existing and those are which are likely to come up during contract execution or any abandoned pipelines).
- ii. Diameter , wall thickness, pressure, pipeline coating against corrosion, soil covered used in case of pipelines.
- iii. Details of the existing pipelines cathodic protection systems protecting the services I.e. . location, rating, type of protection, anode beds, test station locations and their connection schemes.
- iv. Graphical representation of existing structure/ pipe-to-soil potential [P-S-P] records, T/R unit current voltage input/ output rating, present current/ potential input/output data etc-for existing pipelines.
- v. Remedial measures exiting on foreign pipeline services to prevent, interaction.
- vi. Possibility of integration isolation of existing CP system, which may involve negotiations with owners of other ‘existing pipeline services.’
- vii. Crossing and parallel running of electrified non-electrified traction ‘(along with information regarding operating voltage, type AC/DC etc.) as well as abandoned tracks near ROW having electrical continuity with the tracks in use.
- viii. Crossing or parallel running of any HT AC/DC overhead line (11 KV & above) (existing/ proposed) along with details of distance from pipeline, voltage, type AC/DC, distance from pipeline of earthing of towers etc.
- ix. Voltage rating, number of cores and sheathing details of underground power cables along ROW or in its vicinity.
- x. Information on exiting and proposed DC/AC power sources and system having earth as return path, in the vicinity of the entire pipeline route such as HVDC sub stations fabrication yards with electric welding etc.
- xi. Any other relevant information that may be needed in designing and implementing proper protection scheme for the proposed GAIL pipeline.

## **5.5 Cathodic protection design parameters**



“Unless expressly varied and other wise specified in the project specification following parameters shall be used for design of permanent cathodic protection [PCP] system” those part of sacrificial anode cathodic protection [TCP] system which will be integrated with permanent CP system (PCP) such as reference Cu-CuSo<sub>4</sub> Electrodes, test lead points, junction boxes, Thermit welds epoxy encapsulation, markers, polarization coupons etc shall be designed based on permanent CP parameters.

Other parameters to be considered for [PCP] design

- Safety factor for current density 3
- Anode utilization factor ( 1.85 for Centre connected anode 0.5 for ribbon anode)
- Pipeline natural potential (-0.45)V [as measured from exiting upcoming structure in the same soil matrix.]
- Unless otherwise specified in project specification the design life of [TCP] temporary shall be 1 yea and that of [PCP] permanent CP shall be 35 years.
- Steel resistivity 202X(-7) ohm meter
- Maximum loop resistance 1ohm.
- 

## 5.6 Cathodic protection design criteria

### Permanent cathodic protection [PCP]

The pipe to soil potential measurement [PSP] shall be between (-) 0.85 V (off) minimum and (-) 1.18 V (off) maximum [both off potentials] with respect to CuCuSo<sub>4</sub> reference electrode in case sulfate reducing bacteria [SRB] are present.

### Permanent cathodic protection [PCP]

The [PCP] system may include the following major equipment sub system unless otherwise specified.

- Power source AC input DC output TRU with built in current interrupter.

- Distribution board
- MMO single anodes and anode ground beds in carbonaceous back-fill. In exceptional case with prior approval of GAEL LIDA string in deep well configuration.
- Test stations
- Computerized Test Stations
- Junction boxes with shunts and resistors
- Permanent reference Cu- CuSO<sub>4</sub> electrodes
- Pin brazing for pipe to cable connection [epoxy encapsulated]
- Surge diverter/ grounding cell across Insulation Mono- blocks
- Polarization cells at AC. Interference locations
- Interconnecting cables
- Cable to pipe connections. (pin brazing)
- Markers

### 5.7 Steps by step Design Calculation

Information Required: soil resistivity survey report, protective current density,

Anode consumption rate, life of individual anode, factor of safety, and length of section

Formula used:

No of Anode = Wt of total anode/ Wt of individual anode

$$\text{Total Wt of required anode} = \frac{(I \times C_t \times L)}{U_f}$$

Where, I is discharge current

C<sub>t</sub> is consumption rate of a anode in Kg per amp-year

L is life period of anode in year

U<sub>f</sub> is anode utilization factor

**Step 1: Surface Area =  $\Pi \times D \times L$**





Where D is diameter of pipe in mm

L is length of pipeline in m

The surface area calculation are tabulated as under:

| Pipeline section | Diameter (mm) | Pipeline length (meters) | Surface area (m <sup>2</sup> ) |
|------------------|---------------|--------------------------|--------------------------------|
| Main Line pipe   | 305           | 5600                     | 5363.12                        |
| Spur pipe        | 203           | 12300                    | 7844.24                        |

**Step 2: current required =  $S_a \times I_d \times 1.3 / 1000$  Amps**

Where

It is CP current requirement (amp)

Sa is surface area of pipeline (m<sup>2</sup>)

Id is CP Protective current density (mA/m<sup>2</sup>)

Safety margin is 1.3

| Pipeline section | Dia (mm) | Pipeline length (meters) | Surface area (m <sup>2</sup> ) | Protective current density (uA) | Current requirement (Amp) |
|------------------|----------|--------------------------|--------------------------------|---------------------------------|---------------------------|
|                  | 305      | 5600                     | 5363.12                        | 75                              | 0.52                      |
|                  | 203      | 12300                    | 7844.24                        | 75                              | 0.76                      |

**Step 3: Total anode requirement by Wt =  $\frac{(It \times Ca \times Y)}{Uf}$**

Where



W is total Anode Weight

$I_c$  is CP current requirement (amp)

$C_a$  is consumption rate of anode (7.9 Kg/ Amp- Year)

Y is design life in years

$U_f$  anode resistance utilization factor (0.85)

| Anode size (mm)  | Individual anode weight (kg) | Total anode requirement (Kg) | Total anode requirement (nos.) |
|------------------|------------------------------|------------------------------|--------------------------------|
| 36X36X900 mm (L) | 2.1                          | 11.9                         | 6                              |

#### Step 4: Number of anode required by ground bed resistance calculation

##### 4.1 Anode to earth resistance for multiple anode

$$R = 0.159p/NL (\ln (8L/D)-1 + 2L/S [\ln(0.656N)])$$

Where R= resistance to earth in ohms of the vertical anode in parallel

P = soil resistivity in ohms-m

N= number of anode in parallel (3 Nos)

L = Length of Prepackaged anode(1.50m)

D= Diameter of prepackaged anode (0.150m)

S= anode spacing in m (3 m)

A soil resistivity of 10 ohm-m has been considered for the purpose of sample calculation of the ground bed resistance. The magnesium anode shall have a cylindrical cross section of 36 mm diameter and a length of 900 mm and shall have a bare body of 2.1 Kg approximate excluding the weight of prepackaged in a cloth bag with a gypsum

bentonite sodium sulfate backfill mixture. The prepackaged anode shall have dimensions of 1.5m X 0.150m and the prepackaged wt. of 25 Kg.

Substitution all the above values in the equations a sample calculation for an anode bed with 3 nos. anode is as under.

$$R = 3.62 \text{ ohms}$$

#### 4.2 Anode to backfill resistance

$$R_v = 0.159 \rho/L (\ln(8L/D)) - 1$$

Where

$R_v$  = resistance of vertical anode to backfill in ohms (0.074)

$\rho$  = resistance of backfill material (0.5 ohm-m)

$l$  = length of anode in m (0.9m)

$d$  = diameter of anode in m(0.036m)

There for resistance of a single vertical anode to backfill is 0.074 ohms

#### 4.3 Cable resistance

For the ground bed using 3verticals anodes, the longest anode tail cable of 8m of PE insulation and stranded core copper conductor 6mm 2 cable shall be used. The cable resistance of copper conductor IC X 6mm2 size is 0.00308 ohm/m.

Therefore the cable resistance for 3 nos anode tail cables of 6 m length shall be

$$R_c = R_a \times L/N$$

Where

$R_c$  = total cable resistance

$R_a$  = cable resistance

$L$  = length of the cable

$N$  = no. of anodes

$R_c$  = 0.082 ohms

#### **4.4 total circuit resistance**

$$R_t = R + R_y/N + r_c$$

where  $R_c$  = resistance to electrolyte of ground bed (ohms)

$N$  = number of anode in each ground bed

$R_c$  = cable resistance

$R_t$  = 1.23 ohms

#### **STEP 5 Current delivering capacity of anode**

$$I_a = V_t / R_t$$

$I_a$  = current output per anode bed (amp)

$V_t$  = driving potential for Mg anodes (1.5-0.9) = 0.6 V

$R_t$  = total circuit resistance

$I$  = 0.49 A

Therefore the total current output per ground bed with 3 nos is 0.49A. similarly the following table gives the calculation for various anode bed configurations.



| <b>Soil Resistivity<br/>(ohm-cm)</b> | <b>Anode output<br/>current Amps/No<br/>of anodes (2.1 Kg)</b> | <b>Anode output<br/>current Amps/No<br/>of anodes (2.1 Kg)</b> | <b>Anode output<br/>current Amps/No<br/>of anodes (2.1 Kg)</b> |
|--------------------------------------|--|--|--|
|                                      | 1  | 2  | 3  |
| 2000                                 | 0.079  | 0.147  | 0.200  |

The anode ground bed locations and the number of anodes to be used for each location has been decided after taking into account. Various consideration like the current requirement for the respective spreads, the branch line requirement, soil resistivity data etc, an as tender specification

The change may vary a little bit as per actual site conditions at the time of selection of locations during installation.

As per soil resistivity data it is observed that soil resistivity value along ROW vary from 1 ohm-m to 163 ohm-m and at majority of the locations Average soil Resistivity value is in the range of 10 to 30 ohm-m. based on this we have considered 20 ohm-mtr for anode calculation.

As per the calculation the total requirement of anode by current , weight and resistance as follows.

Total current requirement 1.28 Amps

Total no of anode required by weight (using 2.1 Kg anode) : 6 nos

Total no of anode required by resistance (considering S. R 20 ohm-m) : 18 nos.

## **5 .8 design of main pipe line of MATHURA CGD**



### **GENERAL PIPELINE DETAILS:**

| <b>PIPELINE DETAILS</b> | <b>DIAMETER (Inch)</b> | <b>LENGTH (Km)</b> | <b>COATING</b> |
|-------------------------|------------------------|--------------------|----------------|
| Underground Pipeline    | 8                      | 2.3                | 3LPE           |
| Underground Pipeline    | 6                      | 38                 | 3LPE           |
| Underground Pipeline    | 4                      | 2                  | 3LPE           |

### **DESIGN DATA SHEET FOR IMPRESSED CURRENT CATHODIC PROTECTION**

Type of coating for the pipelines : 3LPE

- Type of CP system : Permanent Cathodic Protection
- Design life of protection : 25 years
- Design protection current density : 0.125 mA/m<sup>2</sup> (Considered Soil Resistivity < 10 Ωm)

Type of anode : MMO Coated Titanium Tubular Anode

- Cable to pipe connection : Thermit weld

### **RELATIONSHIP USED FOR RESISTIVITY CALCULATIONS**

Resistivity in ohm-mtrs =  $2 \times \pi \times S \times R$

Where:

S - Depth in mtrs. (Represented by spacing between electrodes)

R - Earth resistance in ohms

### **CATHODIC PROTECTION DESIGN CRITERIA**

#### **Permanent Cathodic Protection system :**

The pipe to soil potential measurements shall be between (-) 0.90V (OFF) to (-) 1.18V (OFF) for



Three Layer Poly Ethylene Coated pipeline w.r.t. Cu/ CuSO<sub>4</sub> type reference electrode.

In rare circumstances, a minimum polarisation shift of (-) 100 millivolts may be accepted as an adequate level of cathodic protection for the pipeline with the approval of owner.

## DESIGN CALCULATION

### For Permanent Cathodic Protection:

| Pipeline Details                         | Dia (m) | Length (m) | Surface Area (m <sup>2</sup> ) | Current Requirement (A) |
|--|---------|------------|--------------------------------|-------------------------|
| Underground Pipeline                     | 0.2032  | 2300       | 1467.51                        | 0.24                    |
| Underground Pipeline                     | 0.1524  | 38000      | 18184.37                       | 2.95                    |
| Underground Pipeline                     | 0.1016  | 2000       | 638.05                         | 0.10                    |
| Total Current Required                   |         |            |                                | 3.30                    |
| Number of TR Unit Required               |         |            |                                | 2                       |
| Rating of TR Unit                        |         |            |                                | 20V / 20A               |
| Number of Ground bed Required            |         |            |                                | 2                       |
| Number of anodes required per ground bed |         |            |                                | 6                       |

## SURGE DIVERTER FOR INSULATING JOINTS

For all the Insulating Joints provided on the pipeline one No. of Surge Diverter have to be provided.

The surge diverter when connected in parallel across the insulation joints shall have protect the insulating joint against surges coming across it due to lightning strikes, electrical faults, etc, on the above ground portion of the pipeline.

## **CABLE TO PIPE CONNECTION**

Cable to Pipe connections should be made by the Thermit weld method i.e. Exothermic Process by using Thermit weld metal powder poured in a Thermit mould. After the Thermit weld has been done, the exposed area should be completely covered with two-part epoxy. Coating shall be repaired after connection of cable conductor to pipeline.

## **MATERIAL DETAILS**

### **Impressed Current Anode:**

Anode : Mixed Metal Oxide Coated Titanium Tubular Anode

Dimension : 1" dia x 1000 mm Length

Cable : 1C x 10 mm<sup>2</sup>, PVC/PVC Insulated and Sheathed, Unarmoured

Canister : 200mm dia x 2000 mm Length

Current Output : 8 Amp.

Backfill : Coke Breeze

### **Junction Box:**

The Junction Box should be used in respective classified area with minimum degree of protection as

IP-55. The system design shall have the following types of Junction boxes:

- o Test Station
- o Anode Junction Box
- o Cathode Junction Box

All test stations shall have 20 % spare terminals, weather proof enclosure, having degree of





protection IP55 with hinged lockable shutter. Enclosure shall be made of sheet steel of 2.5 - 3 mm thickness and MS Post mounting.

**TR Unit:**

Input Power Supply : 240V, 50 Hz, single phase

Type : Oil Cooled, Manual Mode

Installation : Outdoor

Rating : 20V/20A DC

Enclosure : Sheet steel

Degree of Protection : IP-55

**Cables:**

| Cable Purpose  | Details   | Cable Size              |
|--|---|-------------------------|
| Potential Measurement cable – T/S  | Stranded Cu conductor, unarmoured, PVC insulated and PVC sheathed, Screened 650/1100 V grade. | 1C x 4 mm <sup>2</sup>  |
| TCP Anode Tail Cable   | Stranded Cu conductor, unarmoured, PVC insulated and PVC sheathed, Screened 650/1100 V grade. | 1C x 6 mm <sup>2</sup>  |
| Potential Measurement & Permanent Cu/CuSO <sub>4</sub> Reference cell connection cable | Stranded Cu conductor, unarmoured, PVC insulated and PVC sheathed, Screened 650/1100 V grade. | 1C x 6 mm <sup>2</sup>  |
| Current Measurement cable – T/S  | Stranded Cu conductor, unarmoured, PVC insulated and PVC sheathed, Screened 650/1100 V grade. | 1C x 10 mm <sup>2</sup> |
| PCP Anode Tail cable.  | Stranded Cu conductor, unarmoured, PVC insulated and PVC sheathed,                            | 1C x 10 mm <sup>2</sup> |



|   |   |                                |
|---|---|--------------------------------|
|   | Screened 650/1100 V grade.  |                                |
| Surge Diverter connection cable                                 | Stranded Cu conductor, unarmoured,<br>PVC insulated and PVC sheathed,<br>Screened 650/1100 V grade. | 1C x 25<br>mm <sup>2</sup>     |
| Negative & Positive header<br>cable<br>(Anode & Cathode) Cables | Stranded Cu conductor, unarmoured,<br>PVC insulated and PVC sheathed,<br>Screened 650/1100 V grade. | 1C x 35 mm <sup>2</sup>        |
| CJB at CP Station Cable   | Stranded Cu conductor, unarmoured,<br>PVC insulated and PVC sheathed,<br>Screened 650/1100 V grade. | 1Pair x 2.5<br>mm <sup>2</sup> |
| TR Unit Incomer Cable   | Stranded Cu conductor, unarmoured,<br>PVC insulated and PVC sheathed,<br>Screened 650/1100 V grade. | 3C x 10 mm <sup>2</sup>        |

**Permanent Reference Cell:**

High Purity Copper / Copper Sulphate reference cells with proven high reliability shall be provided

for stable pipe to soil potential measurement reference.

The reference cell for high resistivity areas shall be suitable for the prevailing dry soil conditions to give maximum service life. Permanent reference cells shall be installed with backfill material.

**Surge Diverter:**

Type : Spark gap

Spark over AC voltage at 50 HZ : 1 KV

Impulse (1.2/50 micro second) : 2.2 KV

**TENTATIVE BILL OF MATERIALS**

**Impressed Current Cathodic Protection:**

| Sr. No | Materials required  | Unit | Total |
|--------|---|------|-------|
| 1      | Corrosion Data collection   |      |       |
| A      | Soil Resistivity Survey at PCP anode ground bed Locations   | Loc. | 2     |
| B      | Design, Detailed Engineering for Permanent Cathodic Protection system.  | Ls   | 1     |
| C      | Supply and Installation of CP Materials   |      |       |
| 1      | Number of Groundbed   | Nos  | 2     |
| 1.1    | Shallow anode bed - MMO Coated Ti Tubular anode having current output of 8 Amps including coke breeze. (Canister size 200 x 2000 mm ) –<br>Number of Anodes per ground bed 6 Nos. | Nos  | 12    |
| 2      | TR unit (20V/20A)- Manual Mode, Oil Cooled  | Nos  | 2     |
| 3      | Permanent Cu/CuSO <sub>4</sub> Reference cell   | Nos  | 4     |
| 4      | Zinc Anode for foreign pipeline crossings   | Nos  | 3     |
| 5      | Junction Boxes:   |      |       |
| 5.1    | Anode Junction box (AJB): Constructed from sheet steel of 3 mm thick, lockable, Weather proof enclosure hinged door shutters and degree of protection IP-55.                      | Nos. | 2     |
| 5.2    | Cathode Junction box (CJB): Constructed from sheet steel of 3 mm thick, lockable, Weather proof enclosure hinged door shutters and degree of protection IP-55.                    | Nos. | 2     |

|     |  |      |     |
|-----|--|------|-----|
| 6   | Cables   | Mtr  |     |
| 6.1 | 1C x 10 sq.mm - Anode tail cable for PCP - (Single core, Cu Conductor, PVC Insulated and PVC Sheathed, unarmoured)   | Mtr  | 240 |
| 6.2 | 1C x 4 mm <sup>2</sup> - cables from P/L and Permanent Reference cells at CP stations. (Single core, Cu Conductor, PVC Insulated and PVC Sheathed, armoured) | Mtr  | 800 |
| 6.3 | 1C x 35 mm <sup>2</sup> - Anode and Cathode Header Cable (Single core, Cu Conductor, PVC Insulated and PVC Sheathed, armoured)                               | Mtr  | 500 |
| 6.4 | 1Pair x 2.5 mm <sup>2</sup> - cables from CJB at CP stations. (Cu Conductor, PVC Insulated and PVC Sheathed, armoured)                                       | Mtr  | 40  |
| 6.5 | 3C x 10 mm <sup>2</sup> - T/R Unit incomer Cable (Al Conductor, PVC Insulated, FRLS-PVC Sheathed, armoured)  | Mtr  | 25  |
| 7   | Cable to Pipe connection by Thermit Welding  | Nos. | 6   |
| D   | Testing and commissioning of CP System and as Built Documentation  | LS   | 1   |

**Note:**

1. The final Bill of quantities for major items required for installation are listed.
2. Rate provided is based on the above Bill of Quantity, any further item will be charged extra.



## CHAPTER 6

## CONCLUSION OF PROJECT

Corrosion leaks are of significant concern to OIL & GAS industry and it is considered to be the largest controllable factor in pipeline safety.

Cathodic protection is an electrical method of preventing corrosion. Since it is difficult and expensive to install conventional power lines in remote areas for supply of power to cathodic protection systems.

Solar powered CP systems are considered to be economical specially due to less maintenance requirement and very high reliability.

The present review of monitoring techniques indicates that at present two approaches are being developed in methods of cathodic protection effectiveness control.

On one hand traditional potential measurement methods and on the other hand electric and electrochemical measurement techniques are being developed.

This trend will be maintained in the nearest future as the applied measurement techniques are complementary and supplement each other in obtained information, ensuring better control of the quality of obtained anticorrosion protection of pipeline.

This gives requirement for the cathodic protection design, steps in installation and calculations required.

This describe weather the cathodic protection system design should be sacrificial or impressed.

Modern underground pipeline systems involves the use of good coating in combination with cathodic protection which minimizes the cost of protecting a structure.



## ANNEXURE

### Recommended Anode Utilization Factor for CP Design Calculation

| Anode Type   | Anode Utilization Factor |
|--|--------------------------|
| Long Slender Stand-off $L \geq 4r$   | 0.90                     |
| Short Slender Stand-off $L < 4r$   | 0.85                     |
| Long Flush mounted<br>$L \geq \text{width}$ and<br>$L \geq \text{Thickness}$ | 0.85                     |
| Short flush-mounted, bracelet, and other<br>Type                             | 0.80                     |

### TYPICAL GALVANIC ANODE MATERIALS AND CHARACTERISTICS

| TYPE      | ALLOY      | NOMINAL<br>CORROSION<br>POTENTIAL mv<br>vs..CSE | NOMINAL<br>CONSUMPTION<br>RATE kg/A-yr. |
|-----------|------------|---|---|
| Magnesium | ASTM B 843 |   |   |
| Mg/Mn     | MIC        | -1,750  | 8                                       |



|           |             |        |     |
|-----------|-------------|--------|-----|
| Mg/Al/Zn  | AZ31B       | -1,550 | 8   |
| Mg/Al/Zn  | AZ63B       | -1,550 | 7.9 |
| Zinc      | ASTM B 418  |        |     |
| Low Fe    | Type II     | -1,100 | 12  |
| Aluminium |             |        |     |
| Al/Bi/Sn  | Bismuth/Tin | -1,250 | 5.4 |



## **LIST OF FIGURES**

1. Cathodic protection of pipe using impressed current
2. Principle of cathodic protection
3. Corrosion cell/ bimetallic corrosion
4. Potential Gradient in cathodic protection
5. Cathodic protection process
6. Impressed current system
7. Application of cathodic protection by an impressed current



## **LIST OF TABLES**

Table1.1: Corrosion of steel in soil (Table A)

Table1.2: Types of carbon dioxide corrosion on steels ( Table B )

Table2.1 Steel pipe Resistance

Table3.1: characteristic of anode single bed

Table4.1 Corrosivity variation according to soil Resistivity

Table4.2 Current Density of Different Environment

Table4.3 properties of impressed current anodes

Table4.4 Potential required for cathodic protection

Table4.5 Current densities required to protect steel

Table4.6 Weight and dimensions of selected circular high silicon carbon bearing cast iron electrode

Table4.7: Shape function (K)for impressed current cathodic anodes Where L is effective anode length & d is anode/backfill diameter

Table4.8: Anode paralleling factors (F) for various numbers of anodes (N) installed in parallel

Table5.1: calculation of various parameters



## REFERENCES:

1. NACE RP0169-96 “control of external corrosion on underground submerged metallic piping system”
2. C.Dewaard and D.E Millians, “Carbonic acid corrosion of steel”, corrosion, vol. 31, 1975
3. C. Dewaard, U.Lotz and D.E Millians,”Predictive model for CO<sub>2</sub> corrosion Engineering in wet natural Gas pipeline”, corrosion, Vol. 47,1991
4. C. Dewaard, U.Lotz,”Predictive model for CO<sub>2</sub> corrosion of carbon steel”, corrosion 93, paper 69, 1993
5. C. Dewaard, U. Lotz and A. Dugstad “Influence of liquid flow velocity on CO<sub>2</sub> corrosion”, corrosion 95, 1995.
6. NACE MR0175-2000 “Sulfide stress cracking resistance materials for oil field equipment”.
7. “Peabody's control of pipeline corrosion ”, NACE, 2001
8. “Economics effect of metallic corrosion in the united states: 1995 update”, Battelle institute, 1996.
9. W. Beackmann, W. Schwenk, W. Prinz: Handbook of cathodic corrosion protection theory and practice of electromechanical protection process, Gulf, Houston 1997.
10. J. Morgan: Cathodic protection, 2eddition, NACE, Houston, 1978
11. R. Juchniewicz, J. Jankowski, K. Darowicki: Cathodic and anodic protection, in : corrosion and environmental degradation (M. Schutze, Ed.), Wiley- Vch, Weinheim 2000,Vol. I, pp.383470.
12. D. A Jones: Principles and prevention of corrosion, prentice hall, NJ 1996.
13. C. Wagner, W. Traud, Z. Elektrochem, 44, 391 (1938).
14. R. A. Gummow: The cathodic protection criterion for under ground steel structure proc. CORROSION/ 93, Paper no. 564 NACE, Neworleans 1993.
15. R. Juchniewicz, J. Jankowski, W. Sokolski, J. Walaszkowski: Criteria of cathodic protection of steel structure ( In polish), Ochrona przed korozja, 36,121 (1993 )



16. J. Kozłowski, W. Machezynski, Materaly XXIII Komwersatorion koroji Morskiej (In polish), Jurata 1999, pp 113-119.
17. B.A. Marthin, Proc. Cathodic protection theory and practice. Coference, paper no. 17 cobentry 1982.
18. B. Bazzoni, L. Lazzari: aaplication of extratolation techniquie for measurement of true potential, proc. EUROCORR 2000, London 2000.
19. J. Jankowski, A new approach to harmonic analysis, PROCEUROCORR. 98, Utrecht 1998
20. J. Jankowski: Application AC Electrochemical techniquie for corrosion rate Monitoring in cathodically protected systems, proc. EUROCORR. 99, AACHEN 1999.
21. NACE RP 160212 (National association of Corrosion Engineers)
22. Design of Cathodic protection systems, Department of Defence US Army.
23. DFR (Detailed Feasibility Report, Mathura City Gas Distribution)
24. CORROSION SCIENCE by Pea Body.



## **CALCULATION OF ANODE BEDS RESISTANCE AND VOLTAGE GRADIENT PERPENDICULAR TO THE ANODE BED**

### **HORIZONTAL ANODE BEDS**

Voltage gradient perpendicular to the middle of the anode bed.

## RESISTANCE OF VERTICAL ANODE BEDS AND VOLTAGE GRADIENT FIELD FROM ANODE

### VERTICAL ANODE

Voltage gradient from center of anode.

$$U_r = \frac{IQ}{2\pi l} \ln \left( \frac{t + l + \sqrt{r^2 + (t + l)}}{t + \sqrt{r + t}} \right)$$

L= anode length

d = anode diameter

t = Anode depth

$U_A$  = anode voltage

I = Anode current

R = Anode resistance to neutral earth

$U_r$  = The potential on the soil surface from center of anode





