

**MULTIOBJECTIVE OPTIMIZATION OF A
MULTINODAL
GAS PIPELINE**

By

ADARSH KUMAR ARYA

COLLEGE OF ENGINEERING STUDIES

Under the Guidance of

Dr. SHRIHARI HONWAD

Submitted



IN PARTIAL FULFILLMENT OF THE REQUIREMENT OF THE

DEGREE OF

DOCTOR OF PHILOSOPHY

TO

UNIVERSITY OF PETROLEUM AND ENERGY STUDIES

DEHRADUN

April, 2015

**MULTIOBJECTIVE OPTIMIZATION OF A MULTINODAL
GAS PIPELINE**

By

ADARSH KUMAR ARYA

COLLEGE OF ENGINEERING STUDIES

Under the Guidance of

Dr. SHRIHARI HONWAD

(CHEMICAL ENGINEERING DEPARTMENT)



Submitted

IN PARTIAL FULFILLMENT OF THE REQUIREMENT OF THE

DEGREE OF

DOCTOR OF PHILOSOPHY

TO

UNIVERSITY OF PETROLEUM AND ENERGY STUDIES

DEHRADUN

April, 2015

DECLARATION

I hereby declare that this submission is my own work and that, to the best of my knowledge and belief, it contains no material previously published or written by another person, nor material which has been accepted for the award of any other degree or diploma of the university or other institute of higher learning, except where due acknowledgment has been made in the text.

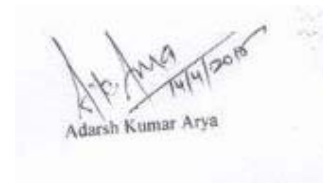

Adarsh Kumar Arya
14/4/2018

THESIS COMPLETION CERTIFICATE



This is to certify that the thesis entitled “*Multiobjective Optimization of a Multinodal Gas Pipeline*” submitted by *Adarsh Kumar Arya* to *University of Petroleum and Energy Studies* for the award of the degree of *Doctor of Philosophy* is a bonafide record of the research work carried out by him under my supervision and guidance. The content of the thesis, in full or parts has not been submitted to any other Institute or University for the award of any other degree or diploma.

Dr. Shrihari Honwad

The image shows a handwritten signature in blue ink on a light blue background. The signature is stylized and appears to be 'Dr. Shrihari Honwad'. Below the signature, the name 'Dr. Shrihari Honwad' is printed in a black, sans-serif font.

Place:

Date:

ACKNOWLEDGEMENT

I am thankful to all those persons, some of whom I even do not know in person, but whose efforts, directly or indirectly, facilitated me in completing the research.

To name a few, first I express my sincere thanks to my thesis supervisor, Dr. Shrihari Honwad for his great patience, help and discussions. Regardless of the day or hour, he was always willing to help and answer my queries. I am also grateful to several faculty members at UPES including Dr. Kamal Bansal, Dr. S.K. Gupta, Dr. Parichay K. Das, Dr. D.N. Saraf and others who offered their suggestions on my doctoral research work at various stages. I sincerely thank my critics whose suggestions always motivate me to do better research work.

I take the opportunity to acknowledge support from various industry experts, particularly-Shri V.K. Malhotra (Ex. GM, Pipeline Division, IOCL), Shri A.V. Rao (Ex. DGM, Pipeline Division, IOCL) and Shri K.K. Tandon (Ex. GM, Engineers India Limited, Presently Technical Director, Bhotika Pipelines) for giving valuable technical inputs. I am thankful to all current and previous UPES personnel, including Mr. Abhilash Dubey, Ms. Rakhi Ruhel and Dr. Aparna, whose administrative support helped my PhD work to reach a conclusive point. Last but not least, I sincerely thank my family members, particularly my parents, my brother, sister and all my well-wishers across the world who deserve my gratitude.

I am indebted to my wife Radha Arya for her loving support, encouragement and

understanding, not only in preparing this thesis but in everything I pursue.

Adarsh Kumar Arya

EXECUTIVE SUMMARY

Natural Gas is a sweeter source of energy present in abundant amounts (187.3 TCM) (Dudley, 2013). For transporting Natural Gas to very long distances, pipelines have been considered as the most economical, effective and safe mode as compared to other transportation methods. As the gas moves in pipeline network some of its pressure energy is lost due to friction, elevation and heat transfer between the gas and its surrounding. This necessitates boosting the pressure of gas that is achieved through compression of gas using compressors. The energy required to run compressors is obtained by the combustion of a part of natural gas being transported. The amount of natural gas consumed as fuel is immense and even a very small saving in fuel consumption can save considerable currency.

The fuel consumption in compressors approached a staggering half billion dollars per year in the United states alone & every 1% in fuel saving achieved can save up to 5 million dollars per year (Carter, 1996). Hence the objective of minimizing fuel consumption in compressors is of extreme importance. The objective of minimizing fuel consumption is achieved through various optimization techniques. Numerical simulation and optimization of gas pipeline can be of great help to design them, to predict their behavior and to control their operation. The thesis addresses the optimization process of gas pipeline networks. Ant Colony optimization (ACO)

algorithm which has not so far been applied to this system has been used for optimization. A framework for Modelling gas pipeline network similar to earlier works (Tabkhi, 2007) has been used with a modification that isentropic head and isentropic efficiency are a function of compression ratio instead of rotational speed.

Two different problems of Gas Pipeline Network have been analyzed.

Network 1: Single Source - Single Delivery Gas Pipeline Network System.

Problem 1: Single Objective function of Minimizing Fuel Consumption in Compressor at Fixed Throughput.

In this problem, an eighteen node network connecting a single source to a single delivery point has been analyzed. A steady state model, incorporating gas flow dynamics, compressor characteristics and mass balance equations have been developed. Ant colony, an evolutionary optimization technique has been used for minimizing fuel consumption for a fixed throughput. The optimum results obtained using Ant Colony Algorithm for forty five variables that includes pressure at nodes, mass rate in pipe arc, rotational speed of compressors, isentropic head across compressors and isentropic efficiency that lead to calculation of fuel consumption in compressors have been presented. Results have been compared with earlier work done using Generalized Reduced Gradient (GRG) Technique. Results show that utilizing Ant Colony optimization technique the fuel consumption is 0.738 kg per second while in Generalized Reduced Gradient it is 0.750 kg per second. In economic terms, this reduction would save 352,076.58 USD per year, assuming the cost of natural gas per kg is 0.74 USD.

Network 1: Single Source and Single Delivery Gas Pipeline Network System

Problem 2: Multiobjective problem of Minimizing Fuel Consumption and Maximizing Throughput at Delivery Station.

The Multiobjective problem of minimizing fuel consumption and maximizing throughput is another very interesting problem considered here. The algorithms that are used for solving multi-objective gas transportation problems are significantly different from the algorithms that are used for solving single objective optimization problems. Finding a Pareto front and non-dominated set of solution for nonlinear multi-objective optimization problem requires a significant computing effort. For solving the multi-objective problem, single objective ant-colony optimization algorithm has been combined with adaptive weighted sum method.

The non dominating sorting ant colony algorithm produces a set of Pareto Optimal Solution in the objective space of fuel consumption in compressors and throughput at the delivery station. Results show that the Pareto optimal solutions are not sensitive to the weights chosen as points for different weights are merging together.

Network 2: Multi Source and Multi Delivery Gas Pipeline Network System

Problem: Single Objective function of Minimizing Fuel Consumption in Compressor at Fixed Throughput.

This network forms a basis for Cross Country Pipeline Network as well as a City Gas Distribution Network. A forty five nodal gas pipeline network, consisting of six gas source stations, nineteen gas delivery terminals, seven compressors and ten valves have been analyzed. A steady state model, incorporating gas flow dynamics, compressor characteristics and mass balance equations have been developed. Optimized results of ninety eight variables

that include pressure at nodes, gas flow rate in pipe arcs, the amount of gas supplied from source stations to satisfy demand at delivery stations, gas flow rate through valves and fuel consumption in compressors have been presented.

Comparison of Ant Colony and GRG result show that utilizing Ant Colony optimization technique the fuel consumption is 0.36 kg per second while in Generalized Reduced Gradient it is 0.37 kg per second. In economic terms, this reduction would save around 630 thousand USD per year, assuming the cost of natural gas per kg is 0.74 USD.

Thus the technique of ant colony optimization has been developed and tested both for single source and single delivery gas pipeline network as well as multi source and multi delivery networks.

TABLE OF CONTENT

DECLARATION	i
THESIS COMPLETION CERTIFICATE.....	ii
ACKNOWLEDGEMENT	iii
EXECUTIVE SUMMARY	iv
TABLE OF CONTENT	vii
LIST OF FIGURES	x
LIST OF TABLES.....	xii
ABBREVIATIONS.....	xiii
1. INTRODUCTION	
1.1 Background.....	1
1.2 Representation of a Gas Pipeline Network System	3
1.3 Components of a Gas Pipeline Network System	6
1.4 Cost Components of a Gas Pipeline Network System.....	10
1.5 Motivation for the Research.....	11
1.6 Research Objectives.....	12
1.7 Thesis Outline	14
2. LITERATURE REVIEW	
2.1 Objectives of Gas Pipeline Optimization.....	16
2.2 Optimization Techniques	19
2.3 Application of Various Optimization Methods to Optimization of Gas Pipeline Networks	26
2.4 Analysis of the Literature.....	37
3. FORMULATION OF GAS PIPELINE NETWORK MODEL	
3.1 Modelling of Gas Pipeline	38

3.2 Modelling of Turbo Compressors.....	55
3.3 Modelling and Formulation of the Optimization Problems.....	60
3.3.1 Network 1: Network with Single Source and Single Delivery Station.....	60
Problem 1: Single-Objective Optimization.....	72
Problem 2: Multi-Objective Optimization.....	72
3.3.2. Network 2: Multi Source and Multi Delivery Pipeline Network System.....	74
Problem: Single Objective Optimization.....	87
3.4 Ant Colony Optimization.....	87
3.5 Chapter Summary	91
4. SINGLE SOURCE AND SINGLE DELIVERY PIPELINE NETWORK	
 OPTIMIZATION- RESULTS	
4.1 Single Objective Optimization Results.....	92
4.1.1 Ant Colony Results for Minimizing Fuel Consumption in Compressors for Fixed Throughput.....	92
4.1.2 Comparison of ACO results with GRG Results for Minimizing Fuel Consumption for Fixed Throughput	102
4.2 Multi-Objective Optimization Results.....	110
4.2.1 Comparison of Standard Test Problems (ZDT1, ZDT2 and ZDT3) Results and Ant Colony Results for validating Ant Colony Optimization Technique.....	112
4.2.2 Multi-Objective Ant Colony Results for Minimizing Fuel Consumption and Maximizing Throughput.....	116
4.3 Conclusion of Chapter	119
5. MULTI -SOURCE-MULTI- DELIVERY PIPELINE NETWORK	
 OPTIMIZATION- RESULTS	
5.1 Ant Colony Results for Minimizing Fuel Consumption in Compressors for Fixed Throughput.....	120
5.2 Comparison of Ant Colony and Generalized Reduced Gradient Results for Minimizing Fuel Consumption in Compressors for Fixed Throughput.....	130
5.3 Conclusion of Chapter	131

6. CONCLUSION AND PERSPECTIVES

6.1 Gas Pipeline Network Analysis	137
6.2 Conclusion	140
6.3 Recommendations and Future Work	142
Bibliography	144

SUPPORTING DOCUMENTS

Appendix A- Derivation of Pressure Drop Equation in Pipeline.....	150
Appendix B- Derivation of Average Gas Pressure Equation in Pipelines.....	158
Appendix C - Derivation of Gas Velocity Equation in Pipelines	161
Appendix D - Derivation of Isentropic Efficiency Equation of Compressors.....	164
Appendix E - Derivation of Fuel Consumed Equation in Compressors.....	168
Appendix F - Derivation of Surge Equation in Compressors	170

SUPPLEMENTARY TABLES

NETWORK 1

Supplementary Table 1: Density of Gas in Pipe Arcs	172
Supplementary Table 2: Average Pressure in Pipe Segments	174
Supplementary Table 3: Velocity of Gas in Pipe Segments.....	176
Supplementary Table 4: Compressibility Factor in Pipe Segments.....	178
Supplementary Table 5: Pressure Drop Equation in Pipe Arcs.....	180
Supplementary Table 6: Isentropic Head Across Compressors.....	182
Supplementary Table 7: Isentropic Efficiency of Compressors	183
Supplementary Table 8: Pressure Bounds on Pipe Arcs.....	184
Supplementary Table 9: Erosional Velocity in Pipe Arcs	186
Supplementary Table 10: Volumetric Flow Rate at Inlet of Compressors to avoid Chocking.....	188

NETWORK 2

Supplementary Table 11: Average Pressure in Pipe Segments	189
Supplementary Table 12: Compressibility Factor in Pipe Segments.....	192
Supplementary Table 13: Pressure Drop Equation in Pipe Arcs.....	195
Supplementary Table 14: Isentropic Head across Compressors.....	199
Supplementary Table 15: Isentropic Efficiency of Compressors	200
Supplementary Table 16: Fuel Consumption in Compressors	202
Supplementary Table 17: Erosional Velocity in Pipeline Segments	203

LIST OF FIGURES

Fig. 1.1a: Gun Barrel Gas Pipeline Network System	4
Fig. 1.1b: Tree Shaped Gas Pipeline Network System.....	4
Fig. 1.1c: Cyclic Gas Pipeline Network System.....	5
Fig. 3.1: Schematic Diagram of Turbo- Compressor used in Gas Pipeline.....	58
Fig. 3.2: Single - Source, Single - Delivery Pipeline Network System.....	62
Fig. 3.3: Multi-Source, Multi- Delivery Gas Pipeline Network System	76
Figures in Network 1 Results	
Fig. 4.1: Optimum Pressure Values at Eighteen Pipe Nodes obtained using ACO.....	96
Fig. 4.2: Optimum Gas Mass Rate in Fifteen Pipe Arcs obtained using ACO.....	97
Fig. 4.3: Optimum Rotational Speed of Six Compressors obtained using ACO.....	98
Fig. 4.4: Optimum Isentropic Head of Six Compressors obtained using ACO.....	99
Fig. 4.5: Optimum Isentropic Efficiency of Compressors obtained using ACO.....	100
Fig. 4.6: Minimum Fuel Consumption in Six Compressors obtained using ACO	101
Fig. 4.7: Comparison of Optimum Pressure Values at Eighteen Pressure Nodes obtained using (a) GRG and (b) ACO	104
Fig. 4.8: Comparison of Optimum Gas Mass Flow Rate in Fifteen Pipe Arcs obtained using (a) GRG and (b) ACO	105

Fig. 4.9: Comparison of Optimum Rotational Speed in Six Compressors obtained using (a) GRG and (b) ACO	106
Fig. 4.10: Comparison of Optimum Isentropic Head of Six Compressors obtained using (a) GRG and (b) ACO.....	107
Fig. 4.11: Comparison of Optimum Isentropic Efficiency of Six Compressors obtained using (a) GRG and (b) ACO	108
Fig. 4.12: Minimum Fuel Consumption in Six Compressors obtained using (a) GRG and (b) ACO.....	109
Fig. 4.13: Pareto Front of ZDT1 (a) obtained using Multiobjective Ant Colony Optimization (b) True Pareto Front.....	113
Fig. 4.14: Pareto Front of ZDT2 (a) obtained using Multiobjective Ant Colony Optimization (b) True Pareto Front.....	114
Fig. 4.15: Pareto Front of ZDT3 (a) obtained using Multiobjective Ant Colony Optimization (b) True Pareto Front.....	115
Fig. 4.16: Pareto Front of Single Source Single Delivery Gas Pipeline Network System for Different Weights obtained using Multiobjective Ant Colony Optimization Technique	118
Figures in Network 2 Results	
Fig. 5.1: Optimum Pressure Values at Forty Five Pipe Nodes obtained using ACO.	124
Fig. 5.2: Comparison of MOP and Average Pressure in Thirty Pipe Arc obtained using ACO.....	125
Fig. 5.3: Optimized Gas Mass Rate in Thirty Pipe Arcs obtained using ACO.....	126
Fig. 5.4: Comparison of Maximum Gas supply and Gas Supply obtained using ACO at Six Gas Source Stations	127
Fig. 5.5: Optimum Gas Mass Rate Values through Ten Valves obtained using ACO	128
Fig. 5.6: Fuel Consumption at Seven Compressors obtained using ACO	129
Fig. 5.7: Comparison of Optimum Pressure Values at Forty Five Pipe Nodes obtained using (a) GRG and (b) ACO	132
Fig. 5.8: Comparison of Gas flow rate in Thirty Pipe Arcs obtained using (a) GRG and (b) ACO	133
Fig. 5.9: Comparison of Mass Rate in Valves obtained using (a) GRG and (b) ACO.....	134

Fig. 5.10: Comparison of Gas Input at Six Gas Source Nodes obtained using (a) GRG and (b) ACO	135
Fig. 5.11: Comparison of Fuel Consumption in Six Compressors obtained using (a) GRG and (b) ACO	136

LIST OF TABLES

Table 1.1: Technical Features of Gas Pipeline System.....	8
Table 2.1: Summary of Work Done By Different Authors.	34
Table 3.1: Notation in Pipe Arcs.....	63
Table 3.2: Notation for Compressor Station.....	64
Table 3.3: Characteristics of Natural Gas moving in Network 1.....	65
Table 3.4: Prediction of fuel consumption for comparison of Tabkhi Model with our Model.....	71
Table 3.5 : Arc-wise List of Gas Pipeline Network.....	77
Table 3.6: Nodal Characteristics of Pipeline Network System	78
Table 3.7: Values of Maximum Supply and Minimum Delivery	79
Table 3.8: Principal Characteristics of the compressors	80
Table 3.9: Characteristics of Natural Gas moving in Network 2.....	81
Table 3.10: Ant Colony Algorithm for Single Objective Optimization	89
Table 3.11: Algorithm for Multiobjective Optimization	90

ABBREVIATIONS

Acronym	Meaning
A_c	Compressor Arc
c_i	Gas Sonic Velocity in Pipeline (m/s)
d_e	Density of gas (kg/m ³).
D	Diameter of Pipeline (m)
e	Absolute Roughness (m)
E	Efficiency of Pipeline (= 1, for seamless joint)
F	Factor of Safety (= 0.72, for cross country pipelines)
f	Friction factor (dimensionless)
G	Gas Gravity (dimensionless)
h	Isentropic Head Across Compressors (KJ/kg)
H_m	Heat Content of gas mixture (J/kg)
k	Isentropic Exponent.
L	Length of Pipe segment (m)
m	Mass flow rate in pipe arc (kg/s)
m_f	Mass of fuel consumed in compressors (kg/s)
M_s	Gas Supply Rate at Supply Stations (kg/s)
m_{de}	Gas Delivered at the delivery stations (kg/s)
M	Molecular Weight (kg/Mol).

$MAOP$	Maximum Allowable Operating Pressure (bar).
n_d	Driver Efficiency.
n_i	Adiabatic or Isentropic Efficiency.
n_m	Mechanical Efficiency.
n_p	Polytropic Exponent.
ω	Rotational speed of Compressor (rpm).
P	Pressure (bar).
P_b	Base Pressure (bar).
P_c	Critical Pressure (bar).
P_i	Suction Pressure at Compressor (bar).
P_j	Discharge Pressure of Compressor (bar).
P_{ij}	Average Pressure in Pipe Segment. ij (bar).
q	Volumetric Flow Rate (m^3/s).
Q_b	Volumetric Flow Rate of gas measured under standard conditions (m^3/s).
R	Gas Constant ($m^3.kPa/ k Mol. K$).
S	Specified Minimum Yield Stress (bar).
T	Temperature (K).
TCM	Trillion cubic meters = 10^7 lakh cubic meters
T'	Temperature Deration Factor (dimensionless).
T_b	Base Temperature (K).

T_c	Critical Temperature (K).
t_i	Thickness of pipeline (m).
V	Velocity of gas in Pipelines (m/s).
V_{ei}	Erosional Velocity of gas in pipelines (m/s).
Y	Mole fraction of individual component in gas mixture.
Z	Compressibility Factor

CHAPTER - 1

INTRODUCTION

1.1 Background

1.1.1 Natural Gas: An Outstanding Fossil Fuel

Fossil fuels are important non - renewable energy resources that have played a key role in the growth and development of human civilization. They can be classified into three categories: Coal, Petroleum and Natural Gas. Coal has been used since centuries for supporting technological progress in agriculture, manufacturing and transport. It has also been used as an energy source for electricity generation in power plants, steel manufacturing and cement production. In the twentieth century, oil superseded the position of coal, and has since then been an essential factor in sustaining our luxurious lifestyle. Nowadays, however, due to the continual and the indiscriminate increase in the oil price, coupled with a significant decline in oil reserves, as well as new environmental attitude expressed by various national governments about the existing high levels of air pollution, has led to the exploitation of a cleaner and more economically attractive fuel, *The Natural Gas*. The main component of Natural Gas is methane that is present approximately in the range of 70-90%. The other component of natural gas includes ethane, propane, butane, carbon dioxide, oxygen, nitrogen and traces of hydrogen sulfide. Natural gas is also called cleaner fuel due to low emission of greenhouse gases. Natural gas has proven to be a strategic commodity that augments current global energy supplies and, to some extent alleviates some of the possible consequences of using coal, petroleum and petroleum derivatives. Natural

Gas is a non-renewable energy resource that is expected to widely expand in the decades to come. The survey reveals that though Natural Gas is present in abundant amounts of about 187.3 TCM, its proper utilization can lead to its prolonged usage (Dudley, 2013). To make it possible, there is always a scope of improvement in design, processes and transportation. This has offered a number of challenges to the scientific research community.

1.1.2 Pipelines: An Excellent Transportation Mode of Natural Gas

Resources of natural gas are limited and have to be used efficiently. Natural gas is itself useless if it is not utilized and for this to happen, it needs to be transported to consumers through various transportation modes. For ages, roads, rail and sea have been an important foremost mode for transporting gas. However, for long distances, cross country pipelines have been considered as the most economical, effective and safest mode for transporting gas. The transportation of natural gas through pipelines has now become a very vital commercial activity and ensures 24*7 gas supply to consumers. Pipeline transportation, however, is very tricky business because it is expensive and its poor management can lead to bankruptcy. One must balance source and demand through proper routing, sequencing and maintaining optimal operating conditions of the equipment which is both expensive to maintain and run. The present thesis focuses on optimization of operating conditions for transporting natural gas through cross country pipelines.

1.2 Representation of a Gas Pipeline Network System

The state of the art on steady-state flow pipeline models reveals two fundamental types of network topologies, namely *Cyclic* and *Non-Cyclic*. Non-cyclic networks can be further classified into the gun barrel and tree shaped networks.

1.2.1 Gun barrel - Gas Pipeline Network

This type of network corresponds to a linear topology of pipeline and compressor network. The network has been shown in Figure 1.1a.

1.2.2 Tree Shaped - Gas Pipeline Network

This type of network also corresponds to a linear network, but contains branches. The network has been shown in Figure 1.1b.

1.2.3 Cyclic - Gas Pipeline Network

This corresponds to a network where between some pair of nodes there exists more than one path and each path contains at least one compressor. This type of Network is shown in Figure 1.1c.

In Figures 1.1a, 1.1b and 1.1c, a gray-gradient node shown with an incoming arrow represents a source node, a black node that is shown with an outgoing arrow represents a discharge node, and a white node is just a transshipment node.

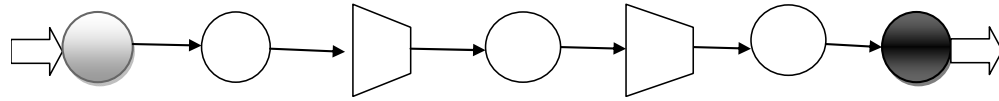

Figure 1.1a Gun Barrel Gas Pipeline Network System

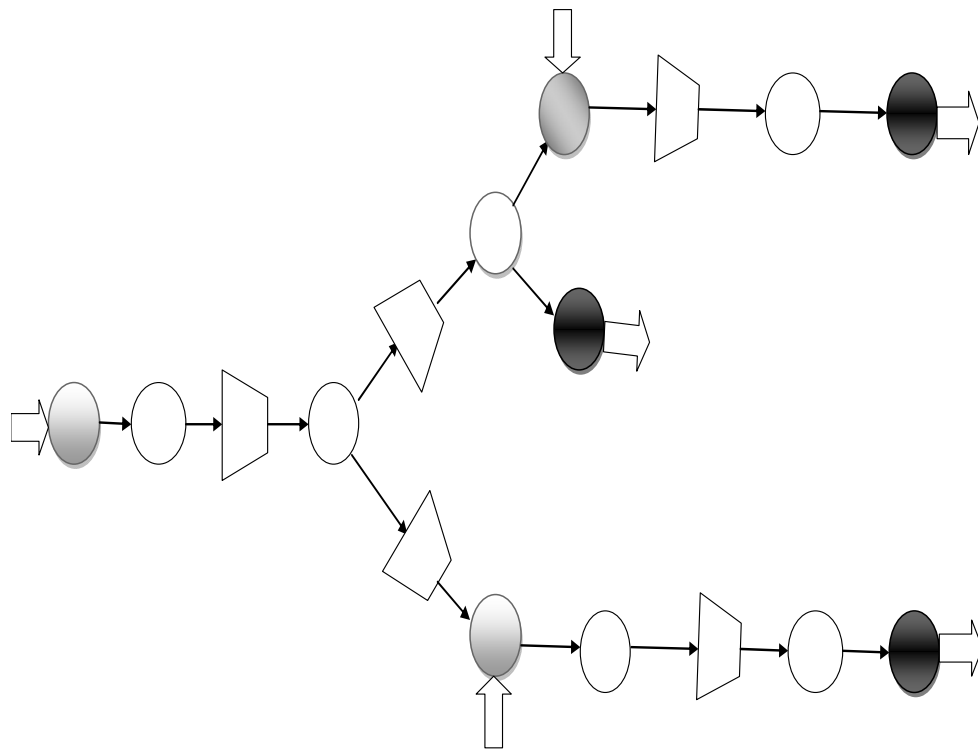

Figure 1.1b Tree Shaped Gas Pipeline Network System

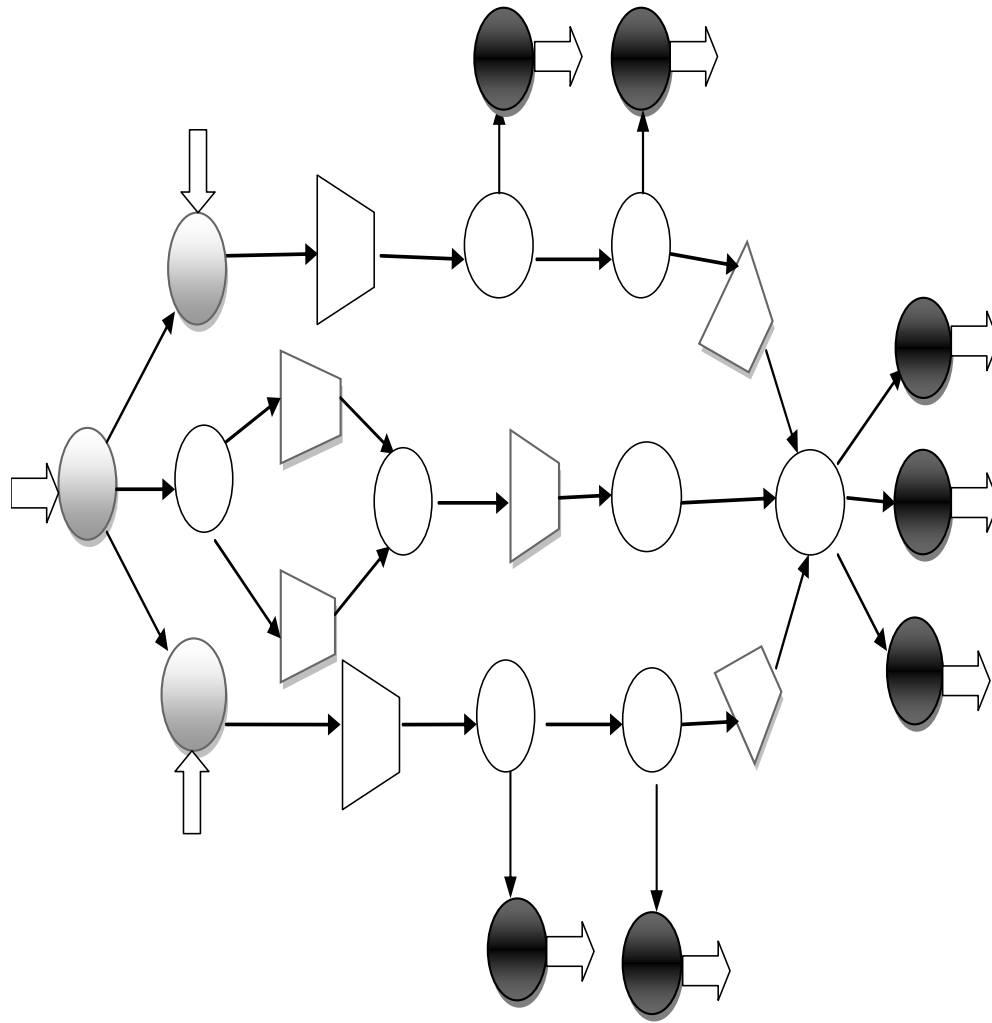

Fig. 1.1c Cyclic Gas Pipeline Network System

1.3 Components of a Gas Pipeline Network System

A wide variety of facilities and pieces of equipment operate together to transport and deliver the gas at the terminal station. Today a gas pipeline network consists of the following major components (Adeyanju, 2004):

- i. Inlet Station.
- ii. Compressor Stations.
- iii. Intermediate Delivery Stations.
- iv. Pipeline System.
- v. Valve Station.
- vi. Pigging Facility
- vii. City Gate Station

Brief discussion of each of the pipeline components has been given below.

i. Inlet Station

These stations are located at the beginning of the pipeline network system where gas is initially injected. Storage facility for storing the commodity, compressors for providing the initial pressure for the movement of the gas is installed at this station.

ii. Compressor Station

A compressor installed in a gas transmission pipeline network provides the necessary pressure that keeps the gas moving. Compressors that are installed at the inlet station to provide the necessary initial pressure are called *Originating Compressors* and that are located along the pipeline at intermediate locations are called *Booster Compressors*. A typical compressor station usually consists of several multiple

compressor units that may operate in series or parallel. In principle, longer is the pipeline and higher is the elevation of terrain crossed, the more is the compressor horsepower required to deliver the gas at desired pressure at the delivery station. However, for a fixed route and flow capacity, the number and size of booster stations can vary depending on circumstances and design. Although a pipeline network system with fewer stations is easier to operate, they have the disadvantage of introducing a need for high inlet pressures. The actual transmission system presents a compromise between a very few powerful originating station and a large number of small booster stations. In pipeline transportation system, *positive displacement* and *dynamic compressors* are the most widely used compressors.

iii. Intermediate Delivery Station

These facilities are provided at intermediate points in the pipeline. Purpose of installing these stations is to deliver part of natural gas, required by the consumer at intermediate locations.

iv. Pipeline System

In a pipeline network system, there can be pipelines ranging from few hundreds to thousands of kilometers. Depending on the application, these pipelines can be divided into different categories. Table 1.1 shows the different categories of pipelines and their technical features.

Table 1.1 Technical Features of Gas Pipeline System.

Pipeline Segment	Operating Pressure (bar)	Material used	Consumer Type
Natural Gas Production	> 65	Steel	Production Lines
High Pressure Gas Pipelines	< 65 but > 40	Steel	Large Power Plants using Natural gas as feedstock
Medium Pressure Gas Pipeline	< 40 but > 8	Steel	Chemical Industry, Ceramic Industry
Distribution Gas Pipeline	< 8	Steel, Cast Iron, PVC, PE	Offices, Domestic Users

v. Valve Station

Valves are constructed of steel, while following the specifications given by the standards of *the American Petroleum Institute (API)*, *American National Standard Institute (ANSI)*, and the purchaser's requirements. Mainline Valves and Blow down valves are the most common types of valves used in gas pipeline network system. Mainline Valves are installed in gas pipeline for hydro-testing and maintenance. These valves are also necessary to separate a section of pipeline and minimize gas loss that can occur due to pipe rupture. The spacing of these valves is decided on the basis of class location. Blowdown Valves are installed around the pipeline to evacuate gas from sections of pipeline in the event of emergency for the maintenance.

vi. Pigging Facility

These facilities utilize inspection gauge pigs to clean the inside surface of the pipeline and to monitor any rupture, leakage or anomaly that may exist in the pipeline.

vii. City Gate Station

These are the stations where transmission lines are connected to distribution lines. At these stations downstream pressure is reduced to match the pressure requirements of the distribution line. Main Control Unit, Remote Terminal Unit and SCADA (Supervisory Control and Data Acquisition) are the main components of City Gas Stations. *Main Control Room* is connected remotely with a large number of field devices, such as, flow, pressure and temperature transmitters, which are installed at specific locations. All data measured by these devices are gathered in a local *Remote Terminal Unit* and transferred in real time to the communication center via satellite channels and microwave links. At this center, a computer system known as SCADA is

used that monitors and controls all the processes. The SCADA system is a human machine interface that allows the operator to monitor the hydraulic conditions of the gas pipeline and execute commands such as open or close valves, turn on or off compressors, etc.

1.4 Cost Components of a Gas Pipeline Network System

In any pipeline system that is constructed to transport gas, there are capital and annual operating costs (Menon, 2005). These components are first discussed and then an equation for calculating 'Total Cost' is given.

i. Capital Cost

Capital costs are fixed onetime cost investment. Following are some of the major components of capital cost.

- (a) Installation cost, Material cost, Labor cost associated with pipeline and its auxiliary components.
- (b) Environment and Permitting Cost.
- (c) Right of Way Cost.
- (d) Engineering and Construction Management Cost.
- (e) Funds required during Construction and Contingency.

ii. Operating Cost

Once the pipeline, compressor stations and auxiliary facilities are constructed and put into operation there will be annual operating cost over the useful life of the pipeline.

The useful life of the pipeline is around 35 years, which can be further extended if proper maintenance is done. Operating cost includes the following major components:

- (a) Compressor Station Equipment Maintenance and Repair Cost.
- (b) Compressor Station Fuel Cost or Electric Energy Cost.
- (c) Pipeline, Valve, Regulator Maintenance Cost.
- (d) Utility Cost such as Water and Natural Gas.
- (e) Periodic Environmental and Permitting Costs.
- (f) Administration and Payroll Cost.

Total Cost of Pipeline is obtained by adding Capital Costs and Operating Costs.

$$\text{Total Cost of Pipeline Network} = \text{Capital Cost} + \text{Operating Cost}$$

1.5 Motivation for the Research

A very high investment is required in the design and operation of gas pipeline networks. Since the cost involved is very high, a very small improvement in gas pipeline network design or operations can save considerable currency. The trigger that motivates for this work is to minimize the huge operational cost of gas pipeline network that is achieved through optimization. Engineers have endeavored to save cost on pipelines through optimization of gas pipeline networks. The high saving involved in gas pipeline networks through optimization has also increased the interest of gas pipeline industries on the subject. However, optimization of gas pipeline networks is not an easy task. Involvement of the large number of variables with multiple objectives and many complex linear - nonlinear equality and inequality constraints makes difficult to find even the local optima. The problem involves two steps:

1. Modeling and Simulation.

2. Optimization

Simulation basically answers the question: what happens if the gas network grid runs with given control variables and known boundary conditions? Typical questions like finding a control regime which achieves several target values usually require a series of simulation runs by expert users who are familiar with the network. There are two disadvantages of numerical simulation. First, finding a feasible regime may take a large number of iterations and second it cannot guaranty that the solution obtained is optimal. This explains mainly why the searching process of optima must be guided with sophisticated optimization algorithms. The optimization of the multivariable system requires complex search algorithms. At every point the function needs to be evaluated which is done through simulation. The mathematical model used for simulation needs to be robust and so also the search. The analysis of the relevant literature which has been discussed in second chapter shows that there is a growing interest. Because of the number of variables involved, the task of establishing optimum can be quite difficult and in order to ensure a robust solution, many options may have to be investigated.

1.6 Research Objectives

The thesis attempt to solve both the theoretical and practical aspect of the gas transportation problem:

1.6.1 Theoretical Aspect

The present thesis aims at solving a number of objectives.

First, the idea is to develop a mathematical model, for the given pipeline network (Tabkhi, 2007), that meets the multiple thermodynamic and transport constraint to ensure quality of the solution. The steady-state model has been presented in detail in chapter 3.

Second, although various optimization techniques can be used, the evolutionary ant colony optimization technique has been chosen as it is generally recognized to be particularly well-fitted to take into account the multiobjective and multi-constraint problems.

Third, is to extend the single objective implementation to a multiobjective optimization problem.

The fourth is to apply the develop techniques for optimization of a more complex network.

1.6.2 Practical Aspect

The work presented here attempts to provide a general methodology and develop strategies in improving the operating conditions of the gas pipeline network problem.

The proposed strategy can be useful both to scientist and engineer engaged in design and process development and can help the gas network manager to answer the following recurrent questions in advance:

i. Knowing that the operator needs to deliver a certain volume of gas at certain key points, how must he utilize the compressors, most efficiently at his disposal so as to reduce gas consumption?

ii. Analyzing the effect of changing pressure and mass flow rate in gas consumption in pipeline network.

iii. Determining the characteristic values for compressor stations of some key parameters such as isentropic head, isentropic efficiency, rotational speed that are useful for the practitioner.

iv. Finally, the global framework can help decision making for optimizing the operating conditions of gas networks, anticipating the changes that may occur (i.e. gas quality, variation in gas source availability and consequences in maintenance) and quantifying CO₂ emissions.

1.7 Thesis Outline

This manuscript is now logically presented as follows:

Chapter 2 first presents the review of various optimization parameters in gas pipeline operation. Then a short description of the techniques used for pipeline optimization is presented and then finally the applications of optimization technique to optimize various objectives have been illustrated.

Chapter 3 presents the modeling equations of a gas pipeline network model. Two case studies, one for single source, single delivery gas pipeline network system and other of multisource multi-delivery pipeline network system has been presented. Further Algorithm for Single and Multiobjective Ant Colony Optimization technique has been presented.

Chapter 4 presents optimization results of Single and Multiobjective Optimization for Single Source, Single Delivery Gas Pipeline Network System.

Chapter 5 presents optimization results of Single objective optimization for a Multi-Source, Multi-Delivery Pipeline Network System.

Chapter 6 gives the conclusions and perspectives for future works.

CHAPTER -2

LITERATURE REVIEW

Optimization is a process of choosing the lesser of the evils. Apparently, the options need to be searched or identified and analyzed. The process parameters and their interactions, therefore, become very important to the process of optimization. The present chapter starts with review of scope of parameters involved in cross country gas pipelines and their mutual interactions. Further, the review of various techniques used for optimizing gas pipeline parameters has been presented. Finally the methodology adopted by different authors in solving various pipeline objectives is discussed.

2.1 Objectives of Gas Pipeline Optimization

2.1.1 Fuel Consumption Minimization

When gas moves in the pipeline, pressure energy of gas reduces due to friction of gas molecules with pipeline wall and heat transfer between the gas and surroundings. This necessitates the need of boosting the pressure of the gas. Compressors consume a small part of natural gas as fuel that is moving in the pipeline as an energy source. The more is the fuel consumption, more is the operational cost. The major amount of total natural gas consumption in pipeline network is consumed in compressor station (93%)

followed by electricity (4%), discharge end (2%) and heating (1%) (Marco, 2011). The fuel consumption in compressors approached a staggering half billion dollars per year in the United states alone & every 1% in fuel saving achieved can save up to 5 million dollars per year (Carter, 1996).

The flow rate and pressure at the delivery station are required to be maintained while ensuring minimal fuel consumption.

2.1.2 Fuel Cost Minimization

An alternative way of looking at fuel consumption minimization is minimizing fuel cost in compressors. A multi-supply and multi-delivery gas pipeline network may have several compressors installed to compensate for the pressure loss. However, for achieving certain throughput, only some of the compressors may be required to be switched on. Start up requires energy consumption, which again is obtained by burning part of the natural gas moving in the pipeline. The cost function incorporates the total fuel consumption cost in compressors that includes the start up cost also.

2.1.3 Optimal Configuration of Gas Transmission Networks

One of the objectives in the gas transmission network is to optimally design the pipeline network system by selecting appropriate devices and equipment units according to the technical - economic criterion. There are two main components of a gas pipeline network. One is pipeline and other is compressors. Determining the optimal diameter, optimal route of the gas pipeline, finding the optimal number of compressor units, location, design, pressure at the suction and discharge nodes of compressors are the various parameters that need to be evaluated. The objective is the

minimization of the investment cost of compressors and pipes or maximization of the net present value of the pipeline project.

2.1.4 Optimal Operating Conditions of Gas Networks

The number of variables involved and their complex interactions make this a very interesting problem. The operating conditions and other technical or economical parameters would define the dynamic feasibility of operations. They form the constraints or the objective function of the optimization process.

2.1.5 Throughput Maximization

The purpose is to determine the maximum amount of gas that can be transported to clients while satisfying supply, delivery and transport obligations. Mass flow rate of natural gas that is to be delivered at one or several nodes is taken as an objective function.

2.1.6 Profit Maximization

Another related problem to pipeline optimization is the determination of the optimal quantity of supply gas and deliveries in order to maximize profit while satisfying physical constraints. The fixed and operating costs which relate to the operating condition once again play an important role.

2.1.7 Power Maximization

From the energy point of view, the gas transported from the pipeline is the energy and hence power transported through pipelines. Now, since the power transmitted by the pipeline, is a linear function of throughput, its maximization means maximizing power.

2.1.8 Optimal Fortification Intensity for Natural Gas Pipeline Network

A gas pipeline network suffers heavy damages during natural disasters like earthquake, flooding etc. For years, researchers have been emphasizing on mitigating the effects of these disasters. For this reliability analysis is required for predicting seismic conditions. The model of optimal decision on fortification intensity for natural gas pipeline network takes into account the sum of the construction cost of natural gas pipeline network, the failure, loss expectation of the pipeline structure in future seism and the service loss that occurs after the disaster has occurred as a minimal objective function.

2.1.9 Least Gas Purchase Problem

Gas distribution companies are rarely affiliated with gas producing companies. Gas distributors have to purchase the gas from gas producing companies. For a gas distribution company one major problem is to minimize the cost of purchasing gas from the production companies. This problem is formulated as an optimization problem with linear objective function and nonlinear/non convex constraints.

2.2. Optimization Techniques

In section 2.1, a comprehensive discussion on various gas pipeline parameters that can be optimized in gas pipeline operations were presented. The present section reviews various optimization techniques that have been used to optimize gas pipeline parameters. The literature on optimization techniques can be grouped into two classes

– Classical and Stochastic methods. Most of the earlier work on pipeline optimization have used classical methods which are deterministic, while modern work has been on stochastic or evolutionary methods. Each of these methods, their advantages, and disadvantages has been discussed in the following sections.

2.2.1 Classical Methods:

These methods include the following techniques:

- (a) Dynamic Programming.
- (b) Generalized Reduced Gradient.
- (c) Heuristic Methods.
- (d) Mixed Integer Linear Programming.
- (e) Mixed Integer Non Linear Programming.

2.2.2 Stochastic Methods:

- (a) Genetic Algorithm.
- (b) Simulated Annealing
- (c) Differential Evolution.
- (d) Particle Swarm Optimization
- (e) Ant Colony Optimization

Brief discussion of each of the methods has been discussed below:

2.2.1 Classical Methods

These include methods such as dynamic programming, gradient search and heuristic methods.

2.2.1a Methods based on Dynamic Programming

Dynamic programming has been one of the oldest and most widely used methods for optimizing gas pipeline operations (Jamshidifar et.al., 1981; Grelli, 1985; Osiadacz, 1994; Ríos- Mercado et.al. 2002). Dynamic programming has the advantage that global optimum is guaranteed and nonlinearity of the problem can be handled easily. There are two major disadvantages of dynamic programming. The first, major disadvantage is that it is applicable to only non-cyclic networks. The second disadvantage is that the computation time increases exponentially when the dimensions of the problem increases. For example, it was utilized for minimizing fuel consumption in compressors which had the drawback of its applicability to only simple networks and solution obtained from this technique were local optimal solutions only (Jamshidifar et.al., 1981). The method was also tried for solving cyclic networks, but failed for the non sparse network (Grelli, 1985).

2.2.1b Method Based on Gradient Search

The advantage of Gradient search method, is that these methods can handle the dimensionality issue very well, and thus, can be applied to cyclic structures (Rozer, 2003; Adeyanju et al., 2004; Bakhouya, 2008; Tabkhi, 2007). But since this method is based on gradient search, there is no guarantee of finding a global optimal solution. This is especially an issue when the network problem contains discrete decision variables. The method was utilized for minimizing fuel consumption and cost which did not yield a global optimum (Adeyanju et al., 2004). A further attempt was made for minimizing the fuel consumption by following a two step approach. In the first step an initial solution was found by employing relaxation on pressure constraint and

eliminating the compressors in the pipeline and then further utilizing the initial solution obtained in the first step and then taking into account both pressure constraint and compressors to find the final solution. CONOPT solver of General Algebraic Modeling System software was used to obtain the solution that yielded only local optima (Bakhouya & Wolf, 2008). The same solver was again used for minimizing the fuel consumption (Tabkhi, 2007) that yielded local optima only.

2.2.1c Method based on Heuristic Approaches

These methods include the heuristic of ordering the compressors in decreasing priority and to start as many compressors as are required to satisfy the station throughput. The drawback of these methods is that these methods require an iterative search of different combinations that makes them a CPU intensive technique (Ferber, 1999; Conrado, 2005).

2.2.1d Mixed Integer Linear Programming Methods

Mixed Integer Linear Programming methods are also there in which assumptions are made to convert a nonlinear function to a linear one. However, this method leads to a suboptimal solution even for a single compressor (Uraikul, 2004).

2.2.1e. Mixed Integer Non Linear Programming Methods

These methods utilize branch and bound techniques to find the optimal solution. The drawback of these methods is that the methods require an initial solution to the problem and then only further progress of finding a solution can be made. This makes it a CPU intensive technique (Diana, 2002).

Both Mixed integer linear programming and mixed integer nonlinear programming

use method of slopes for calculation. Hence these methods require the objective function to be smooth and convex, that cannot be always guaranteed. Real life problems are neither always smooth nor convex.

The drawbacks of using Classical Methods

Above section 2.2.1 discussed the major classical techniques that have been used for optimizing gas pipeline operations. However, these methods have the following disadvantages:

- i. Convergence to an optimal solution depends on the initial chosen solution.
- ii. The algorithm gets easily trapped in local optima.
- iii. Cannot be used on parallel computers.
- iv. Cannot efficiently handle problems having discrete variables.

To overcome the above drawback of classical methods, stochastic methods are now becoming popular.

2.2.2 Stochastic Methods

Stochastic methods are probabilistic methods used for finding optimal solutions. Evolutionary Algorithm, are stochastic search methods that either mimic, the natural biological evolution or the social behavior, of biological species. Genetic Algorithm, Differential Evolution, Particle Swarm Optimization, Ant Colony Optimization, Simulated Annealing are some of the major stochastic methods that have been used in the recent years for optimizing pipeline operations (Elbeltagi., E. 2005). A brief description of these methods is given:

2.2.2a Genetic Algorithm (GA) is a [search heuristic](#) that mimics the process

of [natural selection](#) (Goldberg, D.E. 1983). The technique belongs to the larger class of [evolutionary algorithms](#), which generate solutions to optimization problems using techniques inspired by natural evolution, such as [inheritance](#), [mutation](#), [selection](#), and [crossover](#).

2.2.2b Differential Evolution (DE) belongs to the class of evolutionary algorithm which uses biologically-inspired operations of crossover, mutation, and selection on a population in order to minimize an objective function over the course of successive generations (Price K., 2005). As with other evolutionary algorithms, Differential Evolution solves optimization problems by evolving a population of candidate solutions using alteration and selection operators.

2.2.2c Particle swarm optimization (PSO) is a population based stochastic optimization technique that shares many similarities with evolutionary computation technique such as Genetic Algorithms (Kennedy, J. 2001). The system is initialized with a population of random solutions and searches for optima by updating generations. However, unlike Genetic Algorithm, PSO has no evolutionary operators such as crossover and mutation. In PSO, the potential solutions, called particles, fly through the problem space by following the current optimum particles.

2.2.2d Simulated Annealing (SA) is a generic probabilistic meta-algorithm that is used to find approximate solution to global optimization problems (Kirkpatrick, S. 1983). It is inspired by annealing process in metallurgy which is a technique of controlled cooling of material to reduce defects. The simulated annealing algorithm starts with a random solution. Each of the iteration performed forms a random nearby

solution. If this solution is a better solution than the previous solution, it replaces the current solution. If it is a worse, then it may be chosen to replace the current solution with a probability that depends on the temperature parameter. As the algorithm progresses, the temperature parameter decreases, giving worse solutions a lesser chance of replacing the current good solution. It was used for finding optimal configuration (Somani *et al*, 1998) and finding optimal layout (Rodriguez *et al*, 2013).

2.2.2e Ant Colony Optimization is a newer evolutionary method that is slowly gaining importance in the field of optimization. This technique mimics the social behavior of ants during the search of shortest route between the nest and the food source. The application of ant colony has been used for optimizing pipe diameter (Mohajeri, 2012) and minimizing fuel cost in compressors (Chebouba, 2009).

Advantages of Stochastic Methods

These methods can be applied efficiently at the places where heuristic solutions are not available or have resulted to unsatisfactory results. Following are some of the major advantages of using Stochastic Methods:

- i. Conceptually Simple
- ii. Potential to hybridize with other methods.
- iii. Can run on Parallel Computers
- iv. Robust to dynamic changes.
- v. Have the Capability to solve problem that have no initial solution.

2.3 Application of Various Optimization Methods to Optimization of Gas Pipeline Networks

Detail on the methodology adopted by different authors in pipeline optimization is presented here.

Jamshidifar *et al.*, (1981) developed GTNOpS software using Unified Modeling Language and C++ technology. The objective was to minimize fuel consumption in compressors. *Dynamic programming* was used as mathematical approach and *genetic algorithm* was used as heuristic method. Simulation results showed that the software worked well on the pipeline network.

Grelli *et al.*, (1985) developed a computer program for minimizing fuel consumption that utilized *dynamic programming technique*. The program was successfully implemented by Pacific Gas Transmission Company to help in operating its interstate gas transmission pipeline.

Adewumi *et al.*, (1993) developed *step-forward algorithm* for designing gas pipeline network. The method was very simple as small-size pipeline network could be easily analyzed even with a programmable calculator.

Osiadacz, (1994) applied hierarchical system theory for *dynamic optimization* of high-pressure gas pipeline networks. The objective was to minimize fuel cost. Promising results were obtained by using this technique.

Carter *et al.*, (1996) implemented *branch-and-bound algorithm* to pipeline optimization problems and found that using this technique speedups of orders of

higher magnitude was obtained as compared to other techniques used at his time.

Mohitpur et al., (1996) utilized *dynamic simulation* technique for designing and optimizing steady state pipeline transmission systems.

Carter et al., (1998) directly applied *Dynamic programming technique* to complex branched and looped pipeline systems. Results revealed that using the technique not only assured the accuracy, but also resulted in 10 times faster evaluations as compared to hybrid methods. The model was capable of determining compressor speed, power requirement, engine fuel consumption, and head for each compressor with respect to time.

Sung et al., (1998) presented *a hybrid network model (HY-PIPENET)* that used minimum cost spanning tree for analysis. Parametric studies were performed to understand the role of each individual parameter such as the source pressure, flow rate and pipeline diameter on the optimized network.

Somani, (1998) proposed *simulated annealing* technique to find the optimum configuration and power settings for multiple compressors. The method was implemented on ‘Texas Eastern Gas Transmission Corporation’ that compares the results of Simulated Annealing against the more ubiquitous mixed integer non-linear and heuristic techniques.

Cameron, (1999) presented an Excel-based model for steady state and transient state simulation. The model comprised a user interface written in Microsoft Excel’s ‘Visual Basic for Applications’, and dynamic linked library written in C++. The robustness of general applications, however, was not readily apparent.

Majid *et al.*, (2000) developed algorithms that utilized the concepts of ‘Newton loop-node method’ and ‘Hardy Cross method’. A computer program developed was used for selecting pipe sizes, calculating pressures and flow in the gas distribution network.

Summing *et al.*, (2000) considered the problem of minimizing fuel cost incurred in the compressor station under steady-state conditions. Two model relaxations one in the compressor domain and other in the fuel cost function domain was proposed and the lower bounding scheme was derived. Results show that lower bounding scheme when used for small gas network problems yielded a relative optimality gap of around 15-20% but failed for large complex network systems.

Ferber *et al.*, (2000) detailed the techniques that can be used to determine optimal operating regions, schedule changes to move the pipeline from one optimal state to another, and automatically implement these changes using model predictive controllers. The optimal operating conditions that meet all constraints and minimize fuel consumption for the pipeline was determined by deciding the compressor units that need to be run at each compressor station and the best suction pressure set point at each compressor station.

Montoya *et al.*, (2000) presented modified genetic algorithm to optimize gas transmission network operating under steady-state conditions. Results found show that the technique was capable of finding optimum pipeline diameter for a minimum investment cost.

Rios-Mercado et al., (2002) presented reduction technique for minimizing fuel consumption in natural gas transmission network. The main contribution of his work was proposing a method that successfully reduced the problem dimension without any interference in the original network. Decision variables chosen were the mass flow rate through each pipe arc, and the gas pressure at each pipeline node.

Diana et al., (2002) presented *mixed-integer nonlinear programming model* for minimizing fuel consumption in natural gas pipeline network. Computational results on different network topology and different type of compressor units show the effectiveness of this model.

Klaus et al., (2003) developed an optimization model by focusing on partial differential equations and other nonlinear aspects together with discretization for transient optimization in large networks with Sequential Quadratic Programming methods. Computational results for a range of dynamic test problems demonstrated the viability of the approach.

Chapman et al., (2003) developed a model that comprised of nonlinear partial differential equations. These equations were solved by using a finite difference technique. It was found that using this technique, provided solution stability, even for relatively large time steps. The Newton - Raphson algorithm was further used for solving nonlinear finite difference equations of pipe flow.

Humberto et al., (2003) addressed the problem of minimizing fuel consumption in compressors using Generalized Reduced Gradient based algorithm. Promising results were obtained for many pipeline problems.

Adeyanju et al., (2004) utilized *Generalized Reduced Gradient algorithm* to determine the optimum economical conditions at which natural gas can be transported through a series of pipeline and compressor station. The model was applied to Lagos pipeline networks. Results show that depending on the required flow rate, some installed compressors need to be inactive for effective cost reduction.

Uraikul. V, et al., (2004) presented Mixed-Integer Linear Programming model to optimize compressor selection operations in natural gas pipeline network system. The objective was to minimize the operational cost and provide sufficient gas to the local customers. Mixed Integer Linear Programming model provided decision support in determining the optimal solutions for controlling the compressors. The model was further verified using the operation data supplied by a gas pipeline company in Saskatchewan, Canada.

Conrado, (2005) proposed a hybrid heuristic solution procedure for fuel cost minimization on gas transmission systems with a cyclic network topology. Non sequential Dynamic programming was applied keeping the gas flow variable, fixed and finding the optimum pressure variables. Then, further Tabu search was applied keeping pressure variables fixed and varying the mass flow as variables. Empirical evidence supported the effectiveness of the proposed procedure.

Bakhouya, (2008) addressed the problem of minimizing energy used for transporting gas, which means minimizing the power used in the compressors. The technique employed was similar to the one used by Conrado, 2005.

Bales et al., (2008) applied implicit box scheme to transient gas network optimization

problem. The objective function considered was minimizing cost of gas pipeline network. The problem was solved by combining *integer linear programming* based on piecewise linearization and classical sequential *quadratic program*. It was concluded that for real-life application, best optimal control solutions are obtained by combining both the approaches.

Andre et al. (2009) proposed a technique for solving the problem of minimizing investment costs on gas pipeline-transportation networks. The objective of the work was to first find the optimal location of pipeline segments that needs to be reinforced and second, the optimal diameter under the constraint of satisfaction of demands of consumers.

Woldeyohannes et al., (2009) developed a simulation model for determining flow and pressure variables for different configuration of Pipeline Network System. For determining pressure and flow rate variables, a technique based on the iterative Newton Raphson scheme was used and implemented using visual C++6. Evaluations of the simulation model with an existing pipeline network system show that the model determined the operational variables with less than ten iterations.

Armin et al., (2010) presented *mixed-integer nonlinear programming* for minimizing cost of gas pipeline network. In this approach, all nonlinearities were approximated by linear inequalities and spatial branching in such a way that in the end only linear program remains that can be solved efficiently.

Rodriguez et al., (2010) handled single objective of minimizing fuel consumption for fixed throughput using *deterministic optimization procedure*. Then further

multiobjective problem of minimizing fuel consumption and maximizing throughput was solved and compared using *genetic algorithm coupled with a Newton-Raphson procedure* and the *scalarization method of ϵ -constraints*. The Pareto front deduced from the bio-objective optimization was used for identifying the minimum and maximum network capacity in terms of CO₂ emissions and mass flow delivery or for a given mass flow delivery, for determining the minimal CO₂ emissions from the compressor stations.

Bonnans *et al.*, (2011) used Global optimization technique that was based on *interval analysis* and *constraint propagation for minimizing energy consumption in compressors*. The technique was used to solve the classical problem of optimization of Belgium gas networks.

Changjun Li, (2011) employed Adaptive genetic algorithm for maximizing the operation benefit that was obtained by taking the difference of sales and purchase cost of gas, pipeline cost and compressor running cost.

Frederic *et al.*, (2011) utilized *global optimization technique, based on interval analysis and constraint propagation* for number of pipeline optimization problems. The first being minimizing energy used in compressors for fixed topology of pipeline networks. *The second being* minimizing the sum of the cost of energy cost consumed in compressors and the net revenue due to input and output flow. The third objective was to minimize the sum of investment and operations cost. The technique succeeded in solving the problem of optimization of the Belgium gas network.

Mohajeri *et al.*, (2012) proposed Ant Colony Optimization (ACO) algorithm for

optimizing pipe diameters in a tree-structured natural gas distribution network. The proposed method was applied to the Mazandaran Gas Company, Iran and was compared with the solution obtained from exact methods.

Zhou *et al*, (2015) utilized technique that combined effectively, differential evolution algorithm with particle swarm optimization algorithm to minimize energy consumed in running Heated Oil Pipeline. The optimization results were successfully applied to a 375 km long Rizhao – Yizheng (China) heated oil pipeline.

Table 2.1: Summary of Work Done By Different Authors

S. No.	Optimization Objective	Solution Technique	Authors, Year
1	Fuel Optimization	Dynamic Programming	Grelli et al., (1985)
2	Designing of Gas Pipeline Networks	Step-Forward Algorithm	Adeyemi et al., (1993)
3	Optimization of Pipeline Transmission Systems	Dynamic Simulation	Mohitpur et al., (1996)
4	Optimization of General Branched and Looped Systems	Dynamic Programming	Carter et al., (1998)
5	Optimum Configuration	Simulated Annealing	Somani, (1998)
6	Minimizing Fuel Cost	Model Relaxations	Summing et al., (2000)
7	Optimizing Design of Gas Transmission Networks	Modified Genetic Algorithm (GA)	Montoya et al., (2000)
8	Minimizing consumption of fuel	Reduction Technique	Rios-Mercado et al., (2002)

9	Minimizing Consumption of Fuel	Mixed-Integer Non Linear Programming	Diana et al., (2002)
11	Fuel Cost Minimization	Generalized Reduced Gradient	Adeyanju et al., (2004)
12	Optimizing Compressor Selection Operation	Mixed-Integer Linear Programming (MILP)	Uraikul. V, et al., (2004)
13	Fuel Cost Minimization	Hybrid Heuristic Solution	Conrado, (2005)
14	Fuel Consumption Minimization & Fuel Cost Minimization	Dynamic programming	Tabkhi, 2007
15	Minimizing Energy	Heuristic Solution procedure	Bakhouya, (2008)
16	Minimum Cost Flow for Transient Gas Network Optimization	Mixed Integer Linear Programming.	Bales et al., (2008)
17	Minimizing Fuel Consumed	Combining Dynamic Programming Algorithm and Tabu Search.	Conrado et al., (2010)
18	Fuel Minimization	Mixed-Integer Nonlinear Programming	Armin et al., (2010)
		Genetic Algorithm	Rodriguez et al.,

19	Fuel Minimization Problem	Coupled with a Newton-Raphson procedure	(2010)
20	Optimization of the Belgium gas network	Global Optimization Techniques, Based on Interval Analysis	Bonnans et al., (2011)
21	Minimizing Total Cost	Ant Colony Optimization Technique	Mohajeri et al., (2012)
22	Finding Optimal Layout	Simulated Annealing	Rodriguez et al, (2013)
24	Minimizing Energy Consumption in a heated oil pipeline	Differential Evolution combined with Particle Swarm Optimization.	Zhou <i>et al</i> , (2015)

2.4 Analysis of the Literature

The review of literature indicates two important factors, namely, continued interest of the researchers and drawbacks of many of the works previously reported. It is clear that evolutionary methods show greater promise. Further, while several evolutionary methods such as GA have been used for pipeline network optimization, Ant Colony Optimization is a relatively unexplored methodology for Gas pipelines. It is therefore taken up for implementation and the subsequent chapters explain the work done in this regard.

It is considered important to try single objective as well as multi objective optimization. A simple single source and single delivery system also have many intricacies while implementing the Ant Colony methodology. **Chapter 3** is devoted to the two case studies, one for single and the other for multiobjective optimization using Ant Colony method. Further Algorithm developed for single and Multiobjective Ant Colony Optimization technique has also been presented. Further, the problem formulation for a multi source, multi delivery point network has also been presented.

The results obtained in both cases have been presented in **Chapter 4**, where a comparison of results obtained by earlier work is used to verify correctness of our work.

Chapter 5 gives the conclusions and perspectives for future works.

CHAPTER - 3

FORMULATION OF GAS PIPELINE NETWORK MODEL

A gas pipeline transmission network system consists of hundreds and thousands of interconnected pipe segments through which gas is first sourced from gas well heads and then sent to the exploitation areas by compressing the gas using compressors. In the previous chapter, various types of pipeline networks have been described. It is clear that every network would have nodes, branches, valves and compressor stations. The purpose of this chapter is to develop basic equations for a gas transportation model that takes into account the various elements of a gas pipeline network under steady-state conditions.

The equations have been developed under the following assumptions:

- i. The network operates under steady state conditions.
- ii. The network is balanced that is nodal material balance is satisfied.
- iii. Compressor stations include only centrifugal compressors.
- iv. The temperature remains constant along the entire length of the pipeline.
- v. Single phase gas flow is assumed.
- vi. Flat terrain is assumed.

Pipes and Compressors are the two major components of any gas pipeline network.

Here the Modelling equations of these two components are discussed. The chapter has been divided into two major sections:

3.1 Modelling of Gas Pipeline.

3.2 Modelling of Turbo-Compressors.

3.1 Modelling of Gas Pipeline.

Gas when flowing in a pipeline unlike liquids shows a compressible behavior. When Natural gas flows in pipeline, due to the changes in pressure, its properties such as density, compressibility, specific gravity vary along the length of pipeline. Analysis of the flow of compressible gas needs properties of the gas mixtures to be accurately known. A discussion of fundamental equations used for estimating properties of natural gas, and then general pipeline equations have therefore been presented first.

3.1.1 Natural gas Property Estimation

3.1.1a Average Molecular Weight

Natural Gas is a mixture of many gaseous components. The Average Molecular weight of the gas mixture having 'n' number of components is obtained from Kay's rule using equation (3.01) (Menon, S. 2005).

$$M_g = M_1 \times y_1 + M_2 \times y_2 + M_3 \times y_3 \dots \dots M_n \times y_n \quad (3.01)$$

3.1.1b Specific Gravity

The specific gravity of a gas is a measure of 'how heavy the gas is' as compared to air at a particular temperature. Sometimes it is also referred to as *relative density*. Specific gravity as shown in equation (3.02) is the ratio of the gas density to the density of air (Menon, S. 2005).

$$G = \frac{\rho_g}{\rho_{air}} \quad (3.02)$$

If, the average molecular weight of natural gas is known, then the specific gravity of the gas is obtained from the equation (3.03) (Menon, S. 2005, Mohring et al., 2004).

$$G = \frac{M_g}{M_{air}} = \frac{M_g}{28.9625} \quad (3.03)$$

When molecular weight and gas gravity of individual components in natural gas mixture is known, specific gravity of the gas mixture can be obtained by using the weighted average method. For a gas mixture containing ‘n’ number of components, gas gravity is obtained from the equation (3.04) (Mohring et al., 2004).

$$G = \frac{\sum_{i=1}^n G_i \times M_i}{28.9625} \quad (3.04)$$

Since natural gas consists of a mixture of several gases (methane, ethane, etc.), the average molecular weight M_g used in equation (3.03) is also referred to as the apparent molecular weight of the gas mixture.

3.1.1c Critical Temperature and Critical Pressure

Critical temperature of pure gas is defined as the temperature above which a particular gas cannot be compressed to form liquid, regardless of the pressure.

Critical pressure is defined as the minimum pressure that is required at critical temperature to compress the gas into liquid. At the pressure above critical pressure, liquid and gas cannot coexist, regardless of the temperature. In a similar way as average molecular weight is obtained, from the given mole fraction of the gas components, Kay’s rule is used to calculate the average pseudo-critical properties of

the gas mixture. When the gas consists of a mixture of different components, the critical temperature and critical pressure are referred to as pseudo critical temperature and pseudo-critical pressure, respectively. If the composition of the gas mixture is known, then Equation (3.05) and Equation (3.06) are used to calculate the pseudo critical temperature and pseudo-critical pressure of the natural gas containing ‘n’ components. (Menon,. S. 2005, Mohring et al., 2004)

$$T_C = \sum_{i=1}^n T_{ci} \times y_i \quad (3.05)$$

$$P_C = \sum_{i=1}^n P_{ci} \times y_i \quad (3.06)$$

3.1.1d Heating Value (H_m)

It is the amount of heat released per unit amount of fuel consumed in complete combustion. Two types of heating values are there: Higher Heating Value and Lower Heating Value. When hydrocarbons are burnt in the presence of air, carbon dioxide and water are released in the combustion product. When liquid water is the combustion product, the heating value, is called as the higher (or gross) heating value. When water vapor is the combustion product, it is called as the lower (or net) heating value. Since combustion products are always above the boiling point of water, Lower Heating Value is a better indication of fuel’s useful heat. It is calculated based on the heating values of individual component gases and their mole fraction in the gas mixture using equation (3.07). (Menon,. S. 2005, Mohring et al., 2004)

$$H_m = (H_1 \times y_1 \times M_1) + (H_2 \times y_2 \times M_2) + (H_3 \times y_3 \times M_3) + \dots H_n \times y_n \times M_n$$

(3.07)

3.1.1e Average Density of Natural Gas

Following modified ideal gas equation (3.08) also called as the equation of state is used to calculate density of natural gases. (Menon, S. 2005, Mohring et al., 2004)

$$\rho_{av} = \frac{P_{av} \times M_{av}}{Z_{av} \times R \times T}$$

(3.08)

3.1.1f Compressibility factor of Natural Gas

The modifying factor included in the modified ideal gas Equation 3.08 is called compressibility factor Z . This is also called the gas deviation factor. It is defined as the ratio of the gas volume, at a given temperature and pressure to the volume of the gas that it would occupy if it was considered as an ideal gas at the same temperature and pressure. Z is a dimensionless number that varies with temperature, pressure, and composition of the gas. Traditionally, the compressibility factor is calculated using equation of state. For natural gas, it is estimated from the empirical relationship proposed in the literature equation (3.09) (Mohring et al., 2004).

$$z = 1 + \left(0.257 - 0.533 \times \frac{T_C}{T} \right) \times \frac{P_{av}}{P_C} \quad (3.09)$$

Additionally, one more very popular equation for calculating compressibility factor is given in equation (3.10). This method of obtaining compressibility factor is referred to as California Natural Gas Association (CNGA) Method (Menon, S. 2005).

$$z = \frac{1}{\left[1 + \frac{(P_{av} \times 344,400 \times 10^{1.785G})}{T_f^{3.825}} \right]} \quad (3.10)$$

The above equation is valid when the average gas pressure, is more than 100 psig. For pressures less than 100 psig, compressibility factor is approximately equal to 1.00.

3.1.1g Viscosity of Natural Gas

Natural gas is a mixture of various component gases such as methane, ethane, propane, etc. Equation (3.11) is used to calculate the viscosity of natural gas from the viscosities of individual component gases (Mohring et al., 2004).

$$\mu = \frac{\mu_1 y_1 \sqrt{M_1} + \mu_2 y_2 \sqrt{M_2} + \mu_3 y_3 \sqrt{M_3} + \dots + \mu_n y_n \sqrt{M_n}}{y_1 \sqrt{M_1} + y_2 \sqrt{M_2} + y_3 \sqrt{M_3} + \dots + y_n \sqrt{M_n}} \quad (3.11)$$

3.1.1h Mass of Natural Gas flowing in the pipeline

The mass of gas flowing in a pipeline in kg/sec is obtained from the equation (3.12).

$$m_i = \rho_i \times Q_i \quad (3.12)$$

With the preceding discussion on estimation of properties of Natural Gas it should now be possible to look at the behavior of Natural Gas while flowing in pipelines. This is done in the following section.

3.1.2 General Pipeline Equations

When Natural gas flows in pipeline, due to the changes in pressure, its properties such as density, compressibility, specific gravity varies along the length of pipeline. To account for these changes, here the momentum equation in one dimensional flow is considered. The application is a good approximation for any type of gas pipeline

network. In the equation, the cross sectional area of each pipeline segment is constant (but different from other pipeline segments), and curvature of the pipe centerline is very large as compared to the cross-sectional dimensions. The basic equations used for describing the gas flow in pipes are derived from momentum balance equations (equation of motion), equation of continuity, and energy balance equation. In practice, however, the form of the mathematical models varies with the assumptions made corresponding to the conditions of the pipeline operation (Osiadacz, 1987). Simplified, models are obtained by neglecting some of the terms in the basic model (for example, if gas flow is steady, then the terms containing time must be neglected, also if pipeline is in horizontal terrain then the term α will be zero). Following section reviews the fundamental pipeline equations that are used to define the pipeline Modelling system.

3.1.2a Conservation of Mass: Continuity Equation

When gas flows in pipeline, the total mass of gas remains conserved. Equation (3.13) is the equation of continuity that is based on conservation of mass in three coordinate systems.

$$\frac{\partial(\rho u)}{\partial x} + \frac{\partial(\rho v)}{\partial y} + \frac{\partial(\rho w)}{\partial z} + \frac{\partial\rho}{\partial t} = 0$$

(3.13)

Considering the flow in only x direction, following equation (3.14) holds good for mass conservation:

$$\frac{\partial(\rho u)}{\partial x} + \frac{\partial\rho}{\partial t} = 0$$

(3.14)

For steady state conditions,

$$\frac{\partial \rho}{\partial t} = 0$$

Hence

$$\frac{\partial(\rho u)}{\partial x} = 0$$

Or $\rho u = \text{Constant}$

Or $A \rho u = \text{Constant}$

Or $\dot{m} = \text{Constant}$ (3.15)

The above equation (3.15) is used to apply mass conservation on each node of the pipeline network.

3.1.2b Equation of Motion: Momentum Balance

Pressure drop in a gas pipeline is an essential parameter that is required to determine the power consumed in compressing the gas. The equations for pressure drop in pipeline segment are derived from the differential momentum balance applied to a control volume. The present section discusses the application of one dimensional flow model that is used to calculate pressure drop in each pipeline segment. The model is based on energy conservation principle which states that ‘In a flowing fluid the total energy of the fluid remains constant’. Various components of the fluid energy may transform from one form to another, but no energy is lost as the fluid flows in a pipeline. Starting with the energy balance on a control volume and taking

into account various parameters, an equation has been developed for calculating pressure drop per unit length in gas pipelines. This basic equation refers to the Fundamental Flow Equation, which is also known as the General Flow equation. The governing equation to calculate the pressure drop in each pipe segment is obtained from the equation (3.16).

$$\frac{\partial P}{\partial x} + \frac{f \rho v^2}{2D} \pm g \rho \sin \alpha + \frac{\partial(\rho v^2)}{\partial x} + \frac{\partial(\rho v)}{\partial t} = 0 \quad (3.16)$$

In the above equation, P is the pressure in (Pa); and α is the angle between the horizontal and the pipe centerline direction, x . The sign of the gravity term in the Equation (3.16) is positive if the gas flows upward and is negative when the gas flows downward. The Darcy friction factor, f , is a dimensionless value that is a function of the Reynolds number, Re , and relative roughness of the pipeline.

3.1.2c Pressure drop Equation

As evident from the above equation (3.16), for compressible flow as pressure changes along the pipeline line, density also changes. A rigorous calculation of pressure loss for long cross country pipeline involves, dividing the pipeline into small segments, performing the calculation for each segment and then integrating over the entire length. The relationship between pressure and flow exhibits a high degree of nonlinearity. Equation (3.16) can be further simplified to yield the following equation (3.17) for pressure drop calculations. The detailed simplification is shown in Appendix A.

$$(P_2^2 - P_1^2) - 32 \left(\frac{\dot{m}^2 zRT}{\pi^2 D^4 M} \right) \ln \left(\frac{P_2}{P_1} \right) + \left(\frac{16 f zRT}{\pi^2 D^5 M} \right) \dot{m}^2 L = 0 \quad (3.17)$$

3.1.2d Reynolds Number

Pressure drop in pipe segment that is obtained from Equation (3.17) requires the calculation of friction factor f which is a function of ‘Reynolds Number’ the ratio of inertial forces to viscous forces. It is obtained from equation (3.18).

$$Re = \frac{\rho u d}{\mu} \quad (3.18)$$

However, in gas pipeline, equation (3.19) is used to calculate Reynolds Number. (Menon, S. 2005).

$$Re = 0.5134 \left(\frac{P_b}{T_b} \right) \left(\frac{GQ}{\mu D} \right)$$

(3.19)

Depending on Reynolds number, three regimes have been defined:

Laminar flow, for $Re \leq 2000$

Turbulent flow, $Re > 4000$

Transition flow, $Re > 2000$ and $Re \leq 4000$

Most natural gas pipelines operate in the turbulent flow region. Turbulent flow is further divided into following three regimes:

1. Turbulent flow in smooth pipes
2. Turbulent flow in fully rough pipes
3. Transition flow between smooth pipes and rough pipes.

Method for calculating friction factor in these three regimes is discussed next.

3.1.2e Friction Factor

The term *friction factor* is a dimensionless parameter that depends on the Reynolds number of fluid flow. In the literature, two different friction factors have been mentioned, Darcy friction and fanning friction factor (Cengel, Y. 2006). Darcy friction factor is more commonly used as compared to Fanning friction factor.

Equation (3.20) correlates Fanning and Darcy friction factor:

$$f_f = \frac{f}{4} \quad (3.20)$$

In the above equation f_f is the fanning friction factor and f is the Darcy friction factor. For laminar flow, the friction factor is inversely proportional to the Reynolds number, as indicated in equation (3.21) (Cengel, Y. 2006).

$$f = \frac{64}{\text{Re}} \quad (3.21)$$

The value of friction factor can also be obtained from Moody's plot (Elger, F. 2013). Moody diagram is a graphical plot of the variation of the friction factor with the Reynolds number for various values of relative pipe roughness.

Relative roughness is obtained from equation (3.22).

$$\text{Relative Roughness} = \frac{e_i}{D_i} \quad (3.22)$$

In pipelines, high velocity of the gas is desirable, hence the flow remains turbulent. Friction factor for turbulent flow is obtained from Colebrook-White equation which is further discussed.

3.1.2f Colebrook –White Equation

Colebrook-White equation correlates friction factor, Reynolds number, pipe roughness, and inside diameter of pipe. Equation (3.23) is a Colebrook White equation that is used to calculate the friction factor in gas pipelines in turbulent flow (Elger, F. 2013).

$$\frac{1}{\sqrt{f}} = -2 \log_{10} \left(\frac{e}{3.7D} + \frac{2.51}{\text{Re} \sqrt{f}} \right) \quad (3.23)$$

It can be seen from the above Colebrook Equation that for turbulent flow in smooth pipes, the first term within bracket is negligible as compared to the second term. This is because the pipe roughness e is very small. Therefore, for smooth pipe flow, the friction factor equation (3.23) reduces to equation (3.24).

$$\frac{1}{\sqrt{f}} = -2 \log_{10} \left(\frac{2.51}{\text{Re} \sqrt{f}} \right) \quad (3.24)$$

Similarly, for turbulent flow in fully rough pipes, Re is a large number, and hence f depends mostly on the roughness e of the pipe. Therefore, friction factor equation (3.23) reduces to equation (3.25).

$$\frac{1}{\sqrt{f}} = -2 \log_{10} \left(\frac{e}{3.7D} \right) \quad (3.25)$$

3.1.2g Average Pressure Calculation

In a gas pipeline, pressure varies along the length of the pipeline. Following Equation (3.26) is used for calculating average pressure between two points in a gas pipeline segment (Menon, S. 2005).

$$P_{av} = \left(\frac{2}{3} \right) \times \left[P_i + P_j - \frac{P_i \times P_j}{P_i + P_j} \right] \quad (3.26)$$

The derivation of the above equation has been given in Appendix B.

Another form of the average pressure in a pipe segment is given in equation (3.27).

$$P_{av} = \left(\frac{2}{3}\right) \times \left[\frac{P_i^3 - P_j^3}{P_i^2 - P_j^2} \right] \quad (3.27)$$

3.1.2h Maximum Allowable Operating Pressure (MAOP)

Gas flowing in pipeline causes the pipe wall to be stressed, and if allowed to reach the yield strength of the pipe material, it could cause permanent deformation of the pipe and ultimate failure. In addition to the internal pressure due to gas flowing through the pipe, the pipe might also be subjected to external pressure, which can result from the weight of the soil above the pipe in a buried pipeline and also by the probable loads transmitted from vehicular traffic. The pressure transmitted to the pipe due to vehicles above ground will diminish with the depth of the pipe below the ground surface. In most cases involving buried pipelines the effect of the internal pressure is more than that of external loads. Therefore, the necessary minimum wall thickness is dictated by the internal pressure in gas pipelines. The pressure at all points of the pipeline should be less than the Maximum Allowable Operating Pressure (MAOP) which is a design parameter in the pipeline engineering. Barlow's formula as given in equation (3.28) is used in design codes for petroleum and natural gas transportation systems to calculate the allowable internal pressure in a pipeline (Menon, S. 2005).

$$P_{MAOP,i} = \frac{2 \times t_i \times S \times E \times F \times T}{D_i}$$

(3.28)

The Maximum allowable operating pressure equation requires the calculation of following terms:

- ✓ Specified minimum yield stress S.
- ✓ Efficiency of pipeline E.
- ✓ Design factor F.
- ✓ Temperature de-ration factor T'.

These terms have been discussed next:

Specified Minimum Yield Stress (SMYS) is a common term used in the oil and gas industry for steel pipe used under the jurisdiction of the United States Department of Transportation. It is an indication of the minimum stress, a pipe may experience that causes plastic (permanent) deformation. Steel pipes used in gas pipeline systems generally conform to API 5L and 5LX specifications. These are manufactured in grades ranging from X42 to X90 with SMYS. The values of SMYS for different pipe grade material can be obtained from Menon, S. 2005.

Joint Efficiency

Pipelines are generally used bends for changing the direction of gas flow. These bends are welded in pipeline, giving joints. Joint efficiency 'E' in a pipeline represents a generic level of confidence in the overall strength of the weld seam considering the methods that were used to produce the seam and the thoroughness of the inspection in seam quality and testing of strength. Values of Joint Efficiency can be obtained from Menon, S. 2005.

Design Factor

Design factor F is decided on the basis of class location which in turn depends on the population density in the vicinity of the pipeline (Menon, S. 2005).

Class location has been discussed first:

Class Location

The following definitions of class 1 through class 4 are taken from DOT 49 CFR, Part 192 (Department of Transportation—DOT Code of Federal Regulation 49CFR Part 192, Oct. 2000). The class location unit (CLU) is defined as the number of buildings an area that extends 220 yards (201.08 m) on either side of the center line of a 1-mile (1.6km) section of pipe.

Class 1

Offshore gas pipelines lie in Class 1 locations. For onshore pipelines, any unit that has 10 or fewer buildings that are intended for human occupancy is termed as Class 1 location.

Class 2

Any class location unit that has more than 10 but fewer than 46 buildings that are intended for human occupancy is termed as Class 2 locations.

Class 3

This is a class location unit that has 46 or more buildings that are intended for human occupancy. Class location 3 also represents an area where the pipeline is within 100 yards of a building or a playground, recreation area, outdoor theatre, or other place of public assembly that is occupied by 20 or more people at least 5 days a week for 10 weeks in any 12-month. Here the days and weeks need not be consecutive.

Class 4

This is a location unit where buildings with four or more stories above ground exist.

Now, after identifying the number of buildings nearby pipeline areas and hence the class location, design factor is identified accordingly (Menon, S. 2005).

Design factor F, for class location 1 = 0.72

Design factor F, for class location 2 = 0.6

Design factor F, for class location 3 = 0.5

Design factor F, for class location 4 = 0.4

Temperature De-ration Factors T'

It is decided on the following basis (Menon, S. 2005):

For Temperature $< 121^{\circ}C$, $T' = 1$

For Temperature $121^{\circ}C < 177^{\circ}C$, $T' = 0.962$

For Temperature $177^{\circ}C < 204^{\circ}C$, $T' = 0.9$

For Temperature $204^{\circ}C < 232^{\circ}C$, $T' = 0.867$

3.1.2 i Velocity of gas in pipeline

Since gases are compressible, the compressibility of gas and hence velocity of gas in each pipeline segment is different. The velocity of the gas flow in a pipeline represents the speed at which the gas molecules move from one point in a pipeline to another point in the pipeline. Gas velocity is highest at the downstream end of the pipeline, where the pressure is lost. Correspondingly, the gas velocity will be lower at the upstream end, where the pressure is highest. Equation (3.29) is used for calculating velocity in pipeline segments.

$$v_i = 14.7359 \times \left(\frac{Q_i \times 24 \times 3600}{(D_o \times 10^3 - 2 \times t_i \times 10^3)^2} \right) \times \left(\frac{P_b}{T_b} \right) \times \left(\frac{z_i \times T}{P_{ij} \times 10^2} \right)$$

(3.29)

Derivation of equation (3.29) is given in Appendix C.

Most of the Companies like "Shell" recommend that gas velocities in the transportation of natural gas through long-distance pipelines should be in the range of 5-10 m/s for continuous operation and a maximum up to 20 m/s for intermittent operation.

3.1.2 j Critical velocity

Gas velocity and its flow rate in the pipeline are interconnected. As the velocity of gas increases, flow rate of gas also increases. The increase of velocity is due to increase in pressure drop of gas. However, there is a limit to this velocity. Sonic velocity or critical velocity of gas in a pipeline is the maximum velocity, which a compressible fluid can reach in a pipeline. For trouble free operation of the gas pipeline, velocity of gas must be always lower than the sonic or critical velocity.

Equation (3.30) is used to calculate velocity of gas in the pipeline.

$$c_i = \sqrt{\frac{kz_i RT}{M}} \quad (3.30)$$

For a system of 'n' components the average isentropic exponent 'k' is obtained from the equation (3.31) (Menon, S. 2005).

$$k = \frac{(C_{p1} \times y_1 + C_{p2} \times y_2 + C_{p3} \times y_3 + \dots C_{pn} \times y_n)}{(C_{p1} \times y_1 + C_{p2} \times y_2 + C_{p3} \times y_3 + \dots C_{pn} \times y_n) - R} \quad (3.31)$$

Velocity of gas in the pipeline is generally kept half of the sonic velocity as given in equation (3.32) (Menon, S. 2005).

$$v < \frac{c}{2}$$

(3.32)

3.1.2 k Erosional velocity

High velocity of gas in pipeline results in increased vibration level and noise. Exposure of pipeline to high gas velocity for long duration results in erosion and corrosion to interior walls of pipeline. Gas velocity in the pipeline must be such so as the cavity formation as well as impingement attack is minimal on gas pipeline walls. Consideration should be always given in such a way that the flow velocity remains within a range where corrosion is minimized. The lower limit of the flow velocity range should be such that the impurities keep suspended in the pipeline, thereby minimizing accumulation of corrosion matter within the pipeline. Erosional velocity always lie below the sonic or critical velocity and is calculated from the following equation (3.33) or (3.34).

$$v_{e_i} = 122 \sqrt{\frac{z_i \times R \times T}{P_{av} \times M}}$$

(3.33)

Or,

$$v_{e_i} = 122 \sqrt{\frac{z_i \times R \times T}{P_{av} \times 29G}}$$

(3.34)

Operating velocity is always kept below 50 % of the erosional velocity.

3.2 Modelling of Turbo Compressors

Turbo compressors are used for increasing the pressure of gas, which is achieved by compression of the gas. The energy required for compression is achieved by burning some of the natural gas moving in pipeline. Economic success of entire compression operation depends significantly on the operation of compressors which further depends on accurate calculation of isentropic head, isentropic efficiency, fuel consumption, surge and stone wall limit. Following section discusses these important terms and equations which are used for Modelling the turbo compressors.

3.2.1 Isentropic Head

“Head” is the term used to describe the amount of energy that is added to a unit of mass of gas that is being compressed. It is the enthalpy rise from suction end to discharge end. Equation (3.35) is used for calculating isentropic head across compressors (Smith and Van Ness, 1998).

$$h_{ij} = \left(\frac{z_i \times R \times T}{M} \right) \times \left(\frac{k}{k-1} \right) \times \left[\left(\frac{P_j}{P_i} \right)^{\frac{k-1}{k}} - 1 \right]$$

(3.35)

3.2.2 Efficiency of Compressors

Three types of efficiency are described for compressors. These are:

- i.* Mechanical Efficiency (η_m)
- ii.* Isentropic Efficiency (η_{is})
- iii.* Driver Efficiency (η_d).

3.2.2a Mechanical efficiency (η_m) measures the effectiveness of a machine in transforming the energy and power that is input to the device into an output force and movement.

3.2.2b Isentropic efficiency (η_{is}) of a compressor is defined as the work required to compress the gas in an isentropic process divided by the actual work used to compress the gas. In isentropic process temperature remains constant in compression. But in actual practice, there is always rise in temperature that affects the efficiency of the compressor and hence it should be taken into account. Equation (3.36) is used to calculate the isentropic efficiency of the compressor in a polytropic process. The detailed derivation of isentropic efficiency is given in Appendix D.

$$\eta_c = \frac{\left(\frac{P_2}{P_1}\right)^{\left(\frac{k-1}{k}\right)} - 1}{\left(\frac{P_2}{P_1}\right)^{\left(\frac{n_p-1}{n_p}\right)} - 1} \quad (3.36)$$

3.2.2 c Driver Efficiency (η_d) of turbine is defined as the efficiency of a compressor in converting the input energy to the turbine to the energy that will be actually utilized in running the compressor. These three efficiencies are used for calculating fuel consumption in compressors.

Isentropic head and isentropic efficiency can also be calculated using Fan law which is simplified but still a very accurate representation of the head and efficiency (Odom, M.F., 2009). Equation (3.37) and (3.38) are used for calculating isentropic head and isentropic efficiency.

$$\frac{h}{\omega^2} = b_1 + b_2 \left(\frac{Q}{\omega} \right) + b_3 \left(\frac{Q}{\omega} \right)^3 \quad (3.37)$$

$$\eta = b_4 + b_5 \left(\frac{Q}{\omega} \right) + b_6 \left(\frac{Q}{\omega} \right)^2 \quad (3.38)$$

3.2.3 Fuel Consumption in Compressors

When gas is transported through pipelines, pressure energy is lost due to friction and elevation in pipelines. This necessitates the use of recompression of gas using compressors. Figure 3.1 shows a schematic figure of turbo compressor used in pipelines.

Fuel consumed in compressors in compressing the gas is a function of isentropic head; the mass flow rate at the outlet of the compressor, and various efficiencies. Equation (3.39) is used for calculating fuel consumption in turbine run compressors.

$$m_f = \left(\frac{m_j \times h_{ij}}{H_m} \right) \times \left(\frac{10^2}{\eta_{is}} \times \frac{10^2}{\eta_d} \times \frac{10^2}{\eta_m} \right) \quad (3.39)$$

The detailed derivation of fuel consumed in compressors is given in Appendix E.

3.2.4 Surge and Stone wall limits in Compressors

Surge and Stone wall are the two very common phenomenons that occur in centrifugal compressors.

Surge limit defines the flow below which, for a given speed, the pressure at the discharge end of the compressor exceeds the pressure-making capability of the

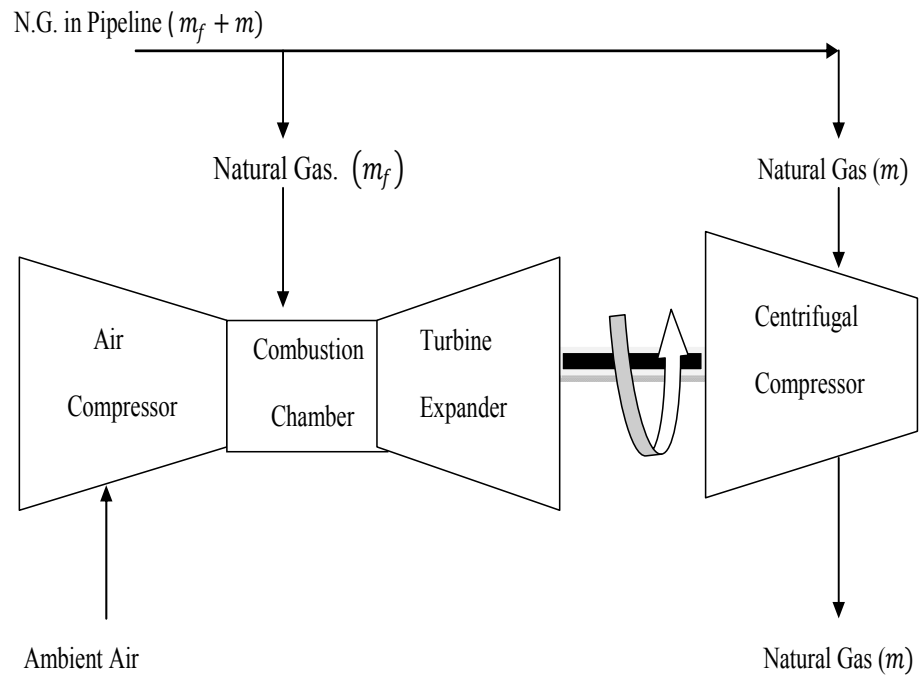

Fig. 3.1 Schematic Diagram of Turbo- Compressor used in Pipeline

Compressor, causing a momentary reversal flow. When this flow reversal occurs, the pressure of the discharge end is reduced; allowing the compressor to resume delivering flow until the discharge pressure again increases.

When operating in a surge condition, the compressor discharge temperature increases significantly and the compressor experiences erratic and severe vibration levels that cause mechanical damage, particularly to the internal seals.

For successful operation of centrifugal compressor the operating point must be at a sufficient distance from the surge line obtained from equation (3.40) and (3.41).

$$Q_s = \frac{1}{\lambda^{1/2}} \left[\left\{ \frac{z_s RT}{P_s^2 M} \left(\frac{k-1}{k} \right) h_s + \left(\frac{z_s RT}{P_s M} \right)^2 \right\}^{\frac{k}{k-1}} - \left(\frac{z_s RT}{P_s M} \right)^2 \right]^{1/2}$$

(3.40)

Derivation of equation (3.40) is given in Appendix F.

Q_{surge} is the flow rate at surge conditions obtained from equation 3.41 .

$$\frac{h_{surge}}{\omega^2} = b_1 + b_2 \left(\frac{Q_{surge}}{\omega} \right) + b_3 \left(\frac{Q_{surge}}{\omega} \right)^2 \quad (3.41)$$

In the above equation h_{surge} is the surge head at specific compressor speed (Abbaspour et al., 2005).

The distance between operating point and surge line is called surge margin.

It is calculated from equation (3.42) which has been obtained by dividing the distance of operating point from the surge line by the total flow.

$$\lambda_{surge} \leq \frac{Q_s - Q_{surge}}{Q_s} \quad (3.42)$$

A compressor can be brought out of the surge in a number of ways. The most obvious is to increase the flow. Decreasing discharge pressure and/or increasing speed are other ways to move out of a surge condition.

The stonewall limit defines the flow at which the gas velocity at one of the impellers approaches the velocity of sound. Above stonewall limit (or choke) flow, it is not possible to develop head or pressure. If the flow exceeds the stonewall limit, the only remedy is to reconfigure the compressor with impellers (and matched stationary hardware) designed for larger flow rates. Choking can be avoided in the compressor if the condition of equations (3.43) is satisfied:

$$Q_s \leq \left(\frac{\pi D^2}{4} \right) \times c \times \left(\frac{2}{k+1} \right)^{\frac{k+1}{2(k-1)}} \quad (3.43)$$

3.3 Modelling and Formulation of the Optimization Problems

Section 3.1 and 3.2 presented a general mathematical formulation used in Modelling of gas pipeline network. The present chapter discusses two gas pipeline networks with most of the reference equations already mentioned in Sections 3.1 and 3.2. Two case studies, one for single and the other for multiobjective optimization using Ant Colony method is presented. Algorithm developed for single and Multiobjective Ant Colony Optimization technique have also been presented.

3.3.1 Network 1: Network with Single Source and Single Delivery Station

3.3.1a Network Description

Figure 3.3 shows a gas pipeline network connecting a single gas source to a single delivery node. The network consists of three very long pipelines. The first one from gas supply node (N_0) to compressor station 1 inlet node (N_1), second from the compressor station 1 outlet node (N_8) to compressor station 2 inlet nodes (N_9) and the third from compressor station 2 outlet nodes (N_{16}) to the delivery node (N_{17}). The two intermediate compressor stations operate to compensate for pressure drop in pipelines. Each compressor station includes three parallel centrifugal compressors. At each station, there are six short pipe segments of very small length (as compared to the other three longer pipelines). These pipelines are linked to the entrances and outlets of the compressors.

N_0 is designated as supply node and N_{17} as the delivery node. The pressure at the supply node and delivery node is to be within $\pm 2\%$ of the specified 60 bars. The pipeline network consists of eighteen pressure variables at different nodes, fifteen mass rate variables in pipe arcs, six compressor speed variables and six fuel consumption variables in compressors. A total of forty five decision variables have been chosen. The node wise list of Pressure and Mass flow rate variables along with diameter and length of line segments is listed in Table 3.1. The variables at the compressor node are listed in Table 3.2. Parameters of various gas components present in the gas mixture are obtained from Table 3.3.

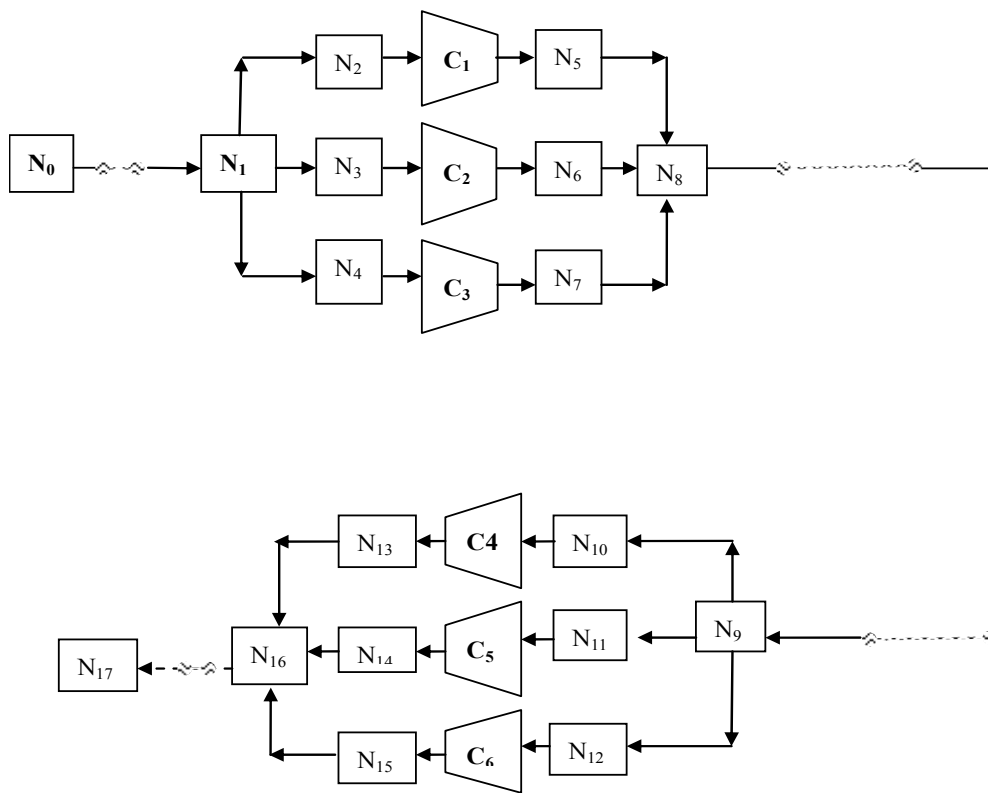

Fig. 3.2 Single Source Single Delivery Gas Pipeline Network System

Table 3.1 Notation in Pipe Arcs

S. No.	Node	Pressure	Pipe Arc	Diameter of Pipe Arc	Length of Pipe Arc	Compressibility	Mass Rate	Velocity of Gas in Pipeline
1	N ₀	P ₀	N ₀ -N ₁	D ₁ = 0.787	L ₁ = 10 ⁵	z ₁	m ₁	v ₁
2	N ₁	P ₁	N ₁ -N ₂	D ₂ = 0.330	L ₂ = 200	z ₂	m ₂	v ₂
3	N ₂	P ₂	N ₁ -N ₃	D ₃ = 0.381	L ₃ = 300	z ₃	m ₃	v ₃
4	N ₃	P ₃	N ₁ -N ₄	D ₄ = 0.330	L ₄ = 100	z ₄	m ₄	v ₄
5	N ₄	P ₄	N ₅ -N ₈	D ₅ = 0.330	L ₅ = 200	z ₅	m ₅	v ₅
6	N ₅	P ₅	N ₆ -N ₈	D ₆ = 0.330	L ₆ = 100	z ₆	m ₆	v ₆
7	N ₆	P ₆	N ₇ -N ₈	D ₇ = 0.330	L ₇ = 200	z ₇	m ₇	v ₇
8	N ₇	P ₇	N ₈ - N ₉	D ₈ = 0.838	L ₈ = 10 ⁵	z ₈	m ₈	v ₈
9	N ₈	P ₈	N ₉ - N ₁₀	D ₉ = 0.381	L ₉ = 100	z ₉	m ₉	v ₉
10	N ₉	P ₉	N ₉ - N ₁₁	D ₁₀ = 0.330	L ₁₀ = 100	z ₁₀	m ₁₀	v ₁₀
11	N ₁₀	P ₁₀	N ₉ - N ₁₂	D ₁₁ = 0.432	L ₁₁ = 100	z ₁₁	m ₁₁	v ₁₁
12	N ₁₁	P ₁₁	N ₁₂ - N ₁₆	D ₁₂ = 0.330	L ₁₂ = 100	z ₁₂	m ₁₂	v ₁₂
13	N ₁₂	P ₁₂	N ₁₄ - N ₁₆	D ₁₃ = 0.330	L ₁₃ = 400	z ₁₃	m ₁₃	v ₁₃
14	N ₁₃	P ₁₃	N ₁₅ - N ₁₆	D ₁₄ = 0.330	L ₁₄ = 100	z ₁₄	m ₁₄	v ₁₄
15	N ₁₄	P ₁₄	N ₁₆ - N ₁₇	D ₁₅ = 0.889	L ₁₅ = 10 ⁵	z ₁₅	m ₁₅	v ₁₅
16	N ₁₅	P ₁₅	-----	-----	-----	----	----	-----

17	N_{16}	P_{16}	-----	-----	-----	---	---	-----
18	N_{17}	P_{17}	-----	-----	-----	---	---	-----

Table 3.2: Notation for Compressor Station

S. No.	Compressor	Discharge to Suction Pressure	Isentropic Head Across Compressors	Rotational Speed of Compressors	Efficiency of Compressors	Fuel Consumed in Compressors
1	C_1	P_5/P_2	h_1	w_1	η_1	m_{f1}
2	C_2	P_6/P_3	h_2	w_2	η_2	m_{f2}
3	C_3	P_7/P_4	h_3	w_3	η_3	m_{f3}
4	C_4	P_{13}/P_{10}	h_4	w_4	η_4	m_{f4}
5	C_5	P_{14}/P_{11}	h_5	w_5	η_5	m_{f5}
6	C_6	P_{15}/P_{12}	h_6	w_6	η_6	m_{f6}

Table 3.3: Characteristics of Natural Gas moving in Network 1 (Tabkhi, 2007)

Component	Methane	Ethane	Propane
Mole Percent	70	25	5
Molecular Wt.	16.04	30.07	44.1
Critical Temp., K	190.6	305.4	369.8
Critical Press., bar	46	48.8	42.5
LHV, KJ/kg	50009	47794	46357
C _p , KJ/ kmol*K	35.663	52.848	74.916

3.3.1b Mathematical Formulation

Following section reviews the mathematical equations that have been used for gas pipeline Network 1. First the equations used for estimating natural gas properties are presented. Then the equations for equality and inequality constraints on the network have been presented. Equations that have been taken from section 3.1 and 3.2 have been given reference accordingly.

3.3.1c Equations for Natural Gas Property Estimation

Following section considers the equations used for both the single and bi-objective optimization problem.

$$M = M_1 \times y_1 + M_2 \times y_2 + M_3 \times y_3 \quad (3.01)$$

$$T_C = T_{C1} \times y_1 + T_{C2} \times y_2 + T_{C3} \times y_3 \quad (3.05)$$

$$P_C = P_{C1} \times y_1 + P_{C2} \times y_2 + P_{C3} \times y_3 \quad (3.06)$$

$$H_m = (H_1 \times y_1 \times M_1) + (H_2 \times y_2 \times M_2) + (H_3 \times y_3 \times M_3) \quad (3.07)$$

$$k = \frac{(C_{p1} \times y_1 + C_{p2} \times y_2 + C_{p3} \times y_3)}{(C_{p1} \times y_1 + C_{p2} \times y_2 + C_{p3} \times y_3) - R} \quad (3.31)$$

Equation (3.08) is used for calculating density in pipe arcs.

$$\rho_i = \frac{P_{ij} \times M}{Z_i \times R \times T} \quad (3.08)$$

Equation (3.09) is used for calculating compressibility factor in pipe arc

$$z_i = 1 + \left(0.257 - 0.533 \times \frac{T_C}{T} \right) \times \frac{P_{ij}}{P_C} \quad (3.09)$$

Equation (3.12) is used for calculating mass of gas in pipe arcs.

$$m_i = \rho_i \times Q_i \quad (3.12)$$

Equation (3.25) is used for calculating friction factor in pipe arc.

$$f_i = -2 \log_{10} \left(\frac{e}{3.71 \times D_i} \right)^{-2} \quad (3.25)$$

Equation (3.26) is used for calculating average pressure in pipe arcs.

$$P_{ij} = \left(\frac{2}{3} \right) \times \left[P_i + P_j - \frac{P_i \times P_j}{P_i + P_j} \right] \quad (3.26)$$

Equation (3.29) is used for calculating velocity of gas in pipe arcs.

$$v_i = 14.7359 \times \left(\frac{Q_i \times 24 \times 3600}{(D_o \times 10^3 - 2 \times t_i \times 10^3)^2} \right) \times \left(\frac{P_b}{T_b} \right) \times \left(\frac{z_i \times T}{P_{ij} \times 10^2} \right) \quad (3.29)$$

Equations (3.08), (3.09), (3.26), (3.29) are generalized equations that have been applied to each of the fifteen pipe arc gas pipeline network systems. Individual equations for each pipeline arc have been mentioned in Supplementary Table 1, 2, 3, and 4. Similarly equation (3.12) and (3.25) can be also written for each of the pipeline arc.

3.3.1 d Equality Constraints

Following section demonstrates the equality constraints used in pipeline network.

Equations (3.44 - 3.53) are general mass balance equations that have been obtained by applying the mass balance on each junction of the pipeline network. Equation (3.17) is the pressure drop equation applied to each pipeline segment. Equation (3.35) is the isentropic head equation and Equation (3.36) is an isentropic efficiency equation (Tabkhi, 2007; Smith, J. & Van Ness 1998).

$$m_1 = m_2 + m_3 + m_4 \quad (3.44)$$

$$m_2 = m_{f_1} + m_5 \quad (3.45)$$

$$m_3 = m_{f_2} + m_6 \quad (3.46)$$

$$m_4 = m_{f_3} + m_7 \quad (3.47)$$

$$m_8 = m_5 + m_6 + m_7 \quad (3.48)$$

$$m_8 = m_9 + m_{10} + m_{11} \quad (3.49)$$

$$m_9 = m_{f_4} + m_{12} \quad (3.50)$$

$$m_{10} = m_{f_5} + m_{13} \quad (3.51)$$

$$m_{11} = m_{f_6} + m_{14} \quad (3.52)$$

$$m_{15} = m_{12} + m_{13} + m_{14} \quad (3.53)$$

Equation (3.17) is used for calculating the pressure drop in pipe arc.

$$P_i^2 - P_j^2 = \left[\frac{32 \times m_i^2 \times z_i \times R \times T \times \log_{10} \left(\frac{P_i}{P_j} \right)}{\pi^2 \times D_i^4 \times M} \right] - \left(\frac{16 \times f_i \times z_i \times R \times T \times m_i^2 \times L_i}{\pi^2 \times D_i^5 \times M} \right) \quad (3.17)$$

The above equation has been applied to each of the fifteen pipe arcs and is mentioned in Supplementary Table 5.

Equation (3.35) is used for calculating isentropic head across compressors.

$$h_{ij} = \left(\frac{z_i \times R \times T}{M} \right) \times \left(\frac{k}{k-1} \right) \times \left[\left(\frac{P_j}{P_i} \right)^{\frac{k-1}{k}} - 1 \right] \quad (3.35)$$

Equation (3.36) is used for calculating isentropic efficiency of compressors.

$$\eta_{ij} = \frac{\left(\frac{P_j}{P_i}\right)^{\frac{k-1}{k}} - 1}{\left(\frac{P_j}{P_i}\right)^{\frac{n_p-1}{n_p}} - 1} \quad (3.36)$$

Equation (3.35) and (3.36) are applicable to all the six compressors and are mentioned in Supplementary Table 6 and 7.

3.3.1e Inequality Constraints

Following section demonstrates inequality constraints used in gas pipeline network.

Equation (3.28) represents the pressure limits of the gas in pipeline segments.

$$P_{MAOP,i} = \frac{2 \times t_i \times S \times E \times F \times T'}{D_i} \quad (3.28)$$

The pipeline is considered as a Cross Country, Class 1 location, seamless pipeline. The temperature of the gas moving in the pipeline is fixed at 57⁰ C (330K).

Hence,

Safety Factor F = 0.72;

Efficiency of Pipeline = 1

Temperature De-rating factor = 1

Pipe Grade X42.

Equation (3.33) is used for calculating upper bounds of velocity in pipe arcs.

$$v_{ei} \leq 122 \sqrt{\frac{z_i \times R \times T}{P_{ij} \times M}} \quad (3.33)$$

Equations (3.28) and (3.33) are generalized equations applicable to all the fifteen pipe arcs. These equations have been mentioned in Supplementary Table 8 and 9.

Equation (3.43) is used for calculating the upper limit of inlet flow at compressor to

avoid choking. The equation is applicable to all the six compressors and is mentioned in Supplementary Table 10.

$$Q_s \leq \left(\frac{\pi D^2}{4} \right) \times c_i \times \left(\frac{2}{k+1} \right)^{\frac{k+1}{2(k-1)}} \quad (3.43)$$

$$c_i = \sqrt{\frac{k \times z_i \times R \times T}{M}} \quad (3.30)$$

Equation (3.54) is the generalized equation used for calculating lower and upper bounds of rotational speed of compressors.

$$166.7 < w_i < 450$$

(3.54)

Equation (3.39) is used for calculating fuel consumption in compressors.

$$m_f = \left(\frac{m_j \times h_{ij}}{H_m} \right) \times \left(\frac{10^2}{\eta_{is}} \times \frac{10^2}{\eta_d} \times \frac{10^2}{\eta_m} \right)$$

(3.39)

Similar equation can be written for calculating fuel consumption in all the six compressors.

Mechanical Efficiency and Driver Efficiency are kept fixed at 0.9 and 0.35 respectively (Tabkhi, 2007).

3.3.1f Model Validations

The model differs from the earlier model (Tabkhi, 2007), as it considers isentropic head and efficiency as a function of discharge and suction pressure at the compressors instead of rotational speed. Further in the present work rotational speed

has been considered as the action variable. The model is validated using pressure and mass flow rate values of Generalized Reduced Gradient method (GRG) (Tabkhi, 2007), to calculate the fuel consumed in each compressor. These values are compared with fuel consumed in the earlier case (Tabkhi, 2007), in Table 3.4. The closeness of both numbers as is seen in Table 3.4, establishes the utility of the current model.

Table 3.4: Prediction of fuel consumption for comparison of Tabkhi Model with our model (Using $n_p = 1.313$)

S. No.	Compressor No.	Tabkhi Model	Present Model
1	Compressor 1	0.1800	0.1887
2	Compressor 2	0.1900	0.1917
3	Compressor 3	0.1900	0.1923
4	Compressor 4	0.0600	0.0587
5	Compressor 5	0.0700	0.0612
6	Compressor 6	0.0600	0.0586
	Total Fuel Consumed	0.7500	0.7512

Problem 1: Single - Objective Optimization

Following is the general definition of minimizing a single objective function (Deb,2003):

Minimize $f(x)$: Where, $x = [x_1, x_2, x_3 \dots x_n]$ is the vector containing optimization variables

Subjected to

$$g_i(x) = 0, \quad 1 \dots m \quad (\text{Equality Constraints})$$

$$h_j(x) \geq 0 \quad j = 1 \dots n \quad (\text{Inequality Constraints})$$

The objective function as described above is subject to equality and inequality constraints which will be discussed in the preceding sections.

Minimizing fuel consumption in compressors for fixed throughput is the single objective optimization function. Ant Colony an evolutionary technique has been used for minimizing the objective function.

Objective

$$\min f(m_i, P_i, P_j) = \min \sum m_f = \sum_{i,j \in A_c} \left(\frac{m_j \times h_{ij}}{H_m} \right) \times \left(\frac{10^2}{\eta_{is}} \times \frac{10^2}{\eta_d} \times \frac{10^2}{\eta_m} \right) \quad (3.39)$$

Problem 2: Multi-Objective Optimization

Optimization of pipeline operations sometimes requires optimization of more than one objective of conflicting nature: for instance, one objective can be minimizing line pack and maximizing throughput from the gas pipeline network system (Botros, K. 2004). Similar a very interesting problem is the minimization of fuel consumed to operate the pipeline system and at the same time a second objective might be maximization of throughput of gas. This is the problem considered for the

bi-objective optimization problem in this thesis. Optimal solutions to one objective may contradict optimal solutions of the other objective; therefore, a solution to the problem will entail mutual sacrifice (trade-off) of objectives. Pareto dominance is studied and tested with common test functions available in optimization literature.

Objective 1: Minimizing fuel consumption in compressors.

$$f_1(x) = \min \sum m_{fi}$$

Where

$$\min \sum m_{fi} = \min \sum_{i,j \in A_c} \left(\frac{m_j \times h_{ij}}{H_m} \right) \times \left(\frac{10^2}{\eta_{is}} \times \frac{10^2}{\eta_d} \times \frac{10^2}{\eta_m} \right) \quad (3.39a)$$

Objective 2: Maximizing throughput (m_{15}) at the delivery station.

$$f_2(x) = \max(m_{15}) \quad (3.39b)$$

3.3.2 Network 2: Multi Source and Multi Delivery Pipeline Network System

3.3.2a Network Description

Network 2 is more complicated than the previous gas pipeline network problem, but involves the same formulation as the previous one. This case study was obtained from French Company, Gaz De France and is inspired from the real data. Tabkhi, 2007 first used Generalized Reduced Gradient Technique of CONOPT Solver, in GAMS software to minimize the fuel consumption in compressors. Here the use of valves is included which is used to vary the flow along the pipes. Figure 3.3 shows the gas pipeline network. The network consists of thirty pipeline arcs connecting six supply points to nineteen delivery stations. In the figure supply points have been symbolized by black hexagon and delivery points by black circles. Seven intermediate compressor stations operate to compensate for pressure drop in pipelines. Twenty intermediate nodes symbolized by black circles provide necessary interconnections between two either different diameter pipelines or different pressure limits. The whole gas pipeline network consists of forty five (twenty intermediate nodes + six supply points + nineteen delivery points) nodes and thirty pipeline arcs. Ten valves are used to break the pressure between some pair of points in order to balance the network. Sometimes these valves are also positioned just after the compressors to regulate the output pressure of two or more streams that originate from the discharge side of compressors. The arc wise list of length, diameter, maximum allowable operating pressure (MAOP) and roughness is listed in Table 3.5.

Node wise list for lower and upper limit of pressure is listed in Table 3.6. $N_1, N_4, N_{20}, N_{30}, N_{39}$ and N_{45} are gas supply nodes.

$N_2, N_3, N_5, N_6, N_9, N_{10}, N_{12}, N_{14}, N_{16}, N_{19}, N_{22}, N_{23}, N_{25}, N_{31}, N_{33}, N_{35}, N_{37}, N_{40}, N_{44}$

are gas delivery nodes. Table 3.7 represents the maximum supply at supply nodes and minimum fixed delivery at the delivery nodes (Tabkhi, 2007). Table 3.8 represents the characteristics of compressors (Tabkhi, 2007). Properties of Natural gas have been mentioned in Table 3.9. The whole network involves ninety eight variables (forty five pressure variables + thirty mass rate variables + ten mass rate variables in valves + six gas supply rate variables at the source station + seven fuel consumption variables). The gas delivered at the nineteen delivery stations remains fixed.

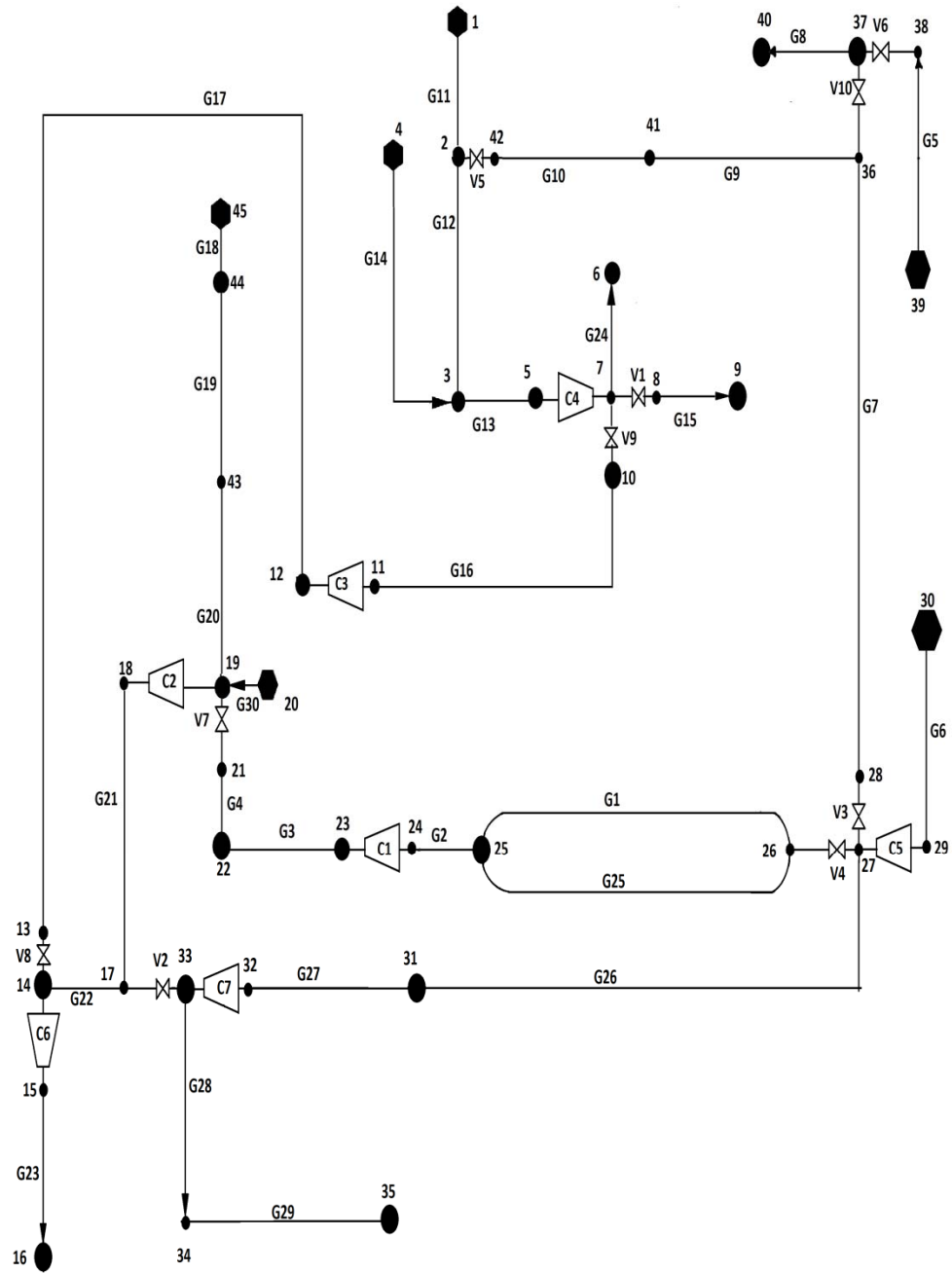

Fig. 3.3 Multi-Source, Multi- Delivery Gas Pipeline Network System

Table 3.5 Arc-wise List of Gas Pipeline Network

Pipeline Network	Symbol	Diameter (mm)	Length (km)	MAOP (bar)	Roughness (μm)	Arc	Symbol	Diameter (mm)	Length (km)	MAOP (bar)	Roughness (μm)
1	G ₁	754	64.1	68.7	20	14	G ₁₆	595	46.8	68	10
2	G ₂	688	101.6	68.7	20	15	G ₁₇	588	27.9	56.8	10
3	G ₃	681	80.4	68	10	16	G ₁₈	744	95.7	68	10
4	G ₄	617	27.1	68	10	17	G ₁₉	744	119.7	68	10
5	G ₅	1090	172.7	85	10	18	G ₂₀	892	4.9	80	10
6	G ₆	1167	4.9	68	10	19	G ₂₁	1167	30.9	80	10
7	G ₇	1069	122.2	68	10	20	G ₂₂	892	53.4	80	10
8	G ₈	895	81.3	68	10	21	G ₂₃	892	54.5	68	10
9	G ₉	1069	41.6	68	10	22	G ₂₄	892	77	68	10
10	G ₁₀	1054	28.4	68	10	23	G ₂₅	794	89	68	10
11	G ₁₁	874	21.6	68	10	24	G ₂₆	493	63.9	68	20
12	G ₁₂	954	14.2	68	10	25	G ₂₇	994	64.1	68.7	10
13	G ₁₃	948	43.3	68	10	26	G ₂₈	994	204.5	68	10
14	G ₁₄	994	36.2	68	10	29	G ₂₉	891	67.7	85	10
15	G ₁₅	891	125.8	85	10	30	G ₃₀	1000	0.001	68.7	10

Table 3.6 Nodal Characteristics of Pipeline Network System (Tabkhi, 2007)

S. No.	Node	Pressure Range (bar)	S. No.	Node	Pressure Range (bar)	S. No.	Node	Pressure Range (bar)
1	N_1	$40 < P_1 < 49$	17	N_{17}	$40 < P_{17} < 68.7$	33	N_{33}	$40 < P_{33} < 86$
2	N_2	$40 < P_2 < 68.7$	18	N_{18}	$40 < P_{18} < 68.7$	34	N_{34}	$40 < P_{34} < 86$
3	N_3	$40 < P_3 < 68.7$	19	N_{19}	$40 < P_{19} < 68.7$	35	N_{35}	$61 < P_{35} < 86$
4	N_4	$40 < P_4 < 68.7$	20	N_{20}	$40 < P_{20} < 68.7$	36	N_{36}	$40 < P_{36} < 68.7$
5	N_5	$40 < P_5 < 68.7$	21	N_{21}	$40 < P_{21} < 68.7$	37	N_{37}	$40 < P_{37} < 68.7$
6	N_6	$40 < P_6 < 68.7$	22	N_{22}	$40 < P_{22} < 68.7$	38	N_{38}	$60 < P_{38} < 86$
7	N_7	$40 < P_7 < 68.7$	23	N_{23}	$40 < P_{23} < 68.7$	39	N_{39}	$P_{39} = 85$
8	N_8	$40 < P_8 < 56.8$	24	N_{24}	$40 < P_{24} < 68.7$	40	N_{40}	$40 < P_{40} < 68.7$
9	N_9	$40 < P_9 < 56.8$	25	N_{25}	$40 < P_{25} < 68.7$	41	N_{41}	$40 < P_{41} < 68.7$
10	N_{10}	$40 < P_{10} < 68.7$	26	N_{26}	$40 < P_{26} < 68.7$	42	N_{42}	$40 < P_{42} < 68.7$
11	N_{11}	$40 < P_{11} < 68.7$	27	N_{27}	$40 < P_{27} < 68.7$	43	N_{43}	$40 < P_{43} < 81$
12	N_{12}	$40 < P_{12} < 68.7$	28	N_{28}	$40 < P_{28} < 68.7$	44	N_{44}	$40 < P_{44} < 81$
13	N_{13}	$40 < P_{13} < 68.7$	29	N_{29}	$40 < P_{29} < 68.7$	45	N_{45}	$40 < P_{45} < 81$
14	N_{14}	$40 < P_{14} < 68.7$	30	N_{30}	$40 < P_{30} < 67$	16	N_{16}	$40 < P_{16} < 68.7$
15	N_{15}	$40 < P_{15} < 68.7$	31	N_{31}	$40 < P_{31} < 68.7$	32	N_{32}	$40 < P_{32} < 86$

**Table 3.7: Values of Maximum Supply and Minimum Delivery
(Tabkhi, 2007)**

S. No.	Node	Symbol	Maximum Gas Supply (kg/s)	Minimum Gas Delivery (kg/s)	S. No.	Node	Symbol	Maximum Gas Supply (kg/s)	Minimum Gas Delivery (kg/s)
1	N_1	ms ₁	78.406	--	16	N_{25}	mde ₂₅	--	63.628
2	N_2	mde ₂	--	75.678	17	N_{30}	ms ₃₀	474.331	--
3	N_3	mde ₃	--	146.964	18	N_{31}	mde ₃₁	--	0.393
4	N_4	ms ₄	68.652	--	19	N_{33}	mde ₃₃	--	6.866
5	N_5	mde ₅	--	36.824	20	N_{35}	mde ₃₅	--	172.76
6	N_6	mde ₆	--	42.596	21	N_{37}	mde ₃₇	--	62.274
7	N_9	mde ₉	--	23.011	22	N_{39}	ms ₃₉	400.564	--
8	N_{10}	mde ₁₀	--	19.987	23	N_{40}	mde ₄₀	--	126.622
9	N_{12}	mde ₁₂	--	20.436	24	N_{44}	mde ₄₄	--	73.574
10	N_{14}	mde ₁₄	--	41.693	25	N_{45}	ms ₄₅	190.786	--
11	N_{16}	mde ₁₆	--	42.064					
12	N_{19}	mde ₁₉	--	119.988					
13	N_{20}	ms ₂₀	53.377	--					
14	N_{22}	mde ₂₂	--	59.507					
15	N_{23}	mde ₂₃	--	16.15					

Table 3.8: Principal Characteristics of the compressors (Tabkhi, 2007)

S. No.	Compressor	MAOP at Outlet Node of Compressors (bar)	Maximum Capacity at inlet of compressor (m ³ /s)
1	C_1	$P_{24} < 80$	$q_{24} < 1.56 * 10^2$
2	C_2	$P_{19} < 80$	$q_{19} < 4.86 * 10^2$
3	C_3	$P_{11} < 80$	$q_{11} < 2.08 * 10^2$
4	C_4	$P_5 < 80$	$q_5 < 2.67 * 10^2$
5	C_5	$P_{29} < 80$	$q_{29} < 6.67 * 10^2$
6	C_6	$P_{14} < 80$	$q_{14} < 3.78 * 10^2$
7	C_7	$P_{32} < 86$	$q_{32} < 2.64 * 10^2$

Table 3.9 Characteristics of Natural Gas moving in Network 2 (Tabkhi, 2007)

S. No.	Gas Mixture Property	Values
1	Composition of gas	Methane = 91%, Ethane = 9%
2	Heating Value (KJ/m ³)	4.18* 10 ⁴
3	Specific Gravity	0.6
4	Gas Temperature, K	278.15
5	Heat Capacity Ratio	1.309

3.2b Mathematical Formulation

Following section presents the mathematical equations used in the second gas pipeline network. First equations used for estimating natural gas properties have been presented. Then the equations for equality and inequality constraints have been presented. Equations that have been taken from section 3.1 and 3.2 have been referenced accordingly.

Equations for Natural Gas Property Calculation:

$$M = M_1 \times y_1 + M_2 \times y_2 \quad (3.01)$$

$$T_C = T_{C1} \times y_1 + T_{C2} \times y_2 \quad (3.05)$$

$$P_C = P_{C1} \times y_1 + P_{C2} \times y_2 \quad (3.06)$$

Equation (3.08) is the generalized equation used for calculating density of gas in pipe arcs. Equation (3.09) is the generalized equation for calculating compressibility factor in pipe arc. Equation (3.12) is used is used for calculating the mass rate in pipe arcs. Equation (3.25) is the generalized equation used for calculating friction factor in pipe arc. Equation (3.26) is used for calculating average pressure in pipe arc. Equation (3.29) is used for calculating velocity in pipe arcs.

$$\rho_i = \frac{P_{ij} \times M}{Z_i \times R \times T} \quad (3.08)$$

$$z_i = 1 + \left(0.257 - 0.533 \times \frac{T_C}{T} \right) \times \frac{P_{ij}}{P_C}$$

(3.09)

$$m_i = \rho_i \times Q_i \quad (3.12)$$

$$f_i = -2 \log_{10} \left(\frac{e}{3.71 \times D_i} \right)^{-2}$$

(3.25)

$$P_{ij} = \left(\frac{2}{3} \right) \times \left[P_i + P_j - \frac{P_i \times P_j}{P_i + P_j} \right] \quad (3.26)$$

$$v_i = 14.7359 \times \left(\frac{Q_i \times 24 \times 3600}{(D_i \times 10^3 - 2 \times t_i \times 10^3)^2} \right) \times \left(\frac{P_b}{T_b} \right) \times \left(\frac{z_i \times T}{P_{ij} \times 10^2} \right)$$

(3.29)

$$k = \frac{(C_{p1} \times y_1 + C_{p2} \times y_2)}{(C_{p1} \times y_1 + C_{p2} \times y_2) - R} \quad (3.31)$$

Equation for Average Pressure and Compressibility Factor for each pipe arc have been presented in Supplementary Table 11 and 12.

Similar equation for density of gas, mass flow rate, friction factor, velocity of gas in each of the pipe arc can be written.

Equality Constraints

Following section demonstrates the equality constraint used in the pipeline network.

Equation (3.55 – 3.92) are the general mass balance equation applied to each of the pipe nodes.

$$m_1 + m_{25} = m_{de25} + m_2 + m_{f1} \quad (3.55)$$

$$m_3 = m_2 - m_{de23} \quad (3.56)$$

$$m_4 = m_3 - m_{de22} \quad (3.57)$$

$$m_{20} + m_{30} + V_7 - m_{de19} - m_{f2} = m_{21} \quad (3.58)$$

$$m_{18} = m_{19} + m_{de44} \quad (3.59)$$

$$m_{20} = m_{19} \quad (3.60)$$

$$m_{22} = m_{21} \quad (3.61)$$

$$m_{23} = m_{22} - V_8 - m_{de14} - m_{f6} \quad (3.62)$$

$$m_{13} = m_{12} + m_{14} - m_{de23} \quad (3.63)$$

$$m_{12} = m_{11} + V_5 - m_{de2} \quad (3.64)$$

$$m_{29} = m_{28} \quad (3.65)$$

$$m_{29} = m_{de35} \quad (3.66)$$

$$m_{28} = m_{27} - m_{f7} - m_{de33} \quad (3.67)$$

$$V_6 - m_{de37} - m_8 = V_{10} \quad (3.68)$$

$$m_9 = m_{10} \quad (3.69)$$

$$m_8 = m_{de40} \quad (3.70)$$

$$m_{24} = m_{13} - m_{de5} - m_{f4} - V_1 - V_9 \quad (3.71)$$

$$m_{24} = m_{de6} \quad (3.72)$$

$$m_{15} = m_{de9} \quad (3.73)$$

$$m_{23} = m_{de16} \quad (3.74)$$

$$V_3 + V_4 + m_{26} = m_6 - m_{f5} \quad (3.75)$$

$$m_{27} = m_{26} - m_{de31} \quad (3.76)$$

$$m_{17} + m_{16} = m_{de12} - m_{f3} \quad (3.77)$$

$$m_{15} = V_1 \quad (3.78)$$

$$V_9 = m_{16} - m_{de10} \quad (3.79)$$

$$m_{11} = m_{s1} \quad (3.80)$$

$$m_6 = m_{s30} \quad (3.81)$$

$$m_{30} = m_{s20} \quad (3.82)$$

$$m_{18} = m_{s45} \quad (3.83)$$

$$m_5 = m_{s39} \quad (3.84)$$

$$m_7 + V_{10} = m_9 \quad (3.85)$$

$$m_7 = V_3 \quad (3.86)$$

$$V_4 = m_1 - m_{25} \quad (3.87)$$

$$m_5 = V_6 \quad (3.88)$$

$$m_{10} = V_5 \quad (3.89)$$

$$V_7 = m_4 \quad (3.90)$$

$$V_2 = 0 \quad (3.91)$$

$$V_8 = m_{17} \quad (3.92)$$

Equation (3.17) is used for calculating pressure drop in pipe arc. The equation is applicable to each of the pipeline arc and have been reported separately for each arc in Supplementary Table 13.

$$P_i^2 - P_j^2 = \left(\frac{32 \times m_i^2 \times z_i \times R \times T \times \log_{10} \left(\frac{P_i}{P_j} \right)}{\pi^2 \times D_i^4 \times M} \right) - \left(\frac{16 \times f_i \times z_i \times R \times T \times m_i^2 \times L_i}{\pi^2 \times D_i^5 \times M} \right) \quad (3.17)$$

Isentropic head across compressors is calculated from equation (3.35).

$$h_{ij} = \left(\frac{z_i \times R \times T}{M} \right) \times \left(\frac{k}{k-1} \right) \times \left[\left(\frac{P_j}{P_i} \right)^{\frac{k-1}{k}} - 1 \right] \quad (3.35)$$

Individual isentropic head equations for each of the compressors have been

presented in Supplementary Table 14.

Isetropic efficiency of compressor is obtained from the equation (3.42).

$$\eta_i = \frac{\left(\frac{P_j}{P_i}\right)^{\frac{k-1}{k}} - 1}{\left(\frac{P_j}{P_i}\right)^{\frac{n_p-1}{n_p}} - 1} \quad (3.42)$$

Individual equations for Isetropic Efficiency, for each of the compressors have been presented in Supplementary Table 15.

Inequality Constraints

Following section demonstrates inequality constraints. Equation (3.37) is applicable to each of the pipeline arc and equations (3.48) and (3.49) are applicable to each of the seven compressors respectively.

$$v_i \leq v_{ei} \text{ Where } v_{ei} = 122 \sqrt{\frac{z_i \times R \times T}{P_{ij} \times M}} \quad (3.37)$$

$$q_{i\max} < \left(\frac{\pi}{4} \times D_i^2\right) \times c_i \times \left(\frac{2}{k+1}\right)^{\frac{k+1}{2 \times (k-1)}} \quad (3.48)$$

$$\text{Where } c_i = \sqrt{\frac{k \times z_i \times R \times T}{M}} \quad (3.49)$$

Tables 3.6 gives pressure bounds; Table 3.7 gives maximum gas supply from six nodes, and minimum gas delivery at nineteen delivery points, Table 3.8 maximum operating pressure at the outlet node of compressor and flow rate values to avoid

choking in compressors.

The use of stochastic algorithms such as Ant Colony Algorithms is a very interesting problem as it is well recognized that they can be easily adapted to multiobjective problems. Hence has been used in the present thesis for optimization.

Problem: Single Objective Optimization

Minimizing fuel consumption in the gas pipeline network for fixed throughput at the delivery station is the objective of this work:

$$\min f(m_i, P_i, P_j) = \min \sum m_f = \sum_{i,j \in A_c} \left(\frac{m_j \times h_{ij}}{H_m} \right) \times \left(\frac{10^2}{\eta_{is}} \times \frac{10^2}{\eta_d} \times \frac{10^2}{\eta_m} \right)$$

(3.39)

Variables include forty five numbers of pressure variables at nodes, thirty mass rate variables in pipe arcs, seven fuel consumption rate in compressors, ten flow rate variables in valves and six mass rate variables at supply nodes. A total of ninety eight variables is involved in the problem. The objective is to minimize fuel consumption at the compressor stations for the fixed value of throughput at the delivery stations as is mentioned in Table 4.7.

3.4 Ant Colony Optimization

Ant Colony Optimization is a nature inspired optimization algorithm where populations of agents share some information in order to achieve shortest path. While searching for food, biological ants first start to explore the area around their nest. If a particular ant succeeds in finding food, it returns back to the original nest. In this

process ants lay down a chemical pheromone trail, thus marking its path. This pheromone trail attracts other ants to follow the same path, thus enabling them in finding the same food source again. The basic idea of Ant Colony Algorithms is to mimic this biological behavior with artificial ants, that randomly search at first and then uses some pheromone like parameter to explore the search domain defined by an optimization problem (Dorigo & Stutzle, 2004). In the present work a pheromone triplet consisting of (a) probability of a particular ant to be chosen, (b) mean value of fuel consumption, (c) the standard deviation between the best ant and worst ant, has been used for guiding the next generation of ants to find the optima (Schlueter, 2012). Algorithm for Single Objective Ant Colony Optimization has been presented in Table (3.10) and for Multiobjective Ant Colony Optimization has been presented in Table 3.11. The computational test were performed on a personal computer with Intel (R) Core (TM) 2.4 GHz CPU/2 GB RAM. Coding has been done in MATLAB R 2010.

Table 3.10: Ant Colony Algorithm for Single Objective Optimization

(Stopping Criteria: Maximum Time, Specified Objective function value, Number of Evaluations)

Step 1: Initiate first generation of ants

Step 2: Select ant population size, containing $(x, y)^1, (x, y)^2, (x, y)^3 \dots (x, y)^n$ number of individual's. The population of ant remains same throughout in each iteration.

Step 3: Select Number of best solutions n_{best} using fitness function. These best solutions are to be kept in solution matrix.

Step 4: Construct pheromone triplet that guides the ant to search for optima

Pheromone Triplet contains

Weighted factor: that gives the probability of a particular ant to be chosen.

Mean value: that is based on the ant that has a higher probability to be chosen.

Deviation: that is based on best and worst ants.

Step 5: Using Evolutionary operator to generate the next generation of ants. The ant having higher weight factor is the ant is to be compared with the new generation of ants. The ants, giving better result as compared to the previous ant having highest

weight factor is to be kept in the solution matrix, while others have to be discarded.

Step 6: Evaluate the new generation for fitness. Keep the better ants (n_{best}) in the solution matrix and discard the worst ants.

Step 7: Repeat steps 3 to 6 until ‘stopping criteria’ has been satisfied.

Table 3.11: Ant Colony Algorithm for Multiobjective Optimization

(Stopping Criteria: Maximum Time or Maximum Number of Evaluations)

Step 1: Define the objective functions $f_1(x), f_2(x), \dots, f_p(x)$ and set of equality and non-equality constraints.

Step 2: Combine the multiple objective to a single objective function using Adaptive Weighted Sum method.

Step 3: Now initiate first generation of ants by selecting an ant population size containing $(x, y)^1, (x, y)^2, (x, y)^3, \dots, (x, y)^n$ number of individual's.

Step 4: Select Number of best solutions n_{best} using fitness function. These best solutions are to be kept in solution matrix.

Step 5: Construct pheromone triplet that guides the ant to search for optima.

(Pheromone Triplet contains

- i. *Weighted factor:* that gives the probability of a particular ant to be chosen.
- ii. *Mean value:* that is based on the ant that has a higher probability to be chosen
- iii. *Deviation:* that is based on best and worst ants.

Step 6: Calculate Utopia (at which values of both functions are minimized) and

Nadir points (at which values of both functions is maximized).

Step 7: Evaluate their approximations PF_i and PF_j to the Pareto front. If $i \neq j$ and all constraints are satisfied, use an evolutionary operator to generate the next generation of ants.

Step 8: The ants having higher weight factor are to be compared with the new generation of the ants. The ants, giving a better result (in terms of minimizing the function) as compared to the previous ant having highest weight factor is to be kept in the solution matrix, while others have to be discarded.

Step 9: Evaluate the new generation of fitness. Keep the better ants (m_{best}) in the solution matrix and discard the worse ants.

3.5 Chapter Summary

The present chapter first discussed the general formulation used in Modelling of gas pipeline network. Two case studies with Mathematical formulation were then presented. Finally, Ant colony optimization algorithms were presented both for single and multiobjective optimization. The results obtained for first network have been presented in **Chapter 4** and for second Network have been presented in **Chapter 5**. In both the chapters, comparison of Ant Colony results, obtained by earlier work (Tabkhi, 2007) is used to verify correctness of our work.

Chapter 6 gives the conclusions and perspectives for future works.

CHAPTER 4

SINGLE SOURCE AND SINGLE DELIVERY PIPELINE

NETWORK OPTIMIZATION - RESULTS

In this chapter optimization result of Single Supply - Single Delivery Gas Pipeline Network using Ant Colony Technique is presented. To facilitate the reading Figure 3.3 is reproduced once again. The general mathematical formulation of gas pipeline network presented in chapter 3 is used for optimization. The results of single objective function of minimizing fuel consumption (Equation 3.39) for fixed throughput are first presented. The Result of Multiobjective function (Equation 3.39a and 3.39b) for minimizing fuel consumption and maximizing throughput is then presented.

4.1 Single Objective Optimization Results

4.1.1 Ant Colony Results for Minimizing fuel Consumption in Compressors for fixed Throughput.

The Single Objective Ant Colony Algorithm presented in Table 3.10 is used for optimizing gas pipeline network shown in Figure 3.3. The single objective function of minimizing fuel consumption in compressors for a fixed value of throughput (150 kg/sec) is considered. The Ant Colony Evolutionary technique generates a number of solutions from which the best solutions are saved in the solution matrix. Five ants were initially chosen and three best ants out of five were selected. In the subsequent iterations which throw up three more solutions are compared with earlier three best solutions and three best out of the six are selected thus improving solutions with subsequent iterations. The optimum values of various variables obtained using

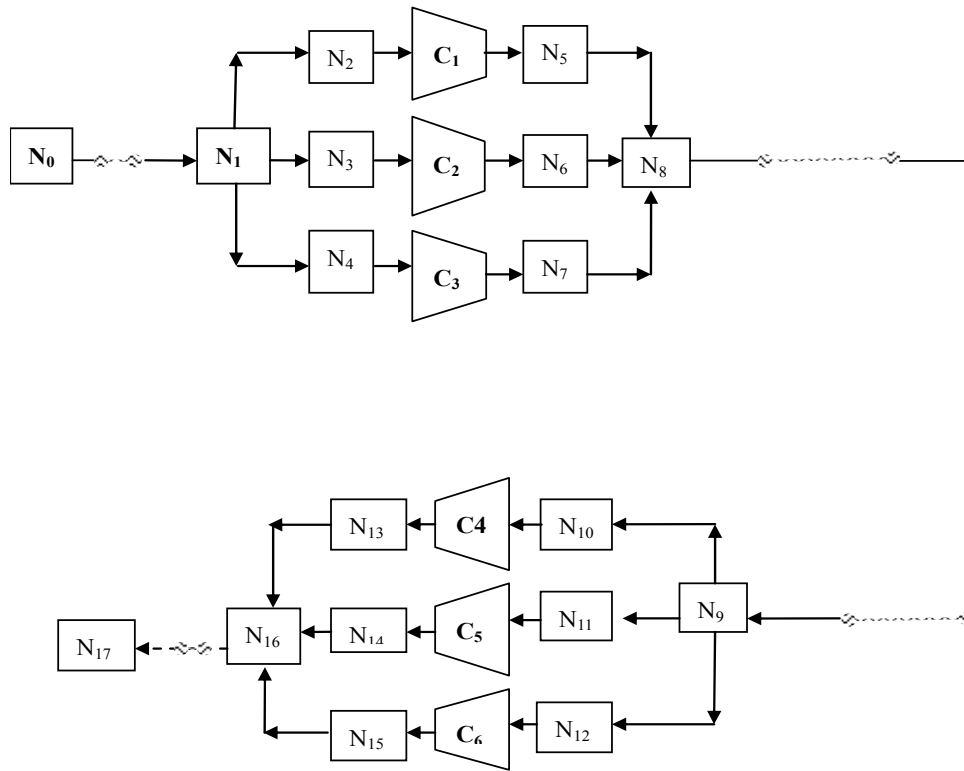

**Fig. 3.3 Single Source and Single Delivery Pipeline Network System
(Reproduced from Chapter 3)**

Single Objective Ant Colony Optimization technique that leads to the minimization of fuel consumption in compressors is presented in Figures 4.1 - 4.6. Comparison of results obtained using Ant Colony Optimization Technique and GRG is presented in Figures 4.7 - 4.12. The results of each optimized variable are now discussed.

The pressure value at individual pipe node is the most important variable as it determines compressor functioning and hence fuel consumption. The optimal pressures obtained using Ant Colony Optimization at different nodes are presented in Figure 4.1. Figure clearly indicates that the algorithm has taken a gas inlet pressure which is slightly lower than the maximum permissible pressure while the delivery pressure is slightly above the lowest permissible value ($60 \pm 2\%$). This ensures a safer operation of gas pipeline network. At the delivery station if a lower pressure is required, then a regulating valve can be used to regulate the pressure.

Before we compare the fuel consumption, we must compare other aspects of our solution. The first being amount of gas throughput of the gas pipeline network, which is fixed at 150 kg per second. The results shown in Figure 4.2 indicate that the result obtained using ACO comply with the requirement. Figure 4.2 also indicates the values of gas flow rate in pipe arcs.

It can be clearly seen in the figure that the mass rate in Pipe arc G1 is equal to the sum of mass gas flow rate in arc G2, G3 and G4. Hence the mass balance at Node 1 is satisfied. Similarly, mass balance at other nodes N8, N9, N16 are also satisfied.

The optimum rotational speeds of various compressors have been shown in Figure

4.3.

As mentioned in equation 3.54 (Chapter 3), lower and upper limits of rotational speed of compressors are 166.7 and 450 rps respectively. The results obtained using Ant Colony technique for rotational speed as shown in figure are within the limits mentioned.

Isentropic head is another variable that plays an important role in determining compressor characteristics and is used for calculating fuel consumption in compressors. The optimum results of isentropic heads across compressors are shown in Figure 4.4.

Apart from driver efficiency and mechanical efficiency, isentropic efficiency is also used for calculating fuel consumption in compressors. The driver and mechanical efficiency of the compressors is already fixed, while isentropic efficiency varies with compression ratio. The values of isentropic efficiency obtained using an Ant Colony optimization technique have been shown in Figure 4.5.

Finally the results of fuel consumption in compressors obtained using Ant Colony Optimization technique have been presented in Figure 4.6.

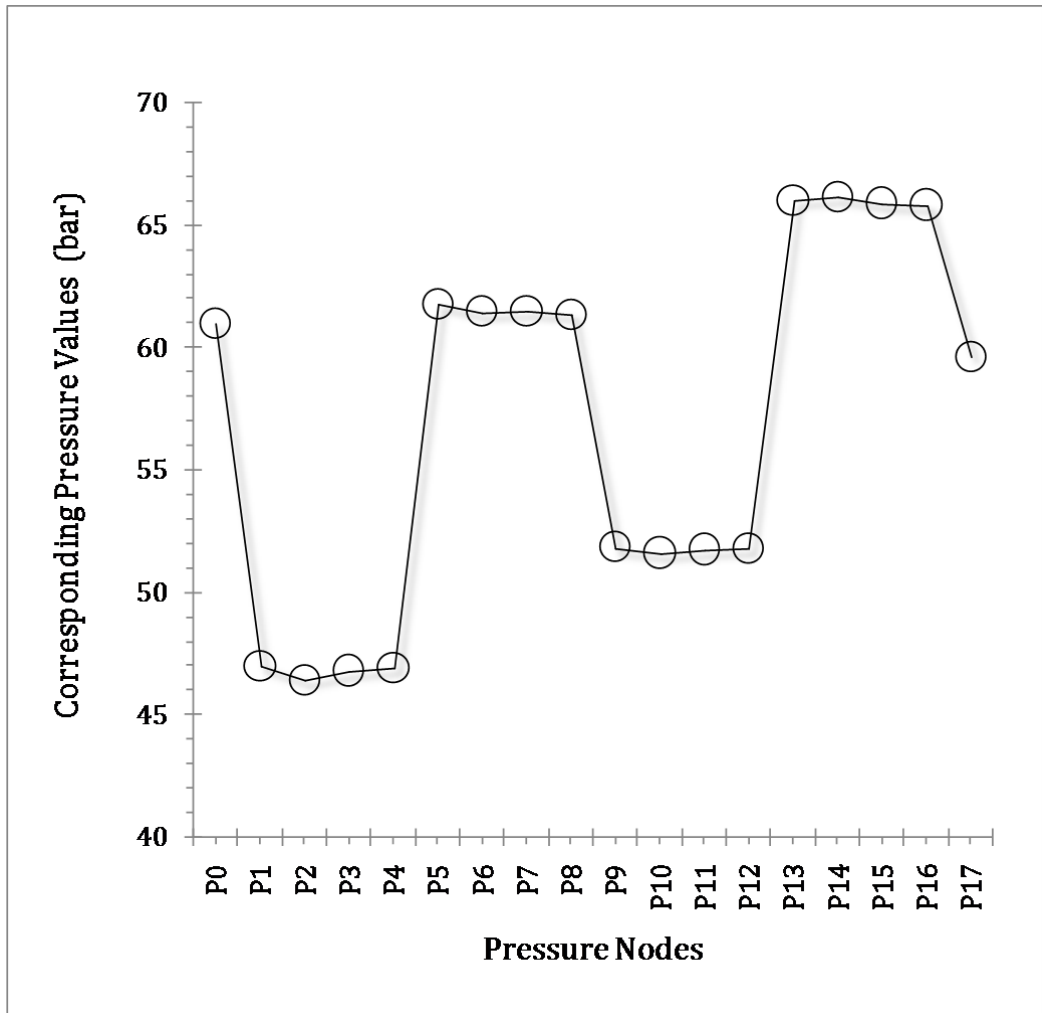

Fig. 4.1: Optimum Pressure Values at Eighteen Pipe Nodes obtained using ACO

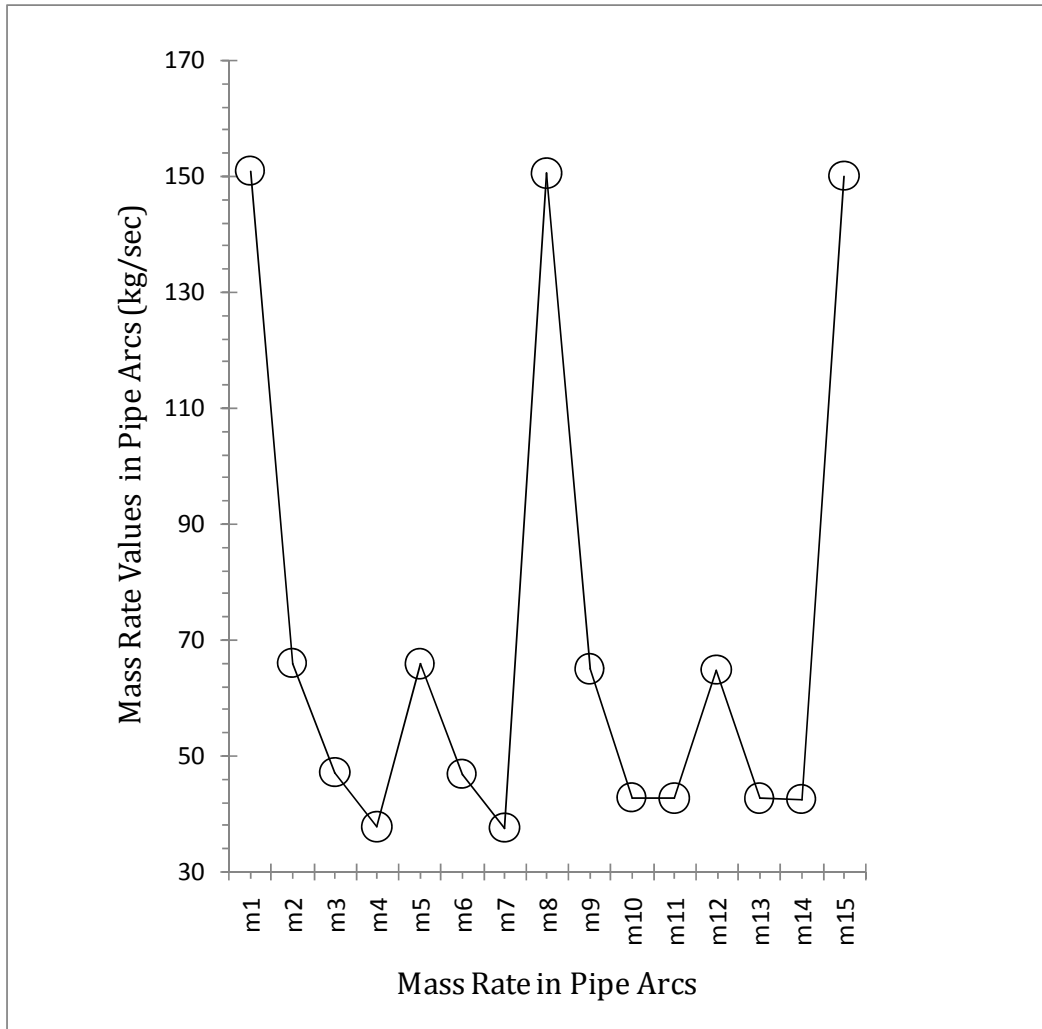

Fig.4.2: Optimum Gas Mass Rate in Fifteen Pipe Arcs as obtained using ACO

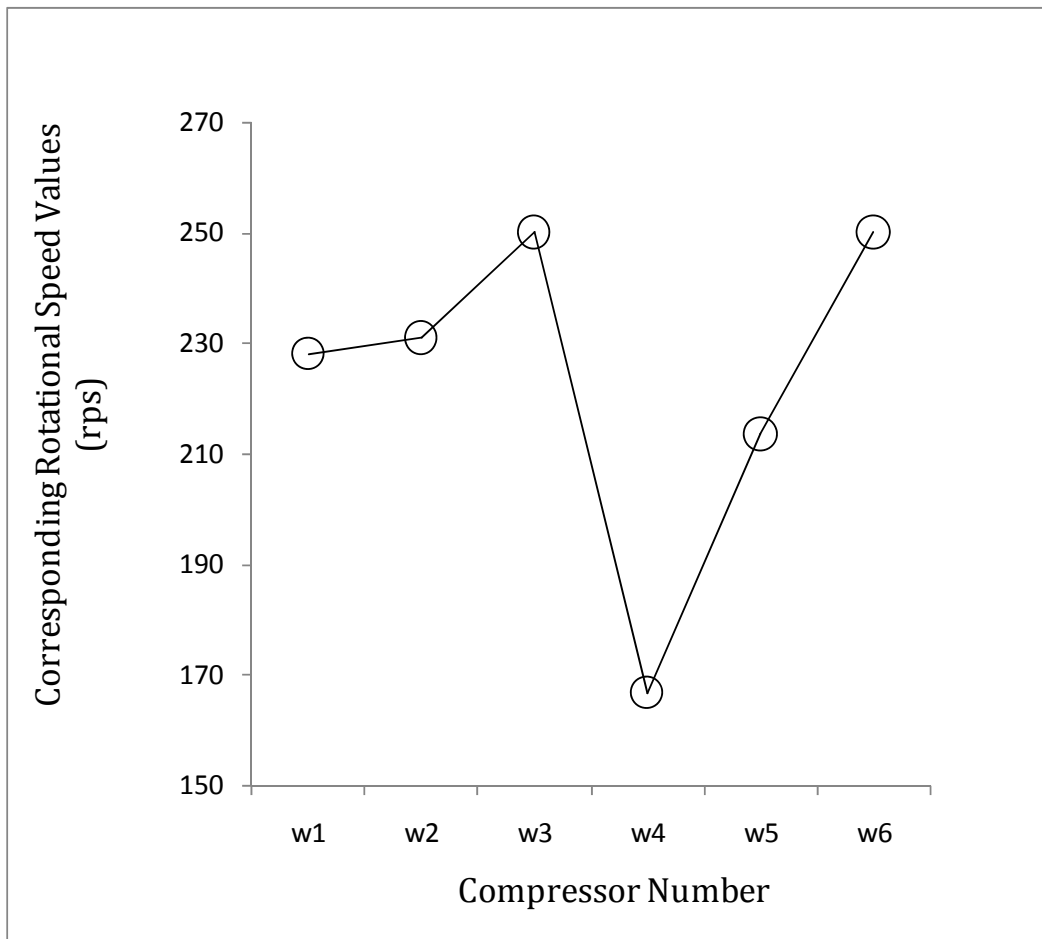

Fig.4.3: Optimum Rotational Speed of Six Compressors obtained using ACO

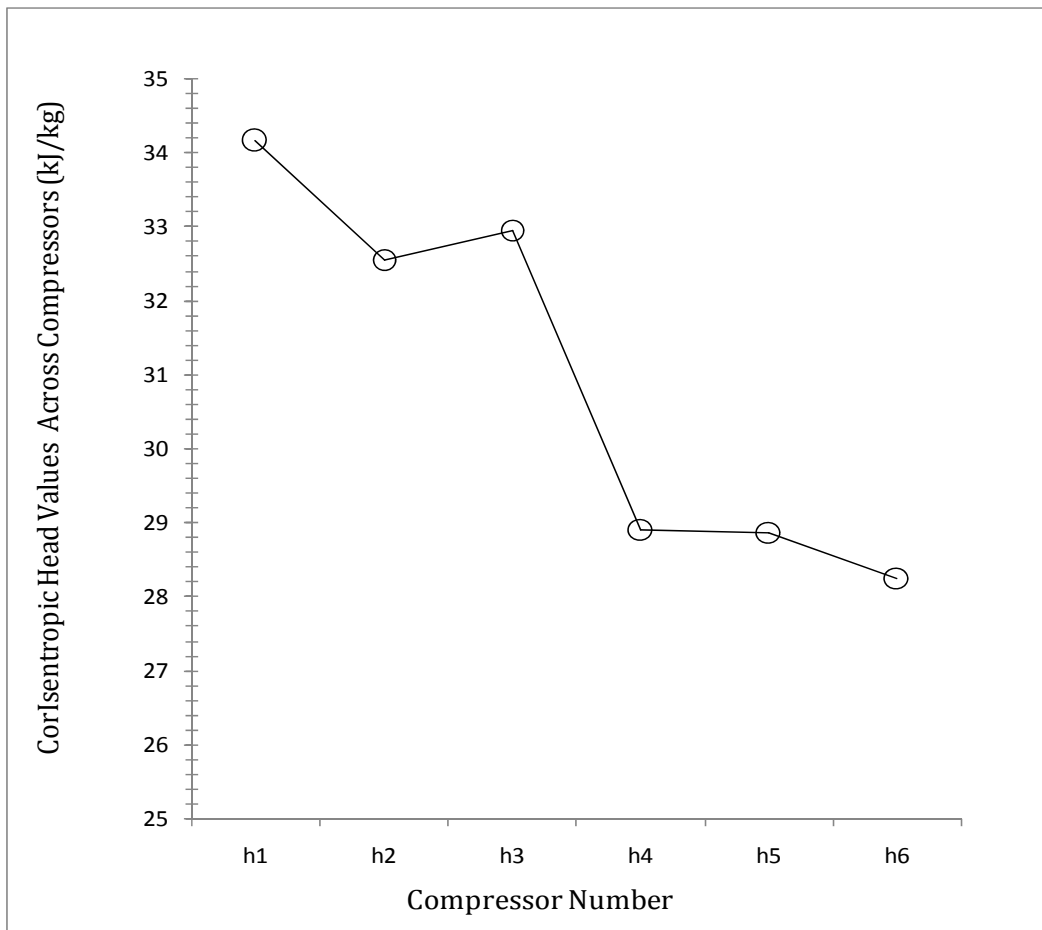

Fig.4.4: Optimum Isentropic Head of Six Compressors obtained using ACO

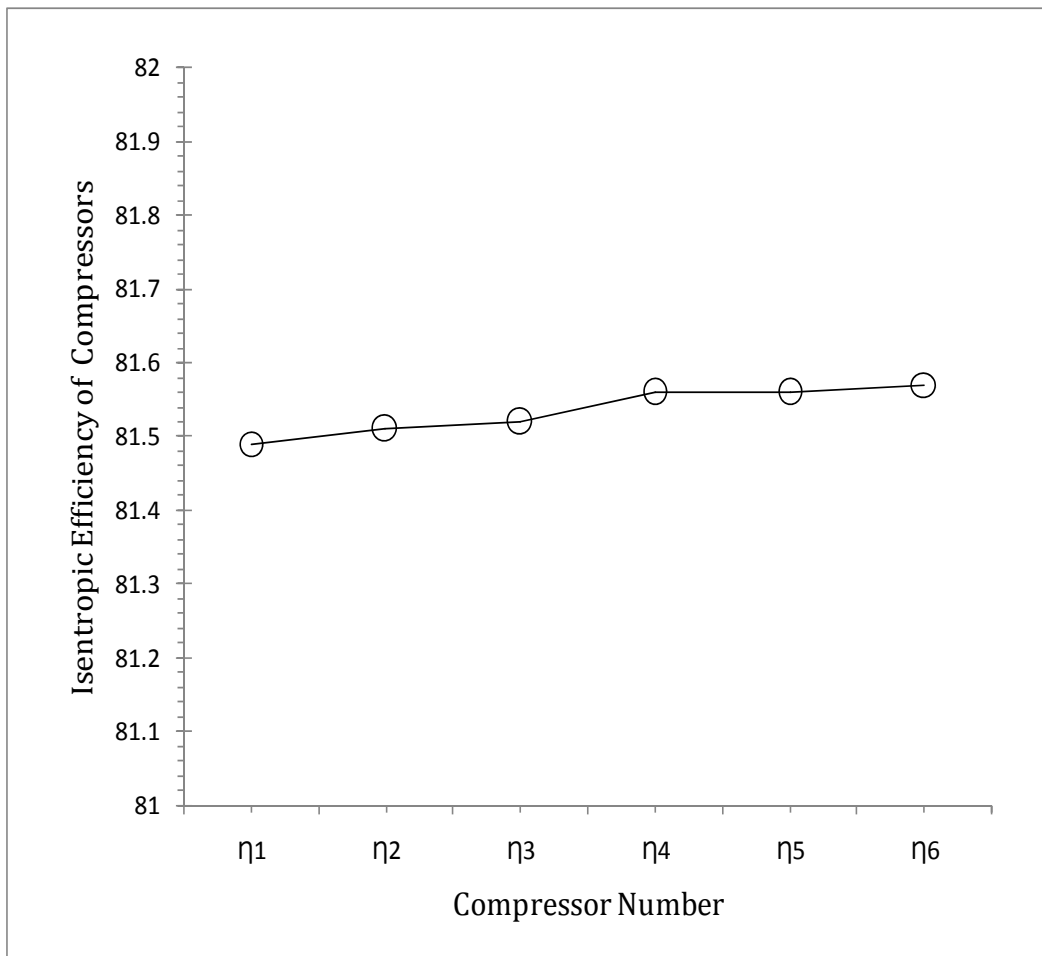

Fig.4.5: Optimum Isentropic Efficiency of Compressors obtained using ACO

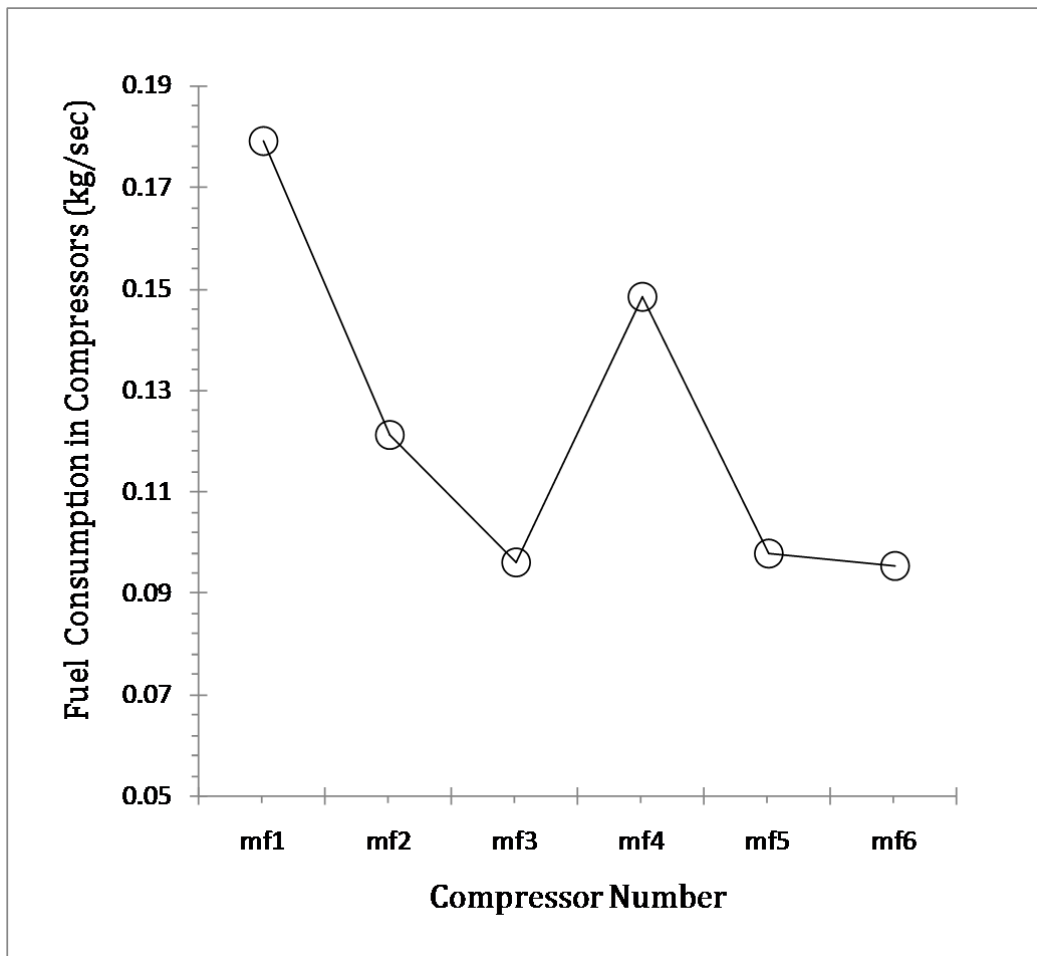

Fig.4.6: Minimum Fuel Consumption in Six Compressors obtained using ACO

4.1.2 Comparison of ACO Results with GRG Results for Minimizing Fuel Consumption in Compressor for Fixed Throughput

Comparison of results obtained using Ant colony Optimization Technique and GRG Technique (Tabkhi, 2007) is presented in Figures 4.7- 4.12.

The pressure at each node is the most important variable as it determines the compressor functioning and hence fuel consumption. The optimal pressures at nodes obtained using Ant Colony Optimization Technique are compared with those obtained by GRG (Tabkhi, 2007) method in Figure 4.7. It is evident from the figure that although the pressure is within bounds, the suction pressure obtained using ACO in all the six compressors is lower than that obtained by using Generalized Gradient Technique. This saves energy in sending the gas to pipeline network. However, the delivery pressure as is evident in Figure 4.7 at the outlet of the second compressor station is higher as obtained using GRG. This adds the advantage of delivering the gas at higher pressure. Also, it is clearly evident from the figure that utilizing both ACO and GRG technique, different values of suction and delivery pressures are obtained in compressors. This must bring variation in fuel consumption in compressors.

Before we compare the fuel consumption, we must compare other aspects of our solution. The first being amount of gas throughput of the pipeline network, which is 150 kg per second. The comparison of our results with GRG (Tabkhi, 2007), as shown in Figure 4.8 clearly indicates that our results comply with the requirement.

The rotational speeds of various compressors are compared in Figure 4.9. The figure clearly indicates that our rotational speeds are higher than that of GRG (Tabkhi, 2007). Our results indicate not only higher rotational speeds, but different rotational speeds for each of the compressors at the station. This must be because the mass flow rate through each of the compressors is different. This result gives a natural heuristic angle to the solution obtained.

The implications of different speeds and different mass flow rates on compressor heads would be interesting to compare, which has been done in Figure 4.10. As anticipated heads are median of the head for GRG solution. Heads of station 1 and those of station 2 are within a close range unlike GRG solution where station station 1 has much higher heads as compared to station 2. Apparently this puts a question mark on the efficiency of the compressors and these have been compared in Figure 4.11 where it is clearly seen that our efficiencies are consistently higher and uniform for all the compressors. Having seen so much of operational improvement, it should come as no surprise that fuel consumption in the current solution is lower than in GRG (Tabkhi, 2007), as seen from Figure 4.12.

In economic terms, this reduction would save 352,076.58 USD per year, assuming the cost of natural gas per kg is 0.74 USD.

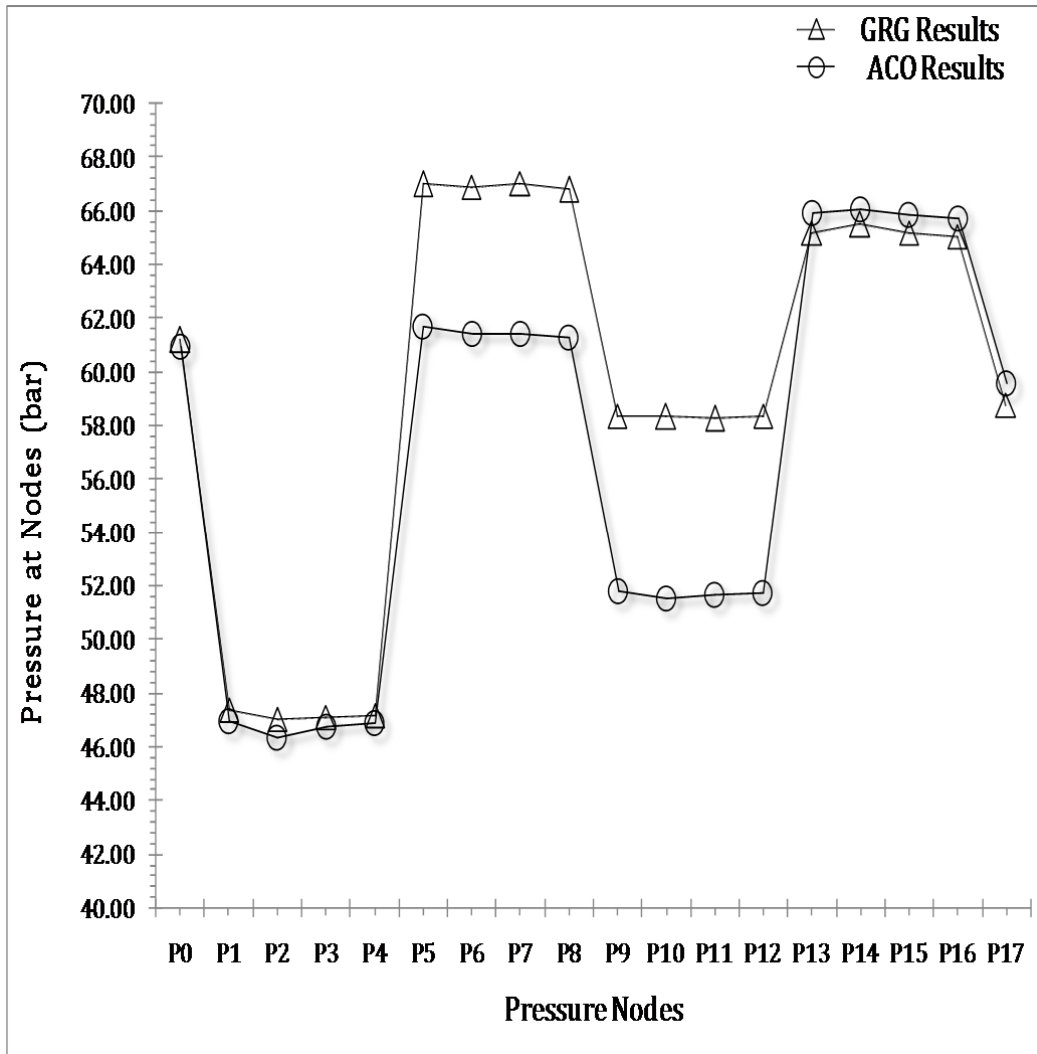

Fig.4.7: Comparison of Optimum Pressure Values at Eighteen Pressure Nodes obtained using (a) GRG and (b) ACO

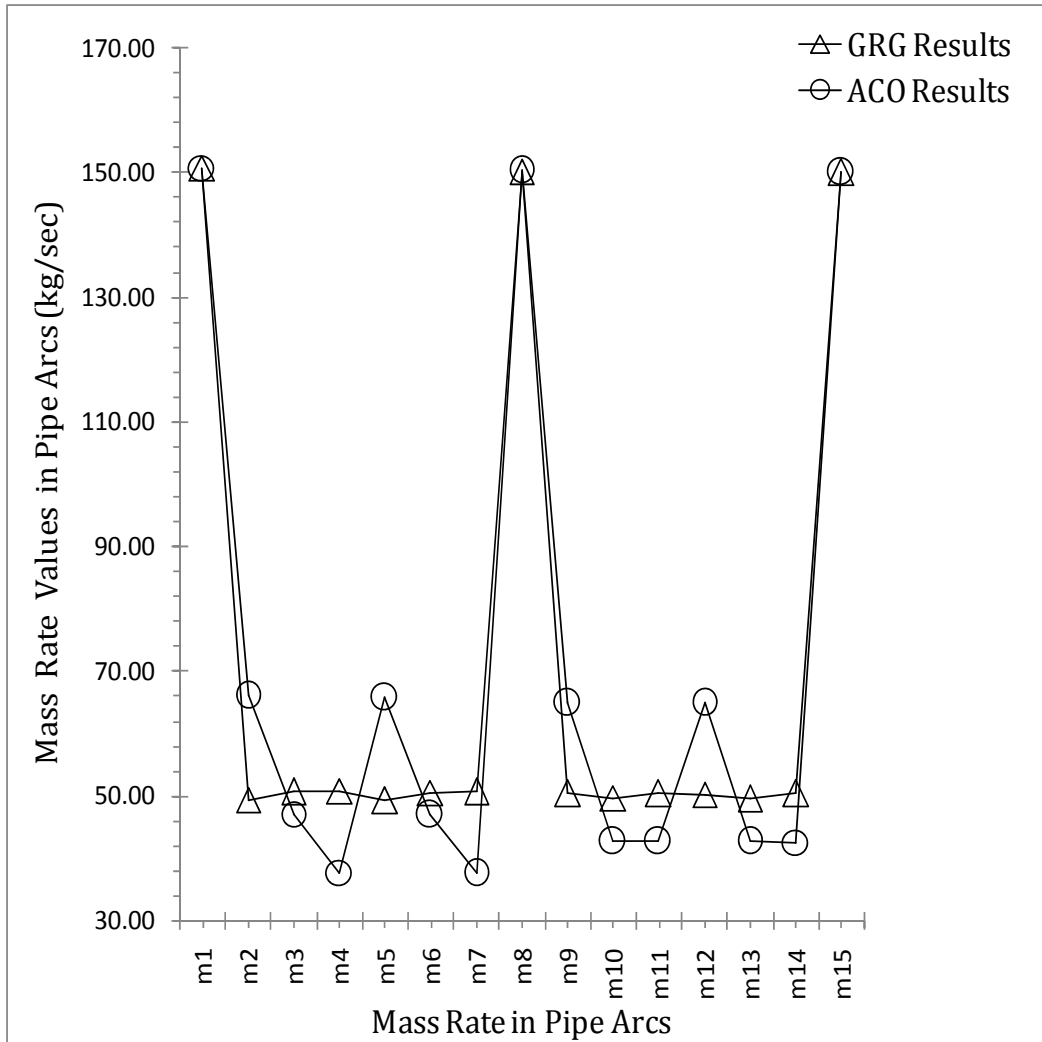

Fig.4.8: Comparison of Optimum Gas Mass Flow Rate in Fifteen Pipe Arcs as obtained using (a) GRG and (b) ACO

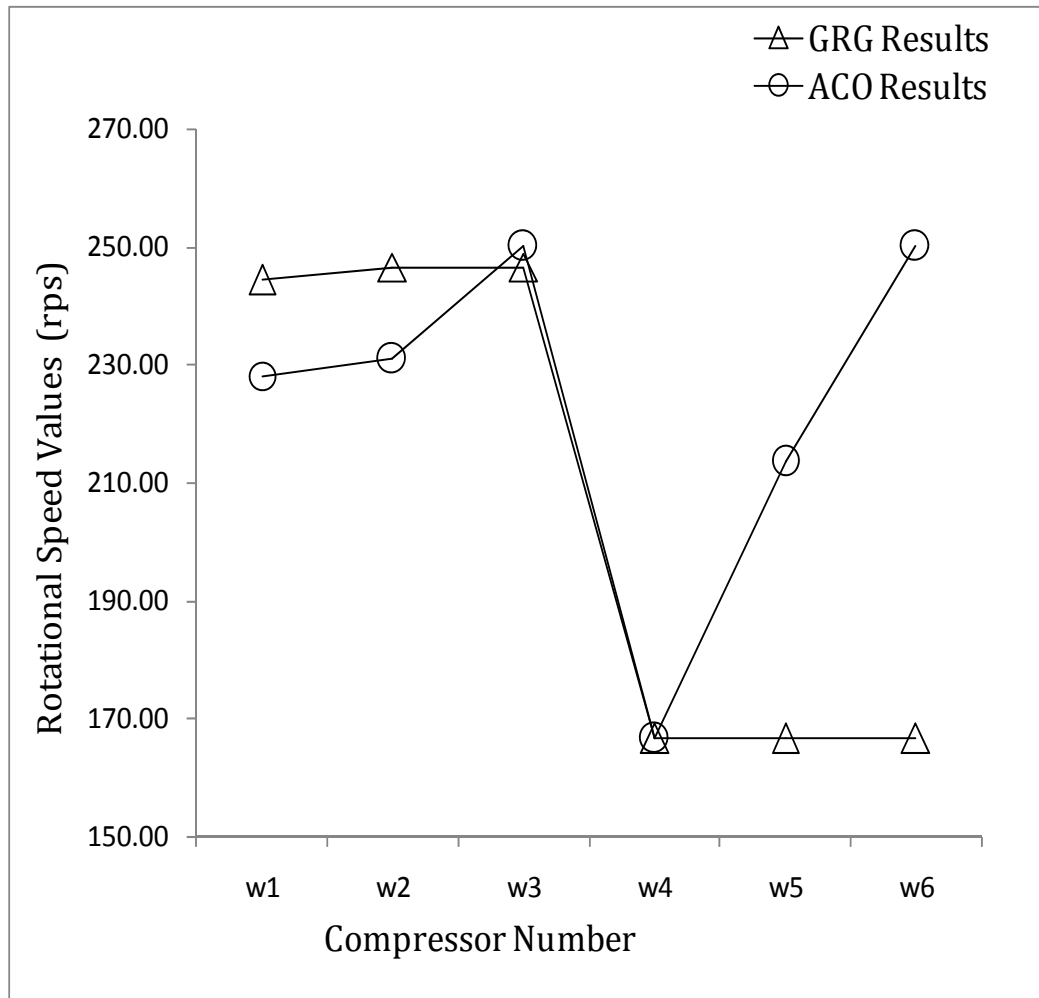

Fig.4.9: Comparison of Optimum Rotational Speed in Six Compressors obtained using (a) GRG and (b) ACO

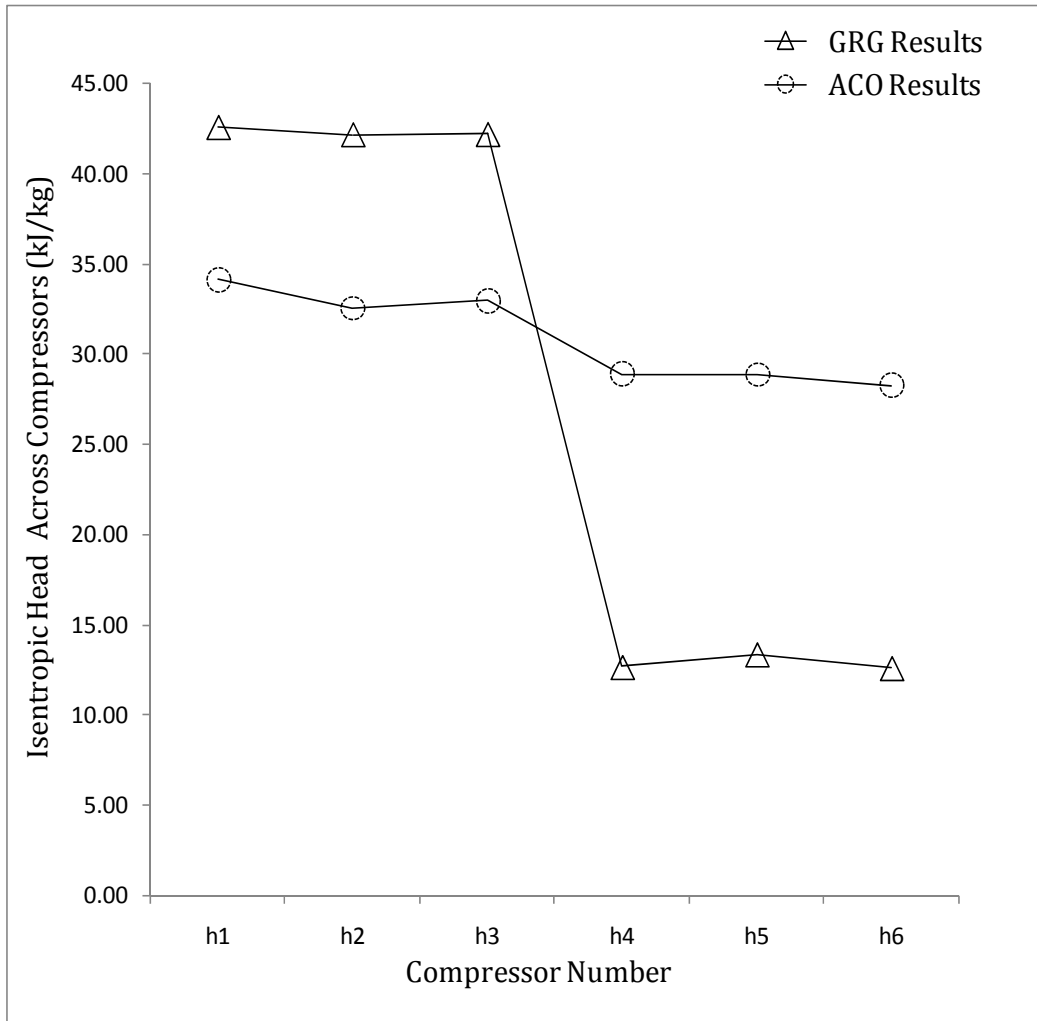

Fig.4.10: Comparison of Isentropic Head of Six Compressors obtained using (a) GRG and (b) ACO

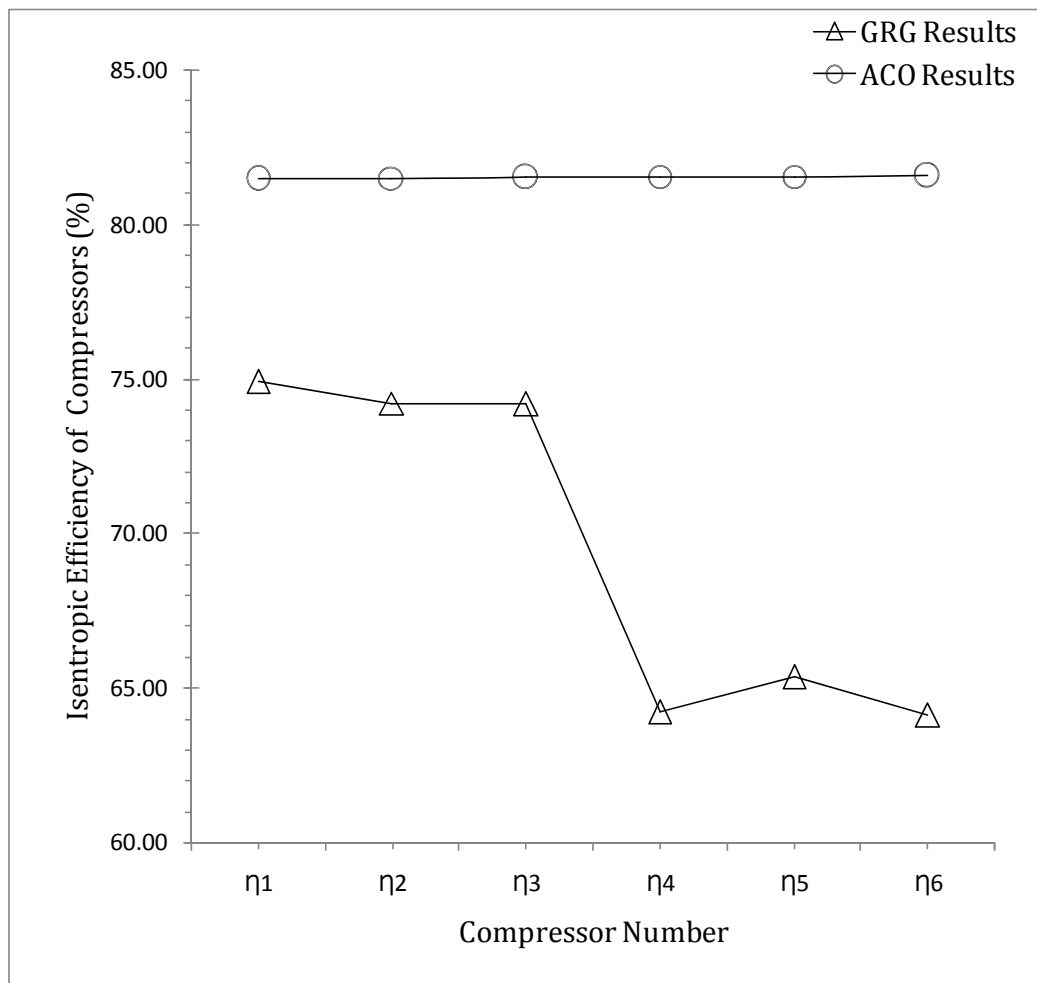

Fig.4.11: Comparison of Optimum Isentropic Efficiency of Six Compressors obtained using (a) GRG and (b) ACO

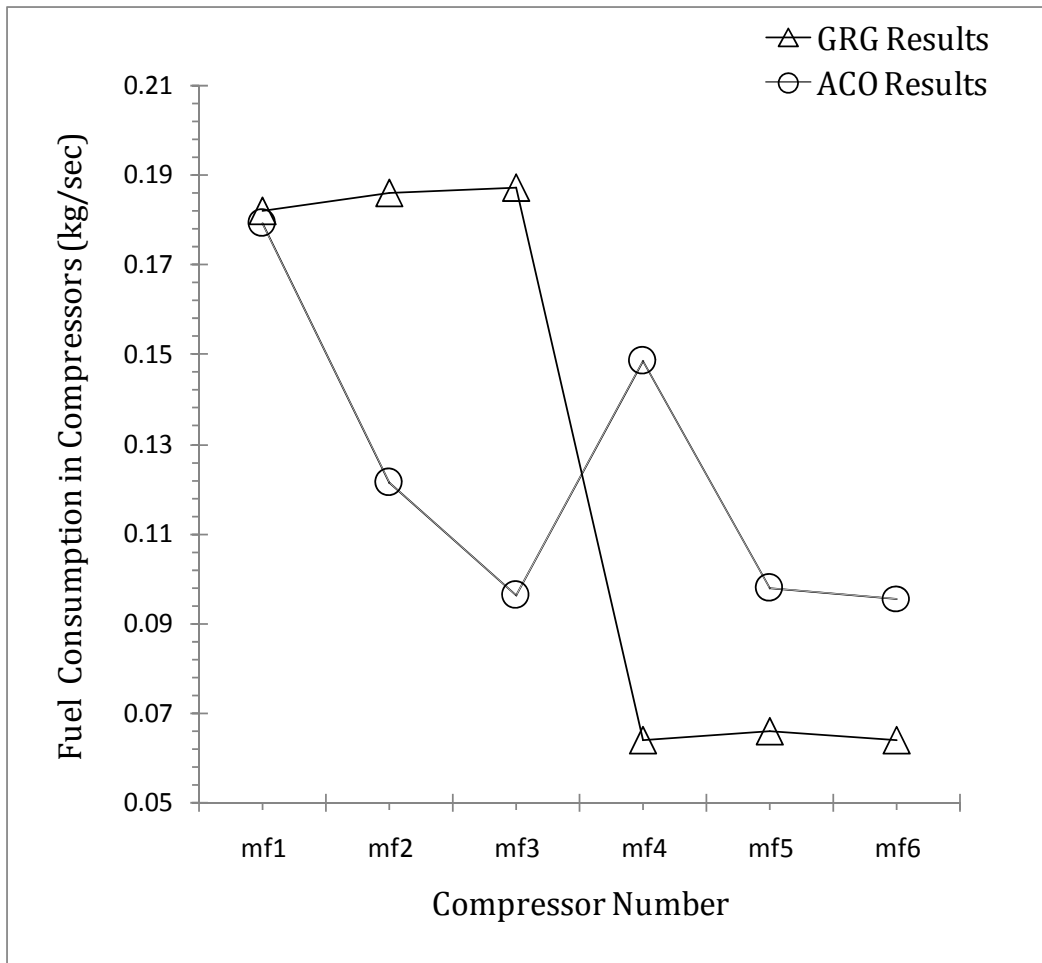

Fig.4.12: Minimum Fuel Consumption in Six Compressors obtained using (a) GRG and (b) ACO

4.2 Multi-Objective Optimization Results

The Multiobjective Ant Colony Algorithm presented in Table 3.11 is used for minimizing fuel consumption and maximizing throughput at the delivery station. The gas pipeline network was shown in Figure 3.3. The evolutionary technique generates a number of solutions from which the best solutions are saved in the solution matrix. Five ants were initially chosen and three best units out of five were selected. In the subsequent iterations which throw up three more solutions are compared with earlier three best solutions and three best out of the six are selected thus improving solutions with subsequent iterations. The technique is based on combining single objective Ant Colony Optimization technique with adaptive weight technique, hence random weights were selected such that the sum of weights remains always equal to unity. Before the Multiobjective Ant Colony optimization technique is applied to gas pipeline network problem, it has been tested for some established test functions (Equation 34a and 34b, 35a and 35b, 36a and 36b).

i. ZDT1 function

Number of variables $n = 4$

$$f_1(x) = x_1; \quad (34a)$$

$$f_2(x) = y * t; \quad (34b)$$

$$y = 1 + \frac{9 * \sum_{i=2}^n x_i}{(n-1)}; \quad t = 1 - \sqrt{\frac{f_1(x)}{y}}; \quad x_i = [0,1], i = 1, \dots, 30$$

ii. ZDT2 function

Number of variables $n = 4$

$$f_1(x) = x_1; \quad (35a)$$

$$f_2(x) = y * \left(1 - \frac{f_1(x)}{y}\right)^2 \quad (35b)$$

Where

$$y = 1 + \frac{9 * \sum_{i=2}^n x_i}{(n-1)};$$

iii. ZDT3 function

Number of variable $n = 4$

$$f_1(x) = x_1; \quad (36a)$$

$$f_2(x) = y * \left(1 - \sqrt{\frac{f_1}{y}} - \left(\frac{f_1}{y}\right) * \sin(10\pi f_1)\right) \quad (36b)$$

$$y = 1 + \frac{9 * \sum_{i=2}^n x_i}{(n-1)};$$

The result of test functions obtained using established multiobjective algorithms taken from literature (Deb, 2010) is compared with those obtained using Multiobjective Ant Colony Algorithm. These have been shown in figures 4.13, 4.14 and 4.15.

4.2.1 Comparison of Standard Test Problems (ZDT1, ZDT2 and ZDT3) Results and Ant Colony Results for validating Ant Colony Optimization Technique.

In section 4.2 three test functions were chosen for validating Ant Colony Optimization technique. The Pareto Front of these three test functions obtained using Multiobjective Ant Colony technique is shown in the figures 4.13a, 4.14a and 4.15a. These Pareto fronts have now been compared to the true Pareto fronts shown in figures 4.13b, 4.14b and 4.15b. It can be clearly seen in the figures that the Pareto plots obtained using Multiobjective Ant Colony Optimization technique are very similar to that obtained using standard Multiobjective techniques. This verifies the utility and correctness of developed technique.

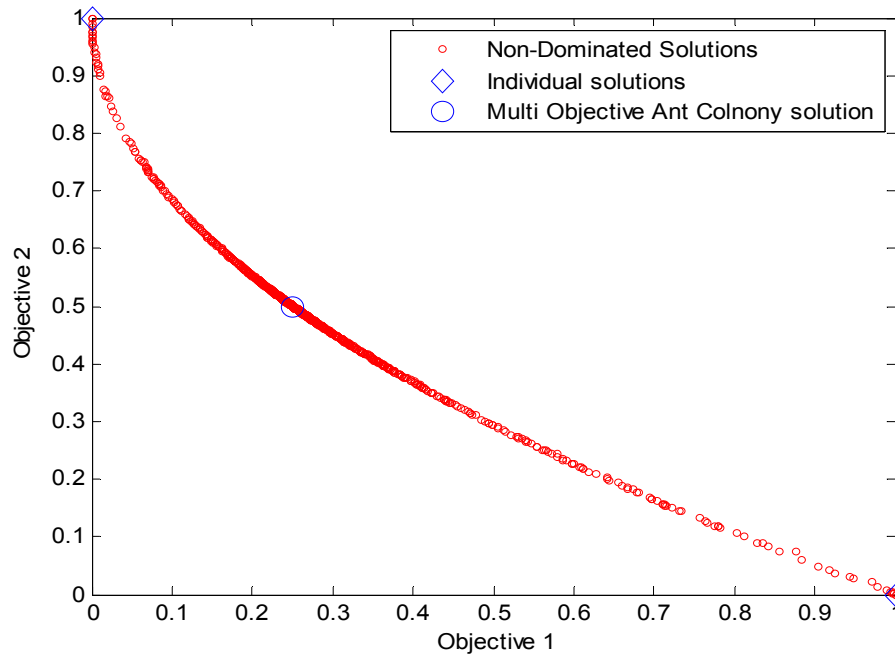

(a)

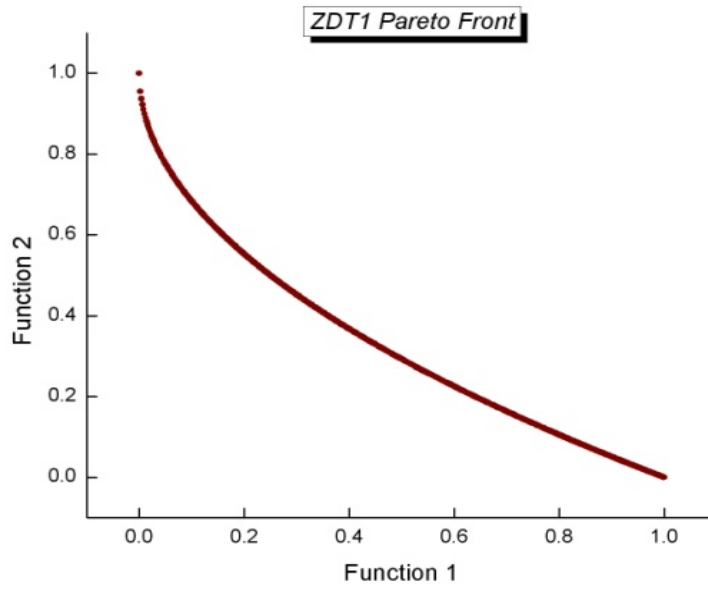

(b)

Fig. 4.13: Pareto Front of ZDT1 (a) obtained using Multiobjective Ant Colony Optimization (b) True Pareto front.

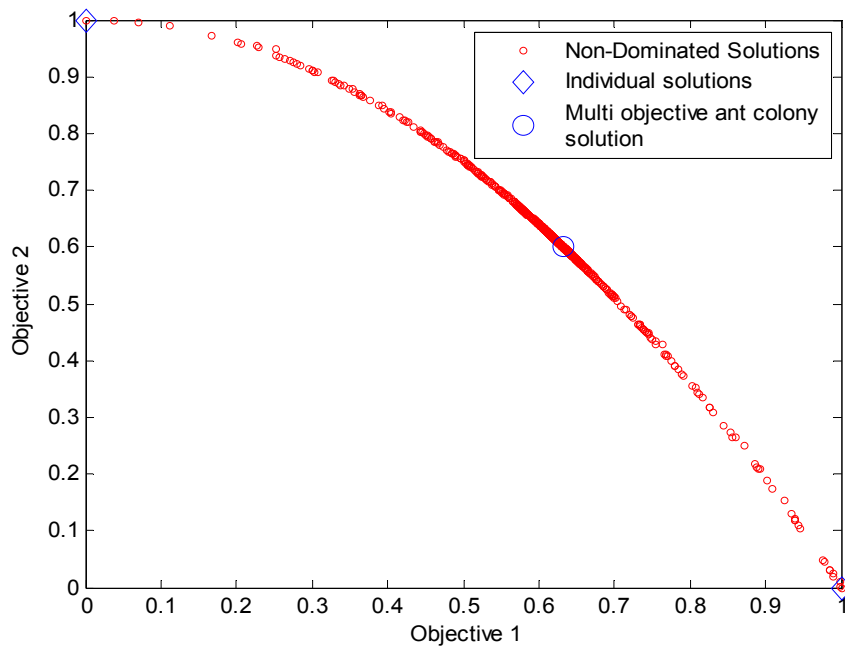

(a)

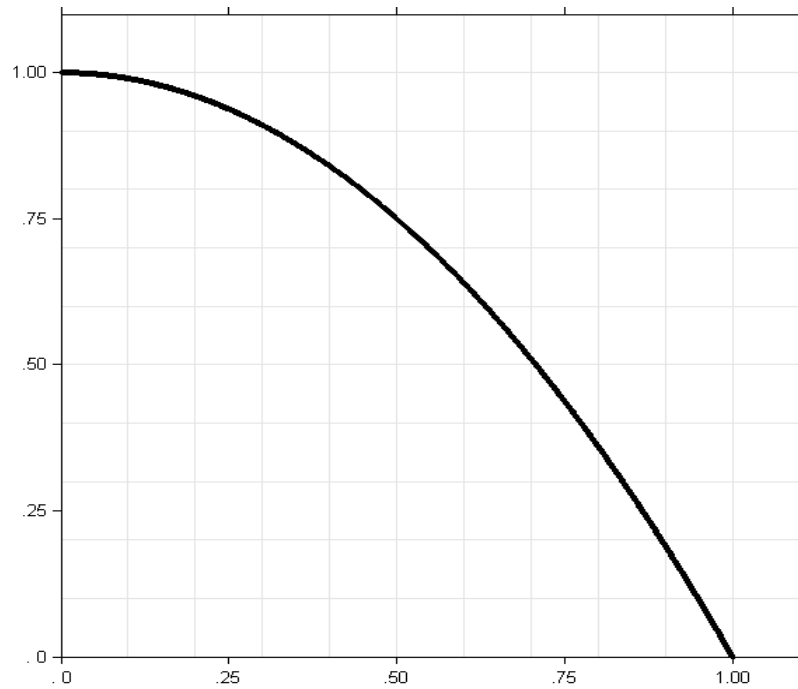

(b)

Fig. 4.14: Pareto Front of ZDT2 (a) obtained using Multiobjective Ant

Colony Optimization (b) True Pareto front.

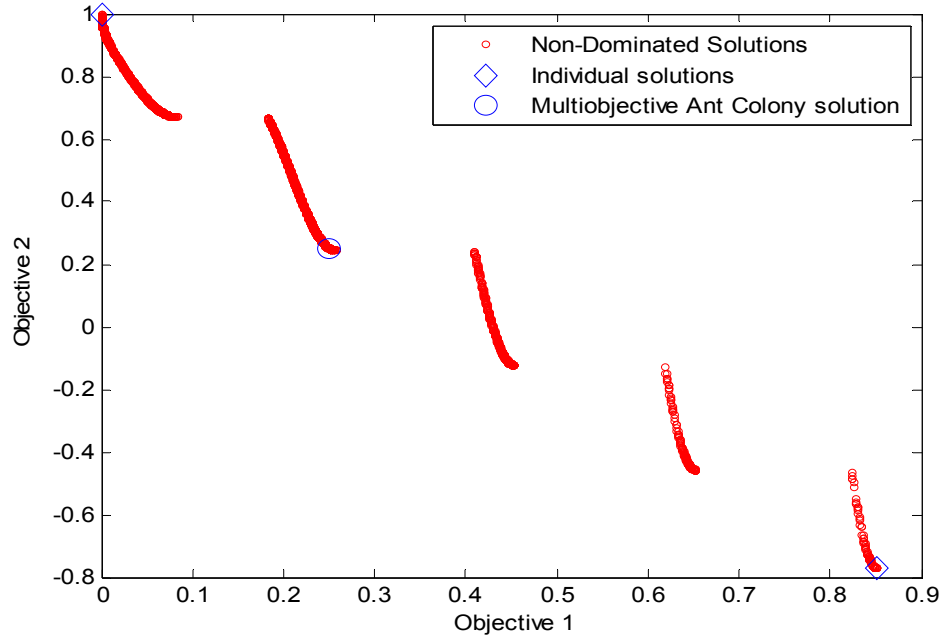

(a)

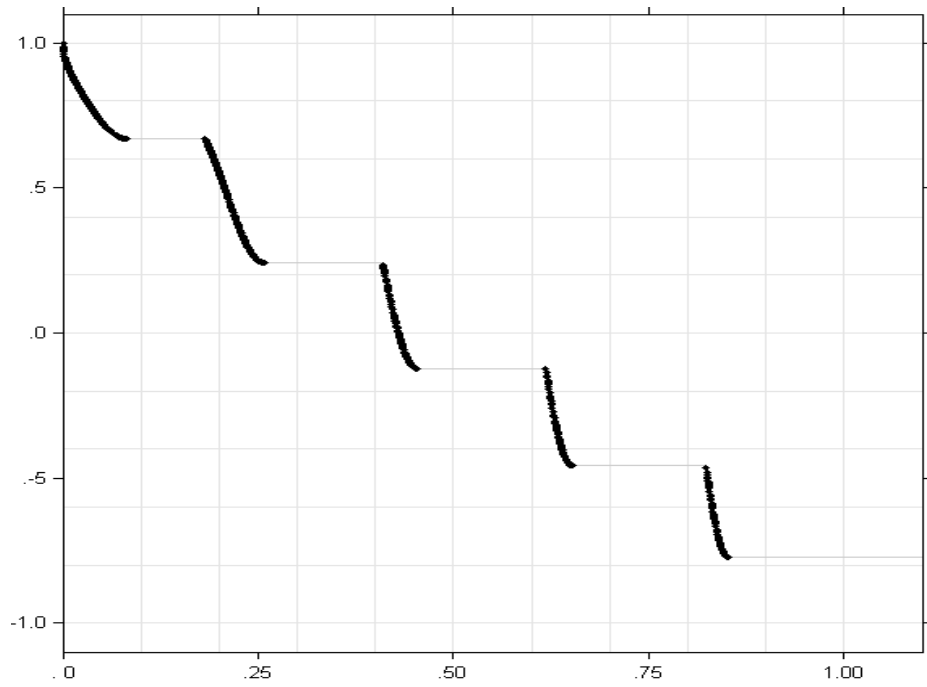

(b)

Fig. 4.15: Pareto Front of ZDT3 (a) obtained using Multiobjective Ant Colony Optimization (b) True Pareto front.

4.2.2 Multi-Objective Ant Colony Results for Minimizing Fuel Consumption and Maximizing Throughput

In section 4.2.1 Multiobjective Ant Colony Optimization Technique was validated using the results of standard Pareto Fronts. The technique is now used for optimizing a Single Gas Source and Single Delivery Pipeline Network System shown in Figure 3.3. The objective chosen is to minimize fuel consumption in compressors and maximize throughput at the delivery station. The Pareto front obtained by setting different weight (0-1.0) have been shown in Figure 4.16. The x axis plots fuel consumption and y axis plots throughput at the delivery station. The interaction among different objectives gives rise to a set of compromised Pareto optimal solutions. Each solution on the Pareto optimal curve obtained in Figures 4.16 for different weights is not dominated by other solution. It is clearly evident from the Pareto Fronts that in going from one solution to another, it is not possible to improve on one objective without making the other objective worse.

The multi-objective approach on gas pipeline network makes possible to generate several solutions from which the most appropriate one can be chosen based on additional analysis such as involvement of operator to improve the acceptance of system by managers and practitioners.

Comparison of the Pareto front of different weights reveals one more crucial

information, i.e. the solution obtained does not preserve one's initial preferences of choosing weights no matter how the weights were set. The solution obtained by combining the multiple objective functions to a single objective function depends on the relative magnitude of the objective functions. When setting the weights for combining the objectives, only the relative importance of the objectives should be considered, not the relative magnitude of the function values. This very useful idea has been often overlooked in most of the literature available.

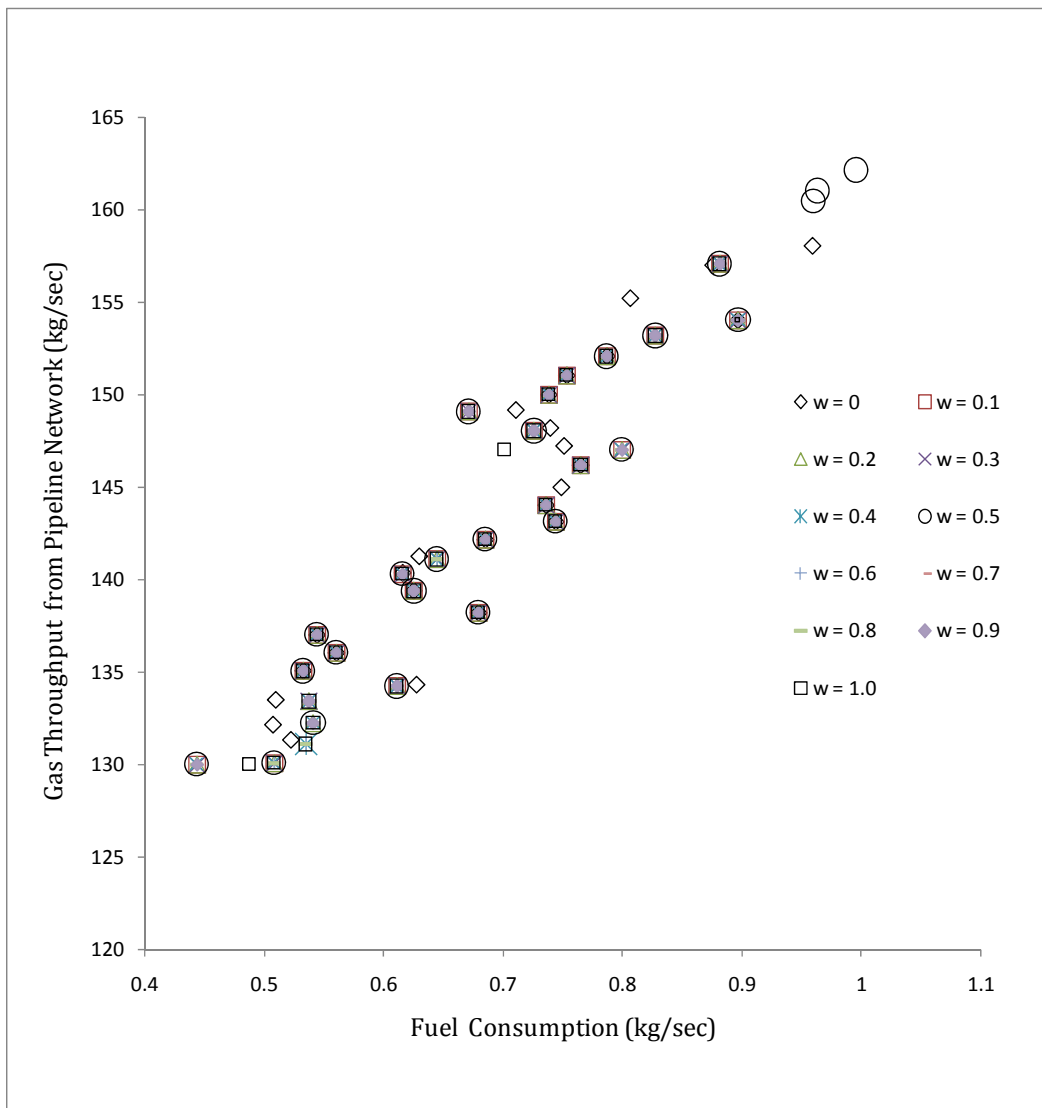

Fig. 4.16: Pareto Front of Single Supply, Single Delivery Gas Pipeline Network

System for Different Weights obtained using Multiobjective Ant Colony Optimization Technique

4.3 Conclusion of Chapter

Chapter 4 presented the optimal results of Single Source Single delivery Gas pipeline network. Single Objective Ant Colony optimization technique was utilized to minimize the fuel consumption in compressors for a fixed throughput. Further the technique was combined with Adaptive weighted sum method to solve a set of test functions. The true Pareto front was compared with that obtained by using Ant Colony Optimization technique. The similarity of the Pareto front obtained validates the technique. The technique was further applied to the Multiobjective problem of minimizing fuel consumption in compressors and maximizing throughput at the delivery station.

Chapter 5 presents the results of minimizing the fuel consumption at the seven compressors for a fixed value of throughput at the nineteen delivery stations.

Chapter 6 gives the conclusions and perspectives for future works.

CHAPTER 5

MULTI – SOURCE - MULTI - DELIVERY PIPELINE NETWORK OPTIMIZATION - RESULTS

In this chapter optimization results of Multi-Source, Multi-Delivery Gas Pipeline Network using Ant Colony Optimization Technique is presented. To facilitate the reading Figure 3.4 is reproduced once again. The general mathematical formulation of gas pipeline network presented in chapter 3 is used for optimization. The results of minimizing fuel consumption (Equation 3.39) using Ant Colony Optimization Technique are presented.

5.1 Ant Colony Results for Minimizing Fuel Consumption in Compressors for Fixed Throughput

The evolutionary method generates a number of solutions from which the best solutions are saved in the solution matrix. The Ant Colony Evolutionary technique generates a number of solutions from which the best solutions are saved in the solution matrix. Five ants were initially chosen and three best ants out of five were selected. In the subsequent iterations which throw up three more solutions are compared with earlier three best solutions and three best out of the six are selected thus improving solutions with subsequent iterations. The results obtained using Ant Colony Optimization technique has been presented in Figures 5.1 to 5.6.

The pressure values obtained at distinct nodes using Ant Colony Optimization are shown in Figure 5.1. Lower and upper limits of pressure on different nodes were shown in Table 3.6. which is also plotted in Figure 5.1. It can be clearly seen that

pressure at all

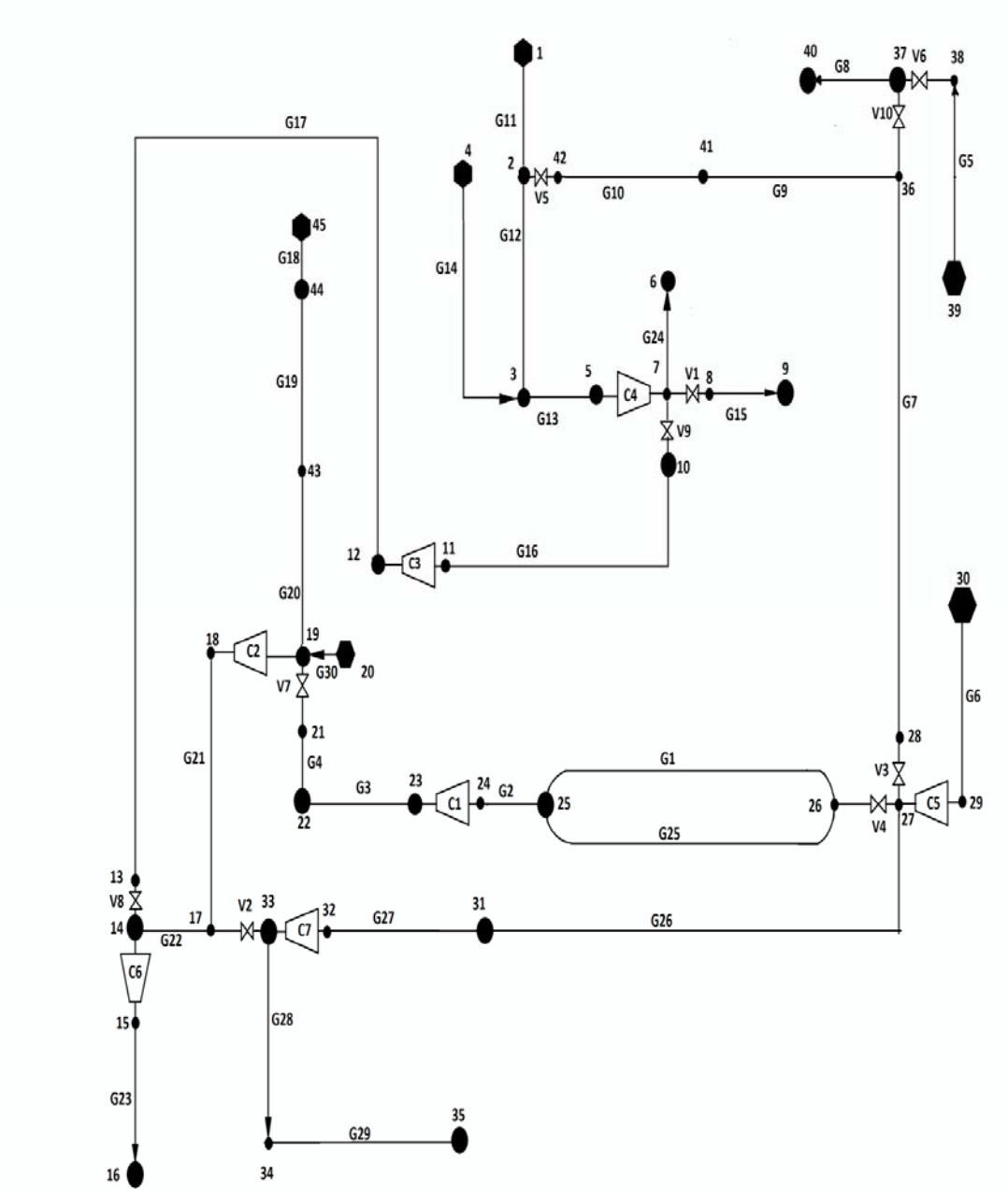

Fig. 3.3 Multi-Source, Multi- Delivery Pipeline Network System

the nodes obtained from Ant Colony Optimization are well within the pressure limits. Also from Table 3.6 it can be seen that the required delivery pressure as fixed by the consumer at node 39 was 85 bars. Our pressure obtained from Ant Colony Optimization at node 39 is also 85 bars. This assures the consumer to receive the gas at his desired pressure.

Pressure values in thirty distinct pipeline arcs as obtained using Ant Colony Optimization Technique are shown in Figure 5.2. The maximum operating pressure values shown in Table 3.5 are also presented in the figure. A comparison between the pressure in pipe arc obtained using Ant colony Technique and maximum allowable pressure has been presented. It can be clearly seen that the pressure values in pipe arc always remain below the maximum allowable operating pressure.

Optimized mass rate values in the thirty pipe arc network as obtained using Ant Colony are shown in Figure 5.3. The output mass rate value at the outlet of compressor is used to calculate the fuel consumption in the compressors.

Optimum gas supply required from the six source station to satisfy the gas demand at the nineteen delivery station using Ant Colony Optimization technique are shown in Figure 5.4. The maximum gas that can be supplied from the source station were presented in Table 3.7. It can be well seen from the figures that the supply rate obtained from Ant Colony Technique always remains below the maximum value.

Optimized gas flow rate values in pipe arcs obtained from Ant Colony Optimization techniques are represented in Figure 5.5. Comparison between the maximum rate

through valves and optimized values obtained from the Ant Colony Optimization technique show that the values obtained using ACO are always below the maximum value. This ensures that the network is operating under safe operating conditions.

Finally the Fuel Consumption in compressors is depicted in Figure 5.6. In the figure the results have been presented when only compressor 4 and 5 are working and others have been switched off. Similar calculations can be done with any number of compressors working and the rest switched off.

However, in this case only compressor 4 and 5 are sufficient to deliver the gas at the required rate. This has ensured that all the working compressors are at their peak efficiency.

Figure 5.1 Optimum Pressure Values at Forty Five Pipe Nodes obtained using ACO

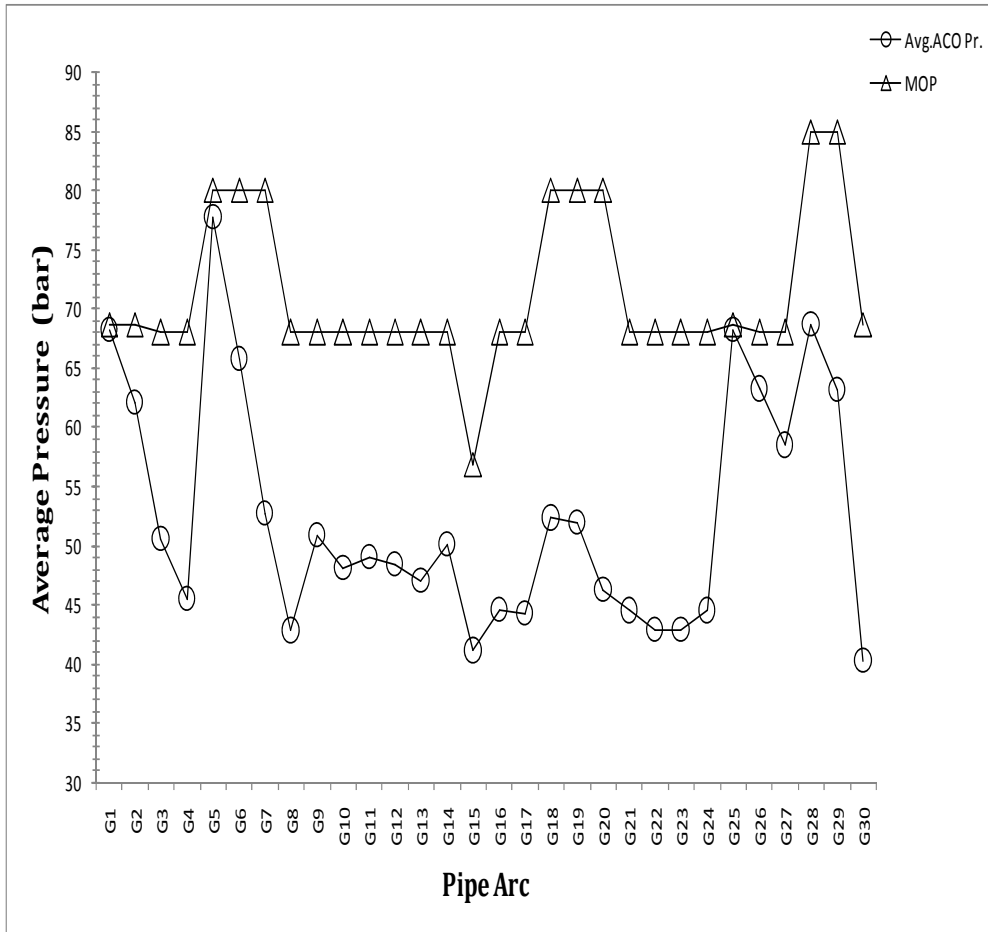

Figure 5.2 Comparison of MOP and Average Pressure in Thirty Pipe Arc obtained using ACO

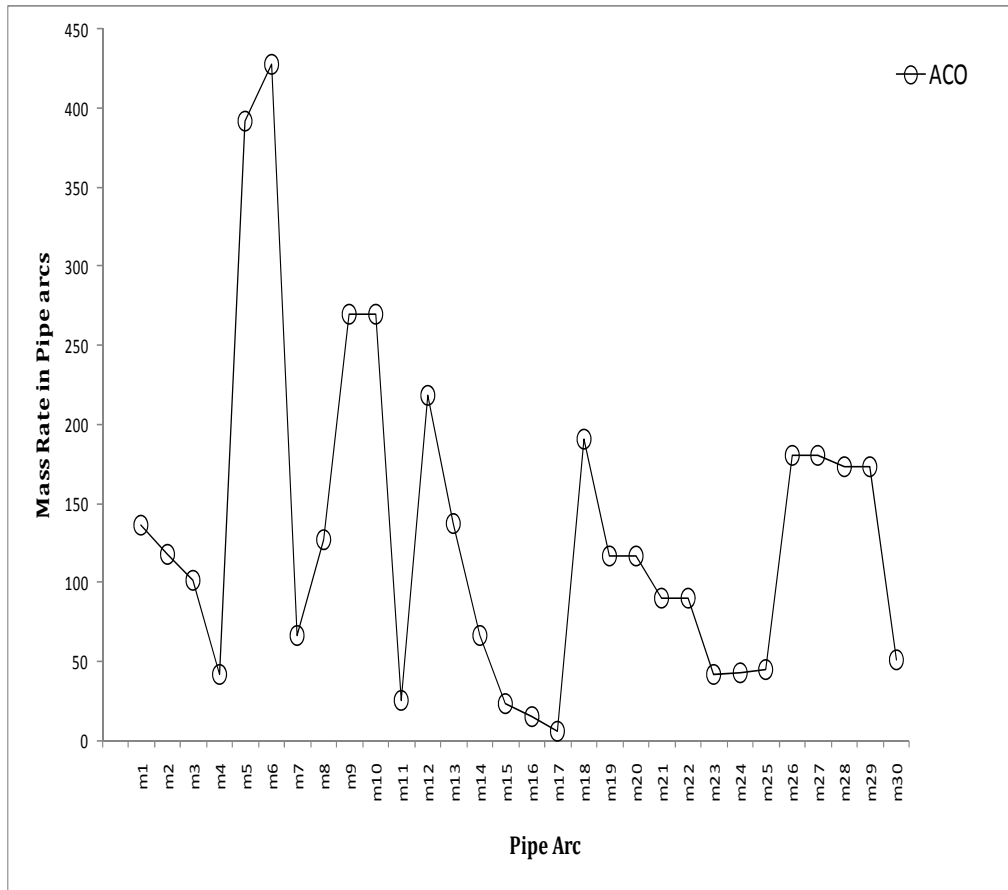

Figure 5.3 Optimized Gas Mass Rate in Thirty Pipe Arcs obtained using ACO

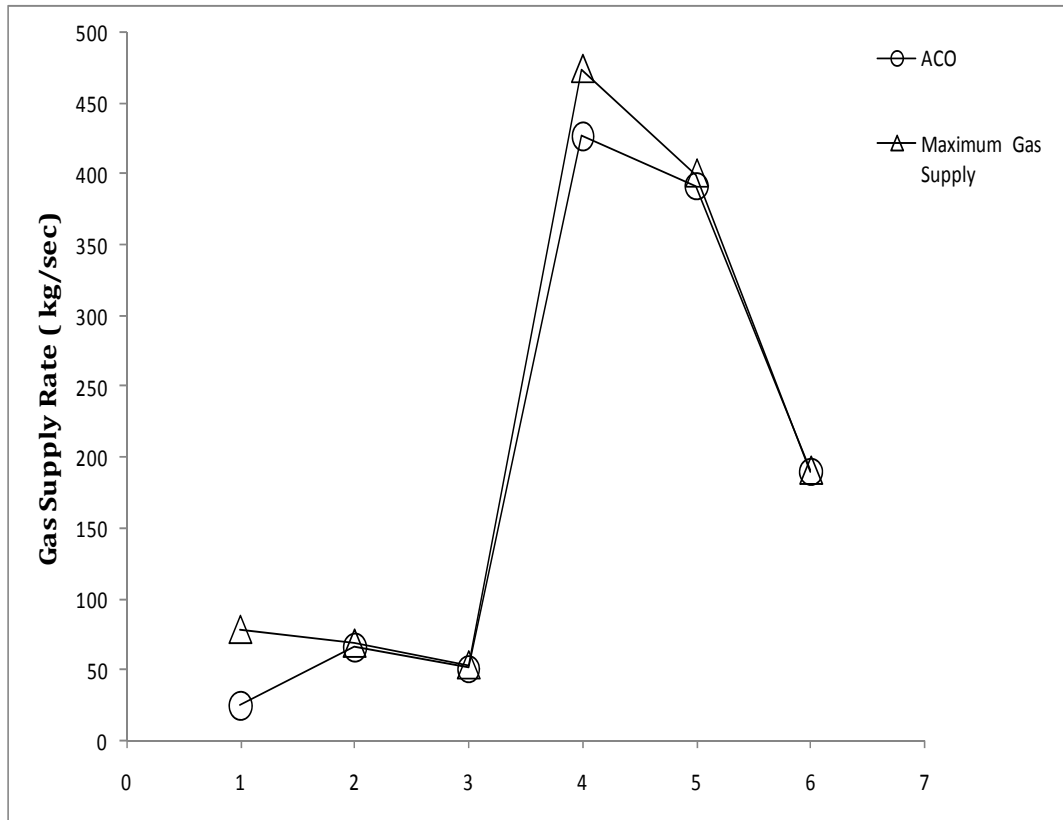

Figure 5.4 Comparison of Maximum Gas supply and Gas Supply obtained using ACO at Six Gas Source Stations

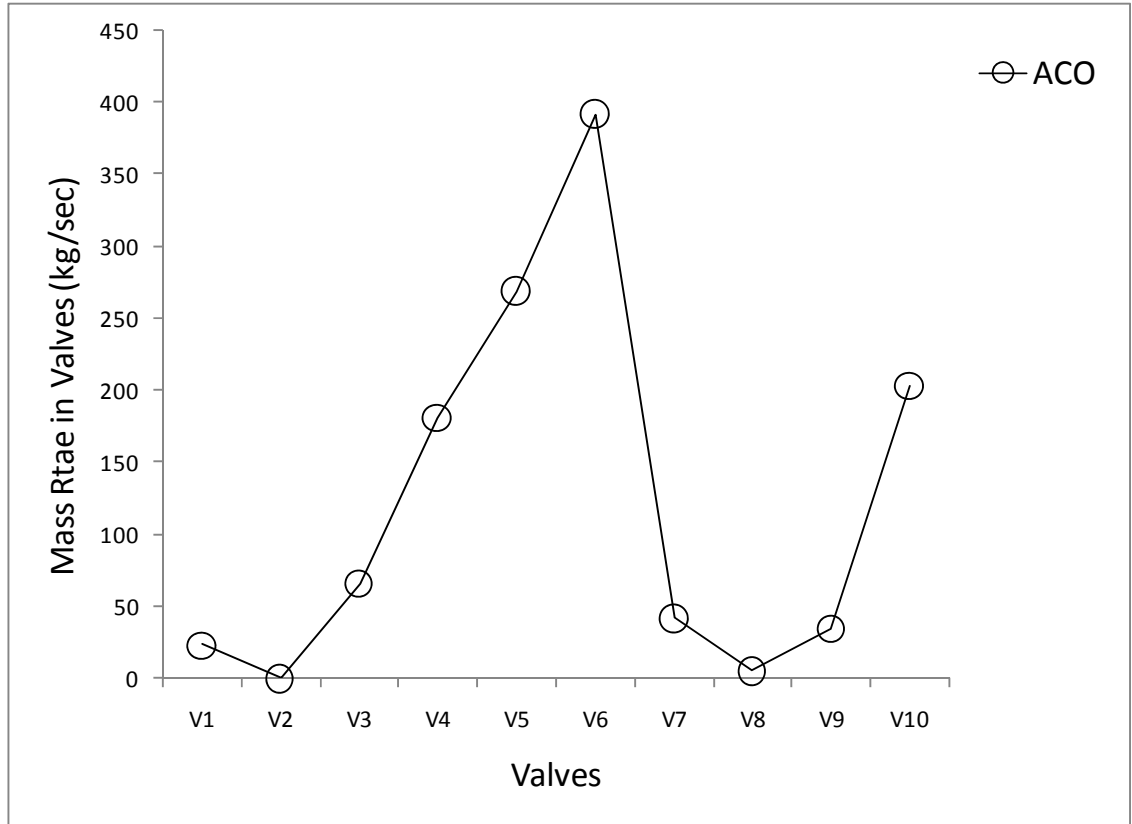
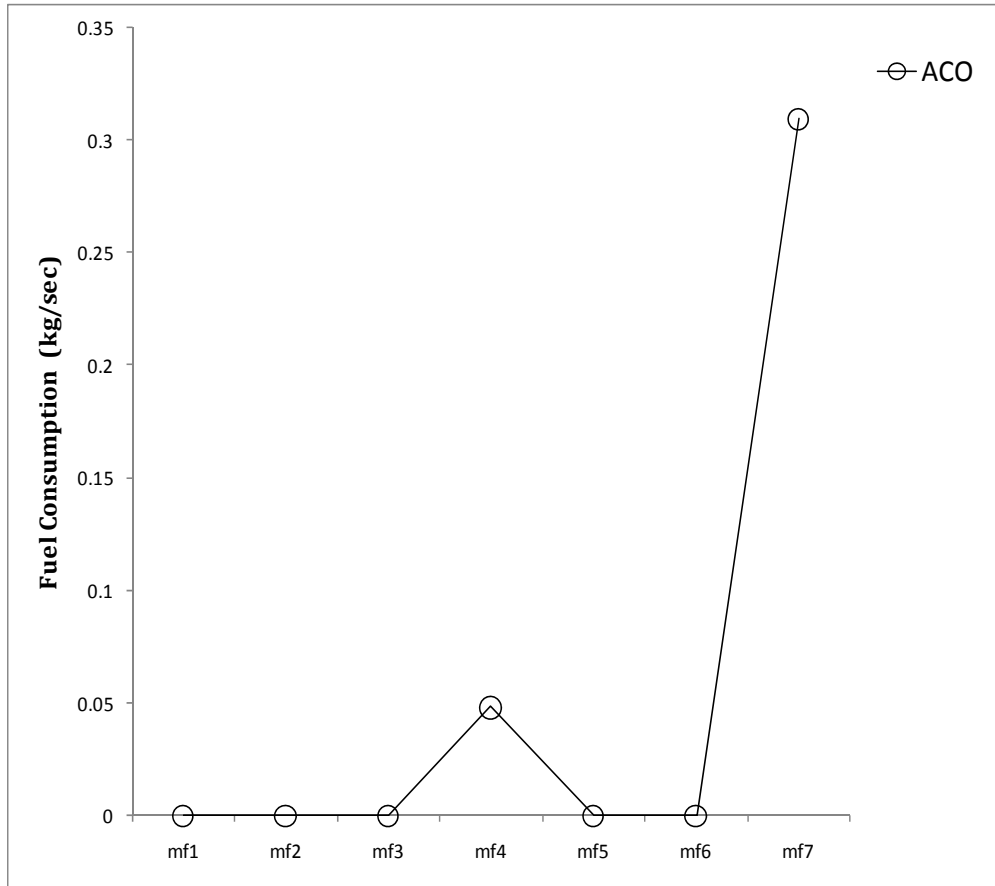

Figure 5.5: Optimum Gas Mass Rate Values through Ten Valves obtained using ACO



**Figure 5.6 Fuel Consumption at Seven Compressors
obtained using ACO**

Figure 5.1 Optimum Pressure Values at Forty Five Pipe Nodes obtained using ACO

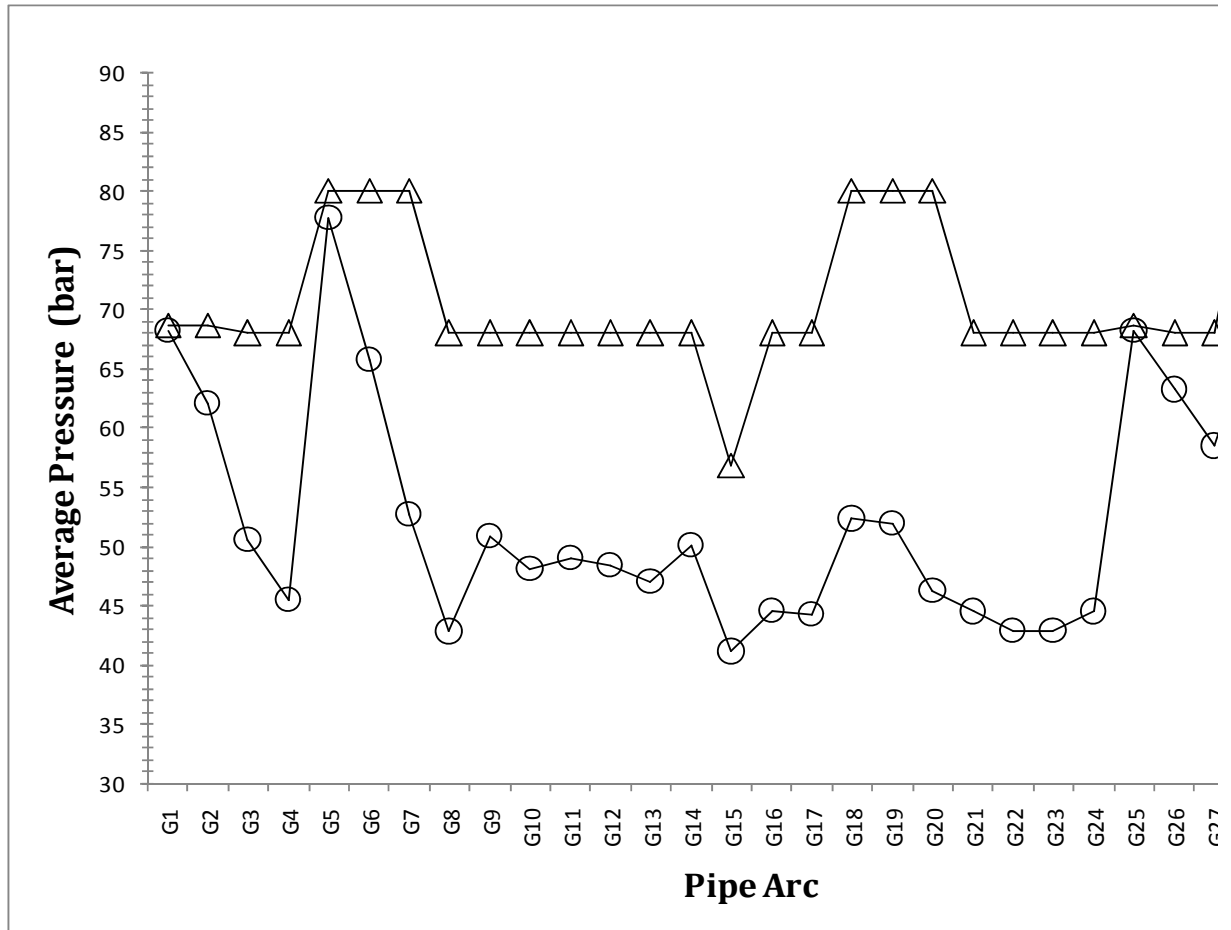

Figure 5.2 Comparison of MOP and Average Pressure in Thirty Pipe Arc obtained using ACO

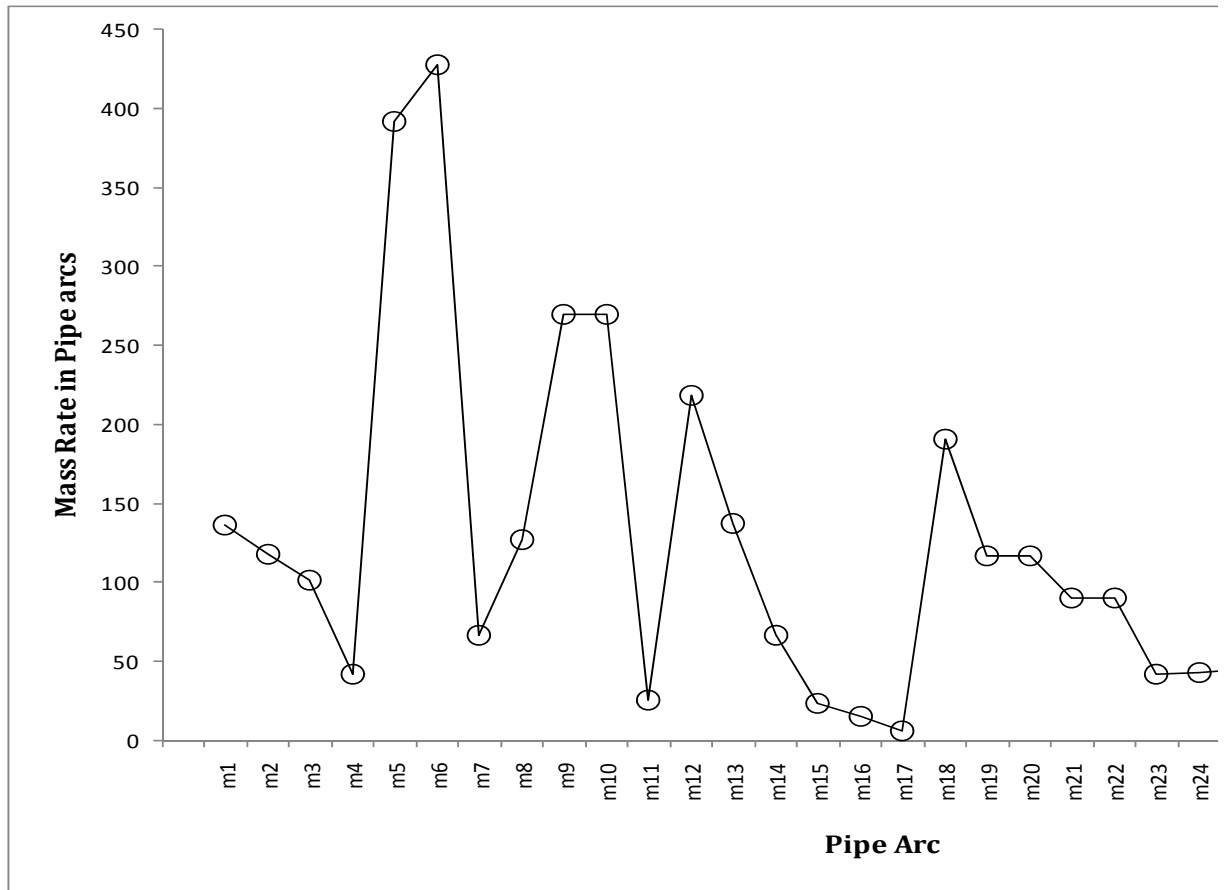

Figure 5.3 Optimized Gas Mass Rate in Thirty Pipe Arcs obtained using ACO

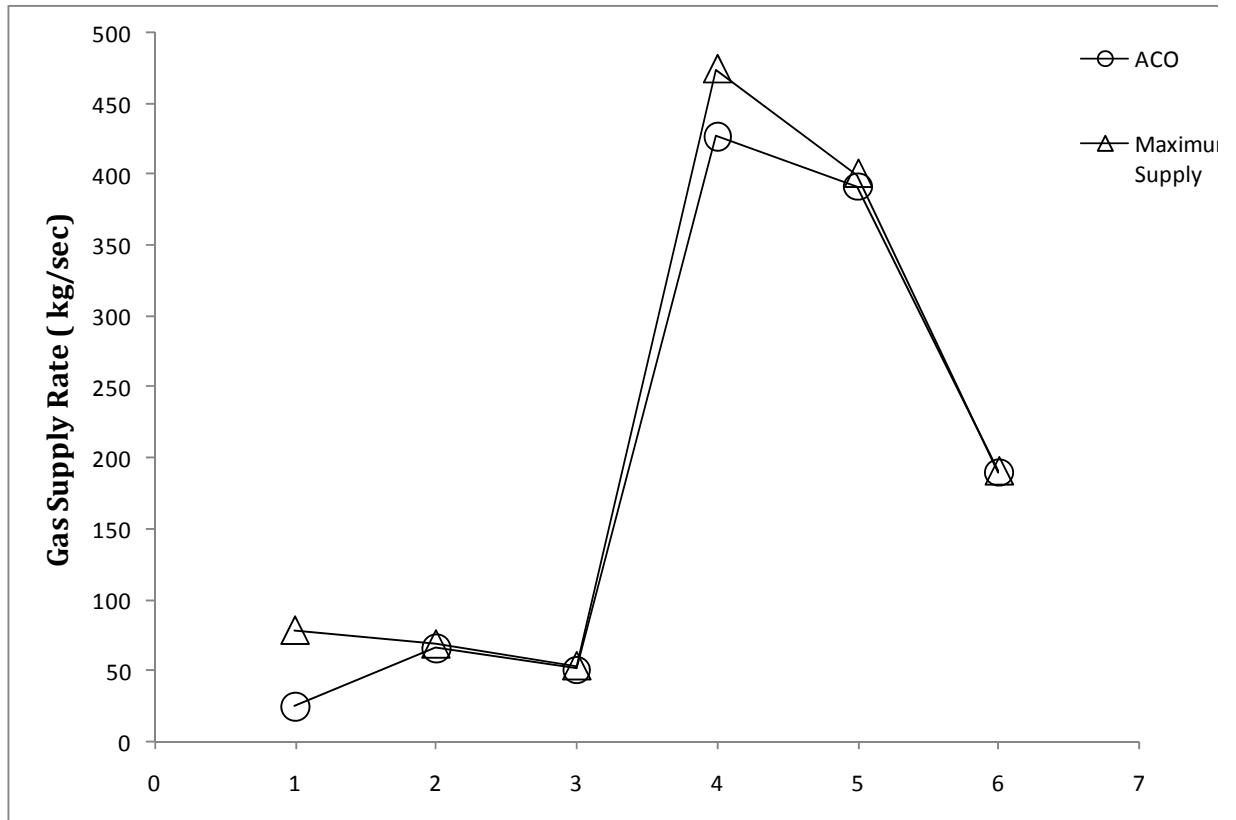

Figure 5.4 Comparison of Maximum Gas supply and Gas Supply obtained using ACO at Six Gas Source Stations

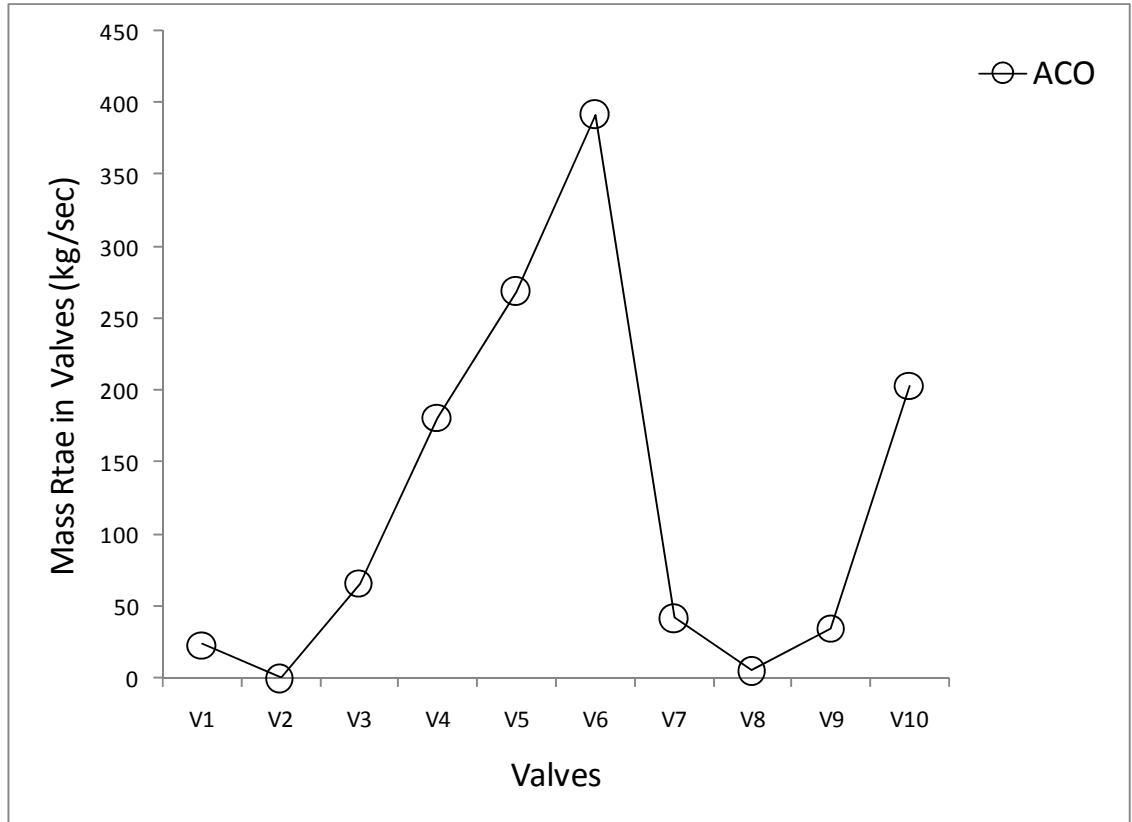

Figure 5.5: Optimum Gas Mass Rate Values through Ten Valves obtained using ACO

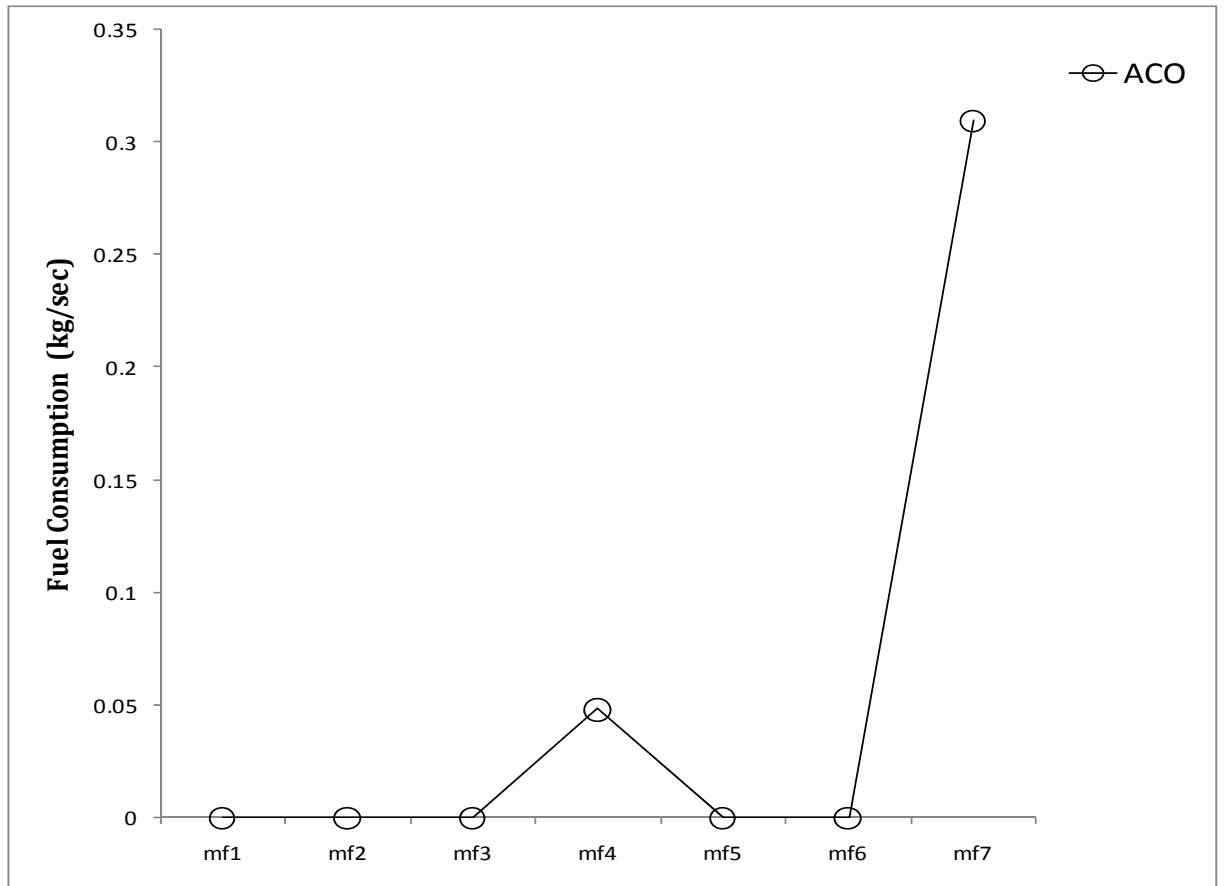

Figure 5.6 Fuel Consumption at Seven Compressors obtained using ACO

CHAPTER 6

CONCLUSION AND PERSPECTIVES

The objective of the PhD thesis was to develop a general methodology for gas transmission pipeline network model based on an optimization- oriented framework. The mathematical model and optimization technique for gas pipeline network proposed in the study shows that the efficient operation of compressor station is of extreme importance for enhancing the performance of gas pipeline network. For optimization, various deterministic techniques have been used in the past. But now due to the drawback of these techniques, stochastic techniques like Simulated Annealing, Particle Swarm Optimization, Genetic Algorithm and Ant Colony are becoming popular. However, the application of Ant Colony Optimization technique for optimizing gas pipeline operations has been rare. Apart from these issues, there has been very little work on multiobjective optimization of gas pipeline networks. There has been no application of the Ant Colony Technique for solving multiobjective problem of gas pipeline transportation. Only a few works utilizing Ant Colony have been reported (mentioned in literature review) that too with single objective optimization.

In these contexts, the thesis addressed the following key points:

- i. Developed a general methodology that serves as a modelling core, on which optimization technique was implemented.
- ii. Developed Single and Multiobjective Ant Colony Algorithm that can be utilized to optimize the gas pipeline network.

- iii. Developed Single Objective Ant Colony Optimization technique was implemented to a Single Source, Single Delivery Gas Pipeline Transportation problem.
- iv. Developed Multiobjective Ant Colony Optimization technique was implemented to a Multiobjective problem of Single Source, Single Delivery Gas Pipeline Network System.
- v. To enhance the application of Single Objective Ant Colony Optimization technique, it was applied to a highly meshed complex Multi- Supply, Multi-Delivery Gas Pipeline Network system.

The above mentioned technique has been used to analyze two gas pipeline networks presented in section 6.1.

6.1 Gas Pipeline Network Analysis

The two natural gas pipeline transportation networks chosen are as follows:

Network 1: Single Source - Single Delivery Gas Pipeline Network System.

Problem 1: Minimizing Fuel Consumption in Compressor at fixed throughput.

In this problem, an eighteen node network connecting a single source to a single delivery point was selected for analysis. A steady state model, incorporating gas flow dynamics, compressor characteristics and mass balance equations were developed. Single objective Ant Colony Optimization was used for optimization. The results obtained using Ant Colony Algorithm for various variables that include pressure at nodes, mass rate in pipe arc, rotational speed of compressors, isentropic head across compressors and isentropic efficiency that lead to fuel consumption calculation in

compressors were presented. Further comparison of the optimal values of variables obtained using Ant Colony Optimization technique with a similar optimization tool; CONOPT Solver was presented. Results show that utilizing Ant Colony optimization technique resulted in saving 352,076.58 USD per year.

Network 1: Single Source and Single Delivery Gas Pipeline Network System

Problem 2: Minimizing Fuel Consumption and Maximizing Throughput at Delivery Station.

For a Natural Gas Delivering Company the demand may vary according to climatic conditions or industrial requirements. So the problem which arises is to determine, for a given supply at the network entrance nodes, the minimal and maximal network capacities in terms of *Natural Gas* mass flow delivery and fuel consumption in compressor stations. This problem has been formulated as a bixobjective optimization problem. For solving the problem, single objective ant-colony optimization algorithm was combined with an adaptive weighted sum method. The detailed algorithm has been presented in the thesis. The non-dominating sorting ant colony algorithm produced a set of Pareto Optimal Solution in the objective space of fuel consumption in compressors and throughput at the delivery station. Different weights were utilized for generating Pareto front. Comparison of the Pareto front of different weights revealed a very crucial information, i.e. the solution obtained does not preserve one's initial preferences of choosing weights no matter how the weights were set. The solution obtained by combining the multiple objective functions to a single objective function depends on the relative magnitude of the objective

functions. This very useful idea has been often overlooked in most of the literature available. When performing the bi-objective optimization, the Pareto front provides an easy way for identifying the minimum and maximum network capacities in terms of mass flow delivery and fuel consumption.

Network 2: Multi Source and Multi Delivery Gas Pipeline Network System

Problem: Minimizing fuel consumption.

A forty five nodal multi-source, multi-delivery pipeline network, consisting of six gas supply stations, nineteen gas delivery terminals, seven compressors and ten valves was considered. A steady state model, incorporating gas flow dynamics, compressor characteristics and mass balance equations were developed. Results of ninety eight variables that include pressure at the nodes, the gas flow rate in pipe arcs, the amount of gas required from source station, gas flow rate through valves and fuel consumption in compressors were presented. Further comparison of the optimal values of variables obtained using Ant Colony Optimization technique with a similar optimization tool; CONOPT Solver was presented. Results show that utilizing Ant Colony optimization technique resulted in decreased fuel consumption of 0.01 kg per second. In economic terms, this reduction would save around 630 thousand USD per year.

6.2 Significance of the work done

The methodology adopted in the thesis can be utilized for manifold purposes. Some of them are as follows:

- i. In this work, compressor stations, which consist of several identical

centrifugal compressor units installed in parallel, were considered. This type of station configuration is very common in today's gas industry. Hence, having an understanding of this type of situation is fundamental for modelling more complex station configurations.

- ii. Complementing the modelling core, Ant Colony algorithm was developed to improve the operating conditions of a gas pipeline network system. The use of the proposed strategy can help the gas network manager to analyze and address the key issues like fuel consumption minimization and throughput maximization in gas pipeline network.
- iii. Depending on the quantity of gas to be delivered at different delivery stations, the pipeline operator will be able to utilize compressors at his disposal most efficiently. This will help in reducing fuel consumption while avoiding choking and surging conditions.
- iv. The strategy developed will also help the pipeline operator to set the consequent pressure at nodes and flow rate in pipe arc to minimize the fuel consumption.
- v. The model and optimization process facilitates the calculation of some key parameters like isentropic head and isentropic efficiency. This helps the operator to analyze the compressors characteristics more efficiently.
- vi. The multiobjective ant colony technique, that was utilized to generate Pareto front, can be utilized for generating Pareto front of any type of gas pipeline network. The Pareto front gives useful information to the pipeline operator,

manager that if a certain quantity of gas is to be delivered at different key points, then how he can utilize the compressors at his disposal most efficiently to reduce the fuel consumption.

vii. The Pareto can be used to determine, for a given supply at the network entrance nodes, the minimal and maximal network capacities in terms of Natural Gas mass flow delivery and corresponding fuel consumption.

viii. Finally, the global framework can help decision making for optimizing the operating conditions of gas networks, anticipating the changes that may occur (i.e. gas quality, variation in supply sources availability and consequences in maintenance).

6.3 Future Work

6.3.1 Resolution Time

Extensive time is required in solving gas pipeline optimization problems. To obtain the optimal solution at a reasonable resolution time, it would be necessary that researchers with different optimization background solve the model with different optimization techniques. A very nice extension of the gas pipeline transportation problem can be to compare the resolution time in solving single and multiobjective problems using different evolutionary techniques.

6.3.2 Solving Multi Objective Problems in a Highly Meshed Gas Pipeline Network.

The Multiobjective methodology proposed in the thesis can be utilized for solving typical Multiobjective problem of Minimizing fuel consumption and maximizing throughput of a Multi supply Multi delivery gas pipeline transportation problem.

6.3.3 Environmental Impacts

Natural gas on burning releases carbon dioxide that is highly responsible for global warming. An interesting extension of the problem taken in the thesis can be a tri-objective optimization problem that includes Minimizing Fuel Consumption, Maximizing Gas Throughput and Minimizing Global Warming Potential in the objective space defined by various equality and inequality constraints.

6.3.4 Optimization Model for Uncertainty in Gas Demand

Gas demand varies with climatic conditions. Another extension that could increase the realism of the model proposed is to consider the uncertainty of gas demand. Fuzzy concepts and Gaussian distribution have been used in the past to describe the imprecise nature of gas demand. This reinforces the interest of using Multiobjective Ant Colony Algorithms, since similar problems were treated previously by using Multiobjective Genetic Algorithm (Lasserre, 2006).

6.3.5 Other evolutionary methods

Other evolutionary procedures, like Particle Swarm, Simulated Annealing, Fire Fly, Cuckoo Search, and Genetic Algorithm should be tested for solving multiobjective optimization problems related to Natural Gas Pipeline Network.

APPENDIX-A

DERIVATION OF PRESSURE DROP EQUATION IN PIPELINE

The equation is derived from the basic energy balance equation applied on a control volume. It can be expressed as:

Change in Internal energy + Change in kinetic energy change in potential energy
+work done on the fluid + heat energy added to the fluid – shaft work done by fluid on
the surroundings = 0.

Thus on a mass basis, the energy balance for a fluid under steady state flow conditions may be written as:

$$dU + \frac{dv^2}{2g_c} + \frac{g}{g_c} dz + d(Pv) + dQ - dw_s = 0$$

$$dU + d(Pv) = TdS + VdP$$

$$TdS + VdP + \frac{dv^2}{2g_c} + \frac{g}{g_c} dz + dQ - dw_s = 0$$

For an ideal process,

$$dS = -\frac{dQ}{T}$$

$$dS \geq -\frac{dQ}{T}$$

$$TdS = -dQ + df_w$$

$$Vdp = \frac{dv^2}{2g_c} + \left(\frac{g}{g_c} dz \right) + df_w - dw_s = 0$$

$$dp + \rho \left(\frac{dv^2}{2g_c} \right) \left(\frac{g}{g_c} dz \right) + df_w = 0$$

$$\frac{\partial P}{\partial x} + \frac{f \rho v^2}{2D} \pm g \rho \sin \alpha + \frac{\partial(\rho v^2)}{\partial x} + \frac{\partial(\rho v)}{\partial t} = 0$$

Now since

$$\rho = \frac{PM}{ZRT}$$

And

$$v = \frac{\dot{m}}{\rho A}$$

So,

$$\rho v^2 = \rho \left(\frac{\dot{m}}{\rho A} \right)^2 = \left(\frac{\dot{m}}{A} \right)^2 \times \frac{1}{\rho} = \left(\frac{\dot{m}}{A} \right)^2 \times \frac{ZRT}{PM}$$

$$\rho v = \frac{\dot{m}}{A}$$

And

$$\frac{\partial P}{\partial x} + \frac{f}{2D} \times \left\{ \left(\frac{\dot{m}}{A} \right)^2 \times \frac{ZRT}{PM} \right\} \pm g \left(\frac{PM}{ZRT} \right) \sin \alpha + \frac{\partial}{\partial x} \times \left\{ \left(\frac{\dot{m}}{A} \right)^2 \times \frac{ZRT}{PM} \right\} + \frac{\partial}{\partial t} \left(\frac{\dot{m}}{A} \right) = 0$$

$$\frac{\partial P}{\partial x} + \frac{f}{2D} \times \left\{ \left(\frac{\dot{m}}{A} \right)^2 \times \frac{ZRT}{PM} \right\} \pm g \left(\frac{PM}{ZRT} \right) \sin \alpha + \frac{R}{MA^2} \frac{\partial}{\partial x} \times \left\{ (\dot{m})^2 \times \frac{ZT}{P} \right\} + \frac{\partial}{\partial t} \left(\frac{\dot{m}}{A} \right) = 0$$

Now using the following mathematical identity

$$\frac{\partial}{\partial x} \left(\frac{ZT}{P} \right) (\dot{m}^2) = \left(\frac{ZT}{P} \right) \times 2\dot{m} \frac{\partial(\dot{m})}{\partial x} + (\dot{m}^2) \frac{\partial}{\partial x} \left(\frac{ZT}{P} \right)$$

$$= 2\dot{m} \left(\frac{ZT}{P} \right) \frac{\partial(\dot{m})}{\partial x} + (\dot{m}^2) ZT \frac{\partial}{\partial x} \left(\frac{1}{P} \right)$$

$$= 2\dot{m} \left(\frac{ZT}{P} \right) \frac{\partial(\dot{m})}{\partial x} - \left(\frac{ZT}{P^2} \right) \frac{\partial P}{\partial x}$$

Hence

$$\frac{\partial}{\partial x} \left(\frac{ZT}{P} \right) (\dot{m}^2) = 2\dot{m} \left(\frac{ZT}{P} \right) \frac{\partial(\dot{m})}{\partial x} - \left(\frac{ZT}{P^2} \right) \frac{\partial P}{\partial x}$$

Now for the flow in one dimension, continuity equation yields:

$$\frac{1}{A} \frac{\partial \dot{m}}{\partial x} + \frac{\partial \rho}{\partial t} = 0$$

$$\frac{1}{A} \frac{\partial \dot{m}}{\partial x} + \frac{\partial}{\partial t} \left(\frac{PM}{ZRT} \right) = 0$$

Or

$$\frac{1}{A} \frac{\partial \dot{m}}{\partial x} + \frac{M}{R} \frac{\partial}{\partial t} \left(\frac{P}{ZT} \right) = 0$$

For a steady state flow

$$\frac{\partial \rho}{\partial t} = 0$$

$$\frac{\partial \dot{m}}{\partial t} = 0$$

$$\frac{\partial \dot{m}}{\partial x} = 0$$

$\dot{m} = \text{Constant}$

$$\frac{\partial P}{\partial x} + \frac{f}{2D} \times \left\{ \left(\frac{\dot{m}}{A} \right)^2 \times \frac{ZRT}{PM} \right\} \pm g \left(\frac{PM}{ZRT} \right) \sin \alpha + \frac{\partial}{\partial x} \times \left\{ \left(\frac{\dot{m}}{A} \right)^2 \times \frac{ZRT}{PM} \right\} + \frac{\partial}{\partial t} \left(\frac{\dot{m}}{A} \right) = 0$$

$$\frac{\partial P}{\partial x} + \frac{f}{2D} \times \left\{ \left(\frac{\dot{m}}{A} \right)^2 \times \frac{ZRT}{PM} \right\} \pm g \left(\frac{PM}{ZRT} \right) \sin \alpha + \frac{R}{MA^2} \frac{\partial}{\partial x} \times \left\{ \frac{zT}{P} \times \dot{m}^2 \right\}$$

But the Mathematical identity is

$$\frac{\partial}{\partial x} \left(\frac{ZT}{P} \right) (\dot{m}^2) = 2\dot{m} \left(\frac{ZT}{P} \right) \frac{\partial (\dot{m})}{\partial x} - \left(\frac{ZT}{P^2} \right) \frac{\partial P}{\partial x}$$

Hence

$$\frac{\partial P}{\partial x} + \frac{f}{2D} \times \left\{ \left(\frac{\dot{m}}{A} \right)^2 \times \frac{ZRT}{PM} \right\} \pm g \left(\frac{PM}{ZRT} \right) \sin \alpha - \frac{R\dot{m}^2}{MA^2} \left\{ \left(\frac{ZT}{P^2} \right) \frac{\partial P}{\partial x} \right\} = 0$$

$$\left(1 - \frac{R\dot{m}^2}{MA^2} \frac{ZT}{P^2} \right) \frac{\partial P}{\partial x} + \frac{f}{2D} \times \left\{ \left(\frac{\dot{m}}{A} \right)^2 \times \frac{ZRT}{PM} \right\} \pm g \left(\frac{PM}{ZRT} \right) \sin \alpha = 0$$

Or

$$\frac{\partial P}{\partial x} = \frac{\frac{f}{2D} \left(\frac{zRT}{PM} \right) \times \left(\frac{\dot{m}}{A} \right)^2 \pm g \left(\frac{PM}{zRT} \right) \sin \alpha}{\left(\frac{R\dot{m}^2}{MA^2} \times \frac{zT}{P^2} \right) - 1}$$

Now assuming:

$$a = \frac{f}{2D} \left(\frac{zRT}{M} \right) \times \left(\frac{\dot{m}}{A} \right)^2$$

$$b = \left(\frac{gM}{zRT} \right) \sin \alpha$$

$$c = \left(\frac{R\dot{m}^2}{M} \times \frac{zT}{A^2} \right)$$

Putting the values of a, b, c

$$\frac{\partial P}{\partial x} = \frac{\frac{a}{P} \pm bP}{\frac{c}{P^2} - 1}$$

$$\frac{\partial P}{\partial x} = P \left(\frac{a \pm bP^2}{c - P^2} \right)$$

Now since the variation of pressure is with x only,

Hence the partial derivative

$$\frac{\partial P}{\partial x} = \frac{dP}{dx} = P \left(\frac{a \pm bP^2}{c - P^2} \right)$$

Or

$$dx = \frac{1}{P} \left(\frac{c - P^2}{a \pm bP^2} \right) dP$$

$$dx = \frac{1}{P} \left(\frac{c}{a \pm bP^2} \right) dP - \frac{1}{P} \left(\frac{P^2}{a \pm bP^2} \right) dP$$

$$dx = \frac{1}{P} \left(\frac{c}{a \pm bP^2} \right) dP - \left(\frac{P}{a \pm bP^2} \right) dP$$

And

$$dx = c \times Idp - IIdp$$

$$I = \frac{1}{P} \left(\frac{1}{a \pm bP^2} \right)$$

$$II = \left(\frac{P}{a \pm bP^2} \right) dP$$

Solving for I:

$$\frac{1}{P} \left(\frac{1}{a \pm bP^2} \right) = \frac{r}{P} + \left(\frac{sP+t}{a \pm bP^2} \right) = \frac{ra \pm rbP^2 + sP^2 + Pt}{P(a \pm bP^2)}$$

$$1 = ra \pm rbP^2 + sP^2 + Pt$$

$$1 = ra + P^2(s \pm rb) + Pt$$

$$r = \frac{1}{a}$$

$$s \pm rb = 0$$

$$s \pm \frac{b}{a} = 0$$

$$s = - \left(\pm \frac{b}{a} \right)$$

$$t = 0$$

So the equation reduces to:

$$\frac{1}{P} \left(\frac{1}{a \pm bP^2} \right) = \frac{1}{aP} + \frac{\left\{ - \left(\pm \frac{b}{a} \right) \right\} + 0}{a \pm bP^2}$$

$$\frac{1}{P} \left(\frac{1}{a \pm bP^2} \right) = \frac{1}{aP} - \left\{ \frac{\left(\pm \frac{b}{a} \right) P}{a \pm bP^2} \right\}$$

So,

$$dx = c \left[\frac{1}{aP} - \left\{ \frac{\left(\pm \frac{b}{a} \right) P}{a \pm bP^2} \right\} \right] dp - \left(\frac{P}{a \pm bP^2} \right) dP$$

$$\int_0^L dx = \int_{P_1}^{P_2} c \left[\frac{1}{aP} - \left\{ \frac{\left(\pm \frac{b}{a} \right) P}{a \pm bP^2} \right\} \right] dp - \int_{P_1}^{P_2} \left(\frac{P}{a \pm bP^2} \right) dP$$

$$L = \frac{c}{a} \ln \left(\frac{P_2}{P_1} \right) - \left\{ \pm \left(\frac{bc}{a} \right) \frac{\ln(a \pm bP^2)}{2b} + \frac{\ln(a \pm bP^2)}{2b} \right\}_{P_1}^{P_2}$$

$$L = \frac{c}{a} \ln \left(\frac{P_2}{P_1} \right) - \frac{\left(1 \pm \left(\frac{bc}{a} \right) \right)}{\pm 2b} \ln \left(\frac{a \pm bP_2^2}{a \pm bP_1^2} \right)$$

Now putting the values of

$$\frac{c}{a} = \frac{2D}{f}$$

$$\frac{cb}{a} = \frac{2DgM \sin \alpha}{fzRT}$$

$$\frac{1 \pm \left(\frac{bc}{a} \right)}{\pm 2b} = \frac{\left(1 \pm \frac{2DgM \sin \alpha}{fzRT} \right) zRT}{\pm 2gM \sin \alpha} = \frac{fzRT \pm 2DgM \sin \alpha}{\pm 2fgM \sin \alpha}$$

$$L = \frac{2D}{f} \ln \left(\frac{P_2}{P_1} \right) - \frac{fzRT \pm 2DgM \sin \alpha}{\pm 2fgM \sin \alpha} \ln \left\{ \frac{f(zRT)^2 \dot{m}^2 \pm 2DgM^2 A^2 P_2^2 \sin \alpha}{f(zRT)^2 \dot{m}^2 \pm 2DgM^2 A^2 P_1^2 \sin \alpha} \right\}$$

For vertical upward flow +sign is taken:

$$L = \frac{2D}{f} \ln \left(\frac{P_2}{P_1} \right) - \frac{fzRT + 2DgM \sin \alpha}{+2fgM \sin \alpha} \ln \left\{ \frac{f(zRT)^2 \dot{m}^2 + 2DgM^2 A^2 P_2^2 \sin \alpha}{f(zRT)^2 \dot{m}^2 + 2DgM^2 A^2 P_1^2 \sin \alpha} \right\}$$

For vertical downward flow – sign is taken

$$L = \frac{2D}{f} \ln \left(\frac{P_2}{P_1} \right) + \frac{fzRT + 2DgM \sin \alpha}{2fgM \sin \alpha} \ln \left\{ \frac{f(zRT)^2 \dot{m}^2 - 2DgM^2 A^2 P_2^2 \sin \alpha}{f(zRT)^2 \dot{m}^2 - 2DgM^2 A^2 P_1^2 \sin \alpha} \right\}$$

For horizontal flow

$$\sin \alpha = 0$$

Hence from the equation:

$$\left(1 - \frac{R\dot{m}^2 ZT}{MA^2 P^2}\right) \frac{\partial P}{\partial x} + \frac{f}{2D} \times \left\{ \left(\frac{\dot{m}}{A}\right)^2 \times \frac{ZRT}{PM} \right\} \pm g \left(\frac{PM}{ZRT}\right) \times 0 = 0$$

$$\left(P - \frac{R\dot{m}^2 ZT}{MA^2 P}\right) \frac{\partial P}{\partial x} + \frac{f}{2D} \times \left\{ \left(\frac{\dot{m}}{A}\right)^2 \times \frac{ZRT}{M} \right\} = 0$$

$$\int_{P_1}^{P_2} \left(\frac{R\dot{m}^2 ZT}{MA^2 P} - P\right) \partial P = \int_0^L \frac{f}{2D} \frac{ZRT}{M} \left(\frac{\dot{m}}{A}\right)^2 \partial x$$

$$\frac{R\dot{m}^2 zT}{MA^2} \ln\left(\frac{P_2}{P_1}\right) - \left(\frac{P_2^2 - P_1^2}{2}\right) = \frac{f}{2D} \frac{ZRT}{M} \left(\frac{\dot{m}}{A}\right)^2 L$$

$$A = \frac{\pi D^2}{4}$$

$$\frac{R\dot{m}^2 zT}{M \left(\frac{\pi D^2}{4}\right)^2} \ln\left(\frac{P_2}{P_1}\right) - \left(\frac{P_2^2 - P_1^2}{2}\right) = \frac{f}{2D} \frac{ZRT}{M} \left(\frac{\dot{m}}{\frac{\pi D^2}{4}}\right)^2 L$$

$$\frac{4R\dot{m}^2 zT}{M (\pi D^2)^2} \ln\left(\frac{P_2}{P_1}\right) - \left(\frac{P_2^2 - P_1^2}{2}\right) = \frac{f}{2D} \frac{ZRT}{M} \left(\frac{4\dot{m}}{\pi D^2}\right)^2 L$$

On further simplification:

$$\left(P_2^2 - P_1^2\right) - 32 \left(\frac{\dot{m}^2 zRT}{\pi^2 D^4 M}\right) \ln\left(\frac{P_2}{P_1}\right) + \left(\frac{16 fzRT}{\pi^2 D^5 M}\right) \dot{m}^2 L = 0$$

Above is the equation of motion between two points in the pipeline.

APPENDIX B

DERIVATION OF AVERAGE GAS PRESSURE IN PIPELINE

For an incompressible fluid flowing in pipeline, average pressure is obtained by taking the arithmetic mean of inlet and outlet pressure. As shown in the figure, if P_1 is the inlet pressure and P_2 is the outlet pressure, then the average pressure is obtained from:

$$\left(\frac{P_1 + P_2}{2} \right)$$

However, the above equation is valid only when the density of gas remains constant with the change in temperature and pressure. For the cases where the density varies with temperature and pressure, the above equation is not valid. In the following section derivation of average pressure equation in pipeline is given.

Derivation

Consider a cross-country pipeline of length L as shown in figure. Now to find the pressure at a particular point x, which is located at a particular point along the length of pipeline, Weymouth equation is used.

$$Q = 3.7435 \times 10^{-3} E \left(\frac{T_b}{P_b} \right) \left(\frac{P_1^2 - P_x^2}{GTLxz} \right)^{0.5} \times D^{2.667}$$

Now the flow rate between the point x and delivery point B is obtained from:

$$Q = 3.7435 \times 10^{-3} E \left(\frac{T_b}{P_b} \right) \left(\frac{P_x^2 - P_2^2}{GTL(1-x)z} \right)^{0.5} \times D^{2.667}$$

Now since for a series pipeline segment, flow rate Q remains constant.

So from the above two equations:

$$\frac{P_1^2 - P_x^2}{x} = \frac{P_x^2 - P_2^2}{1-x}$$

Solving for P_x

$$P_x = \left[P_1^2 - x(P_1^2 - P_2^2) \right]^{0.5}$$

Pressure drop for the entire length of pipeline is obtained from:

$$P_{av} = \int_0^L P_x dx = \int_0^L \left[P_1^2 - x(P_1^2 - P_2^2) \right]^{0.5} dx$$

$$P_{av} = \frac{2}{3} \left(P_1 + \frac{P_2^2}{P_1 + P_2} \right) = \frac{2}{3} \left(\frac{P_1^2 + P_1 P_2 + P_2^2}{P_1 + P_2} \right)$$

Above equation can be written as:

$$P_{av} = \frac{2}{3} \left(\frac{P_1^2 + P_1P_2 + P_1P_2 + P_2^2 - P_1P_2}{P_1 + P_2} \right)$$

Or

$$P_{av} = \frac{2}{3} \left[\frac{(P_1 + P_2)^2 - P_1P_2}{P_1 + P_2} \right]$$

Or

$$P_{av} = \frac{2}{3} \left[\frac{(P_1 + P_2)^2}{P_1 + P_2} - \frac{P_1P_2}{P_1 + P_2} \right]$$

$$P_{av} = \frac{2}{3} \left[(P_1 + P_2) - \frac{P_1P_2}{P_1 + P_2} \right]$$

APPENDIX – C

DERIVATION OF GAS VELOCITY EQUATION IN PIPELINES

Consider a pipe segment as shown in figure transporting gas from point A to point B as shown in figure.

There is no injection or deliveries between point 1 and 2. If the process is considered at steady state then the mass flow rate between the two points A and B remains constant.

$$\dot{m}_1 = \dot{m}_2$$

Simplifying

$$\rho_1 A_1 v_1 = \rho_2 A_2 v_2$$

Now if the cross section of the pipeline is same throughout the segment then,

$$\rho_1 v_1 = \rho_2 v_2$$

If at inlet conditions the volumetric flow rate of gas Q at standard conditions 0.1MPa and 15⁰C are known, then the velocity of the gas at any point along the pipeline at which pressure and temperature of the gas are P and T can be calculated.

The velocity of gas at section 1 is related to the flow rate Q_1 and pipe cross sectional area A as follows:

$$Q_1 = u_1 A$$

Since the mass flow rate is same along the whole pipeline segment, hence

$$M = Q_1 \rho_1 = Q_2 \rho_2 = Q_b \rho_b$$

Where Q_b the gas is flow rate at standard conditions and ρ_b is the corresponding gas density.

Therefore simplifying the above equation yields:

$$Q_1 = Q_b \left(\frac{\rho_b}{\rho_1} \right)$$

Now applying the gas law at inlet and outlet

$$\frac{P_1}{\rho_1} = z_1 R T_1$$

Or

$$\rho_1 = \frac{P_1}{z_1 R T_1}$$

Similarly at standard conditions:

$$\rho_b = \frac{P_b}{z_b R T_b}$$

Putting the values in gas flow equation at inlet yields,

$$Q_1 = Q_b \left(\frac{P_b}{T_b} \right) \left(\frac{T_1}{P_1} \right) \left(\frac{z_1}{z_b} \right)$$

Now since

$$Q_1 = u_1 A$$

Hence

$$u_1 = \frac{Q_1}{A}$$

Putting the value of Q_1 , yields

$$u_1 = Q_b \left(\frac{P_b}{T_b} \right) \left(\frac{T_1}{P_1} \right) \left(\frac{z_1}{A} \right)$$

Or

$$u_1 = Q_b \left(\frac{P_b}{T_b} \right) \left(\frac{T_1}{P_1} \right) \left(\frac{4z_1}{\pi D^2} \right)$$

Or

$$u_1 = Q_b \left(\frac{P_b}{T_b} \right) \left(\frac{z_1 T_1}{P_1} \right) \left(\frac{4}{\pi D^2} \right)$$

Or

$$u_1 = 14.7349 \left(\frac{P_b}{T_b} \right) \left(\frac{z_1 T_1}{P_1} \right) \left(\frac{Q_b}{D^2} \right)$$

$$u = 14.7349 \left(\frac{P_b}{T_b} \right) \left(\frac{zT}{P} \right) \left(\frac{Q_b}{D^2} \right)$$

APPENDIX-D

DERIVATION FOR ISENTROPIC EFFICIENCY OF COMPRESSORS

Consider the figure shown on enthalpy-pressure plot. The gas is at a temperature of T and is compressed isentropically to a Temperature of T' . But the gas compresses actually to a temperature of T .

Figure: Enthalpy-Entropy Diagram for Compressor

Polytropic efficiency is the ratio of temperature rise in isentropic process to polytropic process.

$$\eta_{sc} = \frac{\partial T'}{\partial T} = C$$

Here C is a constant.

$$\eta_{\infty c} \partial T = \partial T'$$

For a polytropic process

$$PV^{n_p} = C$$

Or

$$T = C(P)^{\frac{n_p-1}{n_p}}$$

The above equation can be written as

$$\ln T = \ln C + \left(\frac{n_p - 1}{n_p} \right) \ln P$$

Differentiating the above equation yields

$$\frac{\partial T}{T} = \left(\frac{n_p - 1}{n_p} \right) \frac{\partial P}{P}$$

In the same way, following equation for isentropic equation can be written:

$$\frac{\partial T'}{T} = \left(\frac{k - 1}{k} \right) \frac{\partial P}{P}$$

Dividing the above two equation yields:

$$\frac{\partial T'}{\partial T} = \left(\frac{\frac{k-1}{k}}{\frac{n_p-1}{n_p}} \right)$$

Hence the equation for polytropic process yields

$$\eta_{\infty c} = \frac{\partial T'}{\partial T} = \frac{\left(\frac{k-1}{k}\right)}{\left(\frac{n_p-1}{n_p}\right)}$$

Also from equation A

$$\frac{\eta_{\infty c} \partial T}{T} = \left(\frac{k-1}{k}\right) \frac{\partial P}{P}$$

For expansion from state 1 to state 2:

$$\eta_{\infty c} \ln\left(\frac{T_2}{T_1}\right) = \left(\frac{k-1}{k}\right) \ln\left(\frac{P_2}{P_1}\right)$$

Or

$$\ln\left(\frac{T_2}{T_1}\right) = \left(\frac{k-1}{k\eta_{\infty c}}\right) \ln\left(\frac{P_2}{P_1}\right)$$

Or

$$\ln\left(\frac{T_2}{T_1}\right) = \ln\left(\frac{P_2}{P_1}\right)^{\left(\frac{k-1}{k\eta_{\infty c}}\right)}$$

Or

$$\left(\frac{T_2}{T_1}\right) = \left(\frac{P_2}{P_1}\right)^{\left(\frac{k-1}{k\eta_{\infty c}}\right)}$$

For an isentropic process $\eta_{\infty c} = 1$.

Hence

$$\left(\frac{T_{2s}}{T_1}\right) = \left(\frac{P_2}{P_1}\right)^{\left(\frac{k-1}{k}\right)}$$

$$\eta_c = \frac{T_{2s} - T_1}{T_2 - T_1} = \frac{\frac{T_{2s}}{T_1} - 1}{\frac{T_2}{T_1} - 1}$$

$$\eta_c = \frac{\left(\frac{P_2}{P_1}\right)^{\left(\frac{k-1}{k}\right)} - 1}{\left(\frac{P_2}{P_1}\right)^{\left(\frac{k-1}{k\eta_{oc}}\right)} - 1}$$

But

$$\eta_{oc} = \frac{\left(\frac{k-1}{k}\right)}{\left(\frac{n_p-1}{n_p}\right)}$$

Hence

$$\eta_c = \frac{\left(\frac{P_2}{P_1}\right)^{\left(\frac{k-1}{k}\right)} - 1}{\left(\frac{P_2}{P_1}\right)^{\left(\frac{n_p-1}{n_p}\right)} - 1}$$

APPENDIX-E

DERIVATION OF FUEL CONSUMED IN COMPRESSORS

Let us consider a gas flowing in pipeline in which $\frac{dE_{cv}}{dt}$ is the change in Internal Energy of the gas per unit time, Q_{cv} is heat transfer to or from the control volume per unit time, W_{cv} is the work done by or on the system per unit time, V_i and V_j are the velocity of gas, h_i and h_j is the head, z_i and z_j are the elevations, m_i , and m_j are the mass rate per second of gas, each being at inlet and outlet of the compressor.

The Unsteady State Energy Balance Equation on the control volume is:

$$\frac{dE_{cv}}{dt} = Q_{cv} - W_{cv} + \sum m_i \left(h_i + \frac{V_i^2}{2} + g \times z_i \right) - \sum m_j \left(h_j + \frac{V_j^2}{2} + g \times z_j \right)$$

(a)

Assumptions:

- i. Process is at steady state, so $\frac{dE_{cv}}{dt} = 0$ and mass flow rate of gas at inlet to the compressor and at outlet of the compressor remains same.
- ii. Process is adiabatic, so $Q_{cv} = 0$.
- iii. Change in Potential Energy and kinetic energy is negligible.

Under the above mentioned assumptions, the unsteady state energy balance equation

(a) reduces to:

$$0 = -W_{cv} + m_j \times (h_i - h_j)$$

(b)

Also, since in the compression process work is done on the constant mass of gas,

hence

$$W_{comp-ideal} = -W_{cv} = m_j \times (h_j - h_i) = m_j \times h_{ij}$$

(c)

In the above equation, h_{ij} is called the isentropic head and is a function of discharge to suction pressure. The equation to obtain isentropic head will be explained in the subsequent section. The total actual work required in compressing the gas, is obtained by dividing the ideal work by the isentropic efficiency η_{is} , driver efficiency η_d and mechanical efficiency η_m . Hence, the total Actual work required for compression of gas is

$$(m_j \times h_{ij}) \times \left(\frac{10^2}{\eta_{is}} \times \frac{10^2}{\eta_d} \times \frac{10^2}{\eta_m} \right) \quad (d)$$

Now if H_m is the lower heating value of gas and m_f be the fuel consumed in the compressor then the total energy released from combustion per unit time is

$$H_m \times m_f \quad (e)$$

$$\text{Thus } m_f = \left(\frac{m_j \times h_{ij}}{H_m} \right) \times \left(\frac{10^2}{\eta_{is}} \times \frac{10^2}{\eta_d} \times \frac{10^2}{\eta_m} \right)$$

Above equation is used for calculating the fuel consumed in compressors.

APPENDIX- F

DERIVATION OF SURGE EQUATION IN COMPRESSORS

$$\left(\frac{P_d}{P_s}\right) = 1 + \lambda m_s^2$$

$$h_s = \left(\frac{z_s RT_s}{M}\right) \left(\frac{k}{k-1}\right) \left\{ \left(\frac{P_d}{P_s}\right)^{\frac{k-1}{k}} - 1 \right\}$$

$$\left(\frac{P_d}{P_s}\right) = \left\{ \frac{M}{z_s RT_s} \left(\frac{k-1}{k}\right) h_s + 1 \right\}^{\frac{k}{k-1}}$$

$$1 + \lambda m_s^2 = \left\{ \frac{M}{z_s RT_s} \left(\frac{k-1}{k}\right) h_s + 1 \right\}^{\frac{k}{k-1}}$$

$$\lambda m_s^2 = \left\{ \frac{M}{z_s RT_s} \left(\frac{k-1}{k}\right) h_s + 1 \right\}^{\frac{k}{k-1}} - 1$$

$$m_s^2 = \frac{1}{\lambda} \left[\left\{ \frac{M}{z_s RT_s} \left(\frac{k-1}{k}\right) h_s + 1 \right\}^{\frac{k}{k-1}} - 1 \right]$$

$$m_s = \frac{1}{\lambda^{1/2}} \left[\left\{ \frac{M}{z_s RT_s} \left(\frac{k-1}{k}\right) h_s + 1 \right\}^{\frac{k}{k-1}} - 1 \right]^{1/2}$$

$$Q_s = \frac{\dot{m}_s}{\rho_s} = \frac{1}{\rho_s \lambda^{1/2}} \left[\left\{ \frac{M}{z_s RT_s} \left(\frac{k-1}{k}\right) h_s + 1 \right\}^{\frac{k}{k-1}} - 1 \right]^{1/2}$$

$$\rho_s = \frac{P_s M}{z_s RT}$$

$$Q_s = \frac{z_s RT}{P_s M} \frac{1}{\lambda^{1/2}} \left[\left\{ \frac{M}{z_s RT_s} \left(\frac{k-1}{k} \right) h_s + 1 \right\}^{\frac{k}{k-1}} - 1 \right]^{1/2}$$

$$Q_s = \frac{1}{\lambda^{1/2}} \left[\left(\frac{z_s RT}{P_s M} \right)^2 \left\{ \frac{M}{z_s RT_s} \left(\frac{k-1}{k} \right) h_s + 1 \right\}^{\frac{k}{k-1}} - \left(\frac{z_s RT}{P_s M} \right)^2 \right]^{1/2}$$

$$Q_s = \frac{1}{\lambda^{1/2}} \left[\left\{ \left(\frac{z_s RT}{P_s M} \right)^{\frac{2}{k(k-1)}} \frac{M}{z_s RT_s} \left(\frac{k-1}{k} \right) h_s + \left(\frac{z_s RT}{P_s M} \right)^{\frac{2}{k(k-1)}} \right\}^{\frac{k}{k-1}} - \left(\frac{z_s RT}{P_s M} \right)^2 \right]^{1/2}$$

$$Q_s = \frac{1}{\lambda^{1/2}} \left[\left\{ \frac{z_s RT}{P_s^2 M} \left(\frac{k-1}{k} \right) h_s + \left(\frac{z_s RT}{P_s M} \right)^2 \right\}^{\frac{k}{k-1}} - \left(\frac{z_s RT}{P_s M} \right)^2 \right]^{1/2}$$

SUPPLEMENTRY TABLE 1
DENSITY OF GAS IN PIPE ARCS

S. No.	Arc No.	Average Density in Pipe Segments
1	$N_0 - N_1$	$\rho_1 = \frac{P_{01} \times M}{Z_1 \times R \times T}$
2	$N_1 - N_2$	$\rho_2 = \frac{P_{12} \times M}{Z_2 \times R \times T}$
3	$N_1 - N_3$	$\rho_3 = \frac{P_{13} \times M}{Z_3 \times R \times T}$
4	$N_1 - N_4$	$\rho_4 = \frac{P_{14} \times M}{Z_4 \times R \times T}$

5	$N_5 - N_8$	$\rho_5 = \frac{P_{58} \times M}{Z_5 \times R \times T}$
6	$N_6 - N_8$	$\rho_6 = \frac{P_{68} \times M}{Z_6 \times R \times T}$
7	$N_7 - N_8$	$\rho_7 = \frac{P_{78} \times M}{Z_7 \times R \times T}$
8	$N_8 - N_9$	$\rho_8 = \frac{P_{89} \times M}{Z_8 \times R \times T}$
9	$N_9 - N_{10}$	$\rho_9 = \frac{P_{910} \times M}{Z_9 \times R \times T}$
10	$N_9 - N_{11}$	$\rho_{10} = \frac{P_{911} \times M}{Z_{10} \times R \times T}$
11	$N_9 - N_{12}$	$\rho_{11} = \frac{P_{912} \times M}{Z_{11} \times R \times T}$
12	$N_{13} - N_{16}$	$\rho_{12} = \frac{P_{1316} \times M}{Z_{12} \times R \times T}$
13	$N_{14} - N_{16}$	$\rho_{13} = \frac{P_{1416} \times M}{Z_{13} \times R \times T}$
14	$N_{15} - N_{16}$	$\rho_{14} = \frac{P_{1516} \times M}{Z_{14} \times R \times T}$
15	$N_{16} - N_{17}$	$\rho_{15} = \frac{P_{1617} \times M}{Z_{15} \times R \times T}$

SUPPLEMENTRY TABLE 2
AVERAGE PRESSURE IN PIPE SEGMENT

S. No.	Arc No.	Average Pressure in Pipe Segments
1	$N_0 - N_1$	$P_{01} = \left(\frac{2}{3}\right) \times \left[P_0 + P_1 - \frac{P_0 \times P_1}{P_0 + P_1} \right]$
2	$N_1 - N_2$	$P_{12} = \left(\frac{2}{3}\right) \times \left[P_1 + P_2 - \frac{P_1 \times P_2}{P_1 + P_2} \right]$
3	$N_1 - N_3$	$P_{13} = \left(\frac{2}{3}\right) \times \left[P_1 + P_3 - \frac{P_1 \times P_3}{P_1 + P_3} \right]$
4	$N_1 - N_4$	$P_{14} = \left(\frac{2}{3}\right) \times \left[P_1 + P_4 - \frac{P_1 \times P_4}{P_1 + P_4} \right]$
5	$N_5 - N_8$	$P_{58} = \left(\frac{2}{3}\right) \times \left[P_5 + P_8 - \frac{P_5 \times P_8}{P_5 + P_8} \right]$
6	$N_6 - N_8$	$P_{68} = \left(\frac{2}{3}\right) \times \left[P_6 + P_8 - \frac{P_6 \times P_8}{P_6 + P_8} \right]$
7	$N_7 - N_8$	$P_{78} = \left(\frac{2}{3}\right) \times \left[P_7 + P_8 - \frac{P_7 \times P_8}{P_7 + P_8} \right]$
8	$N_8 - N_9$	$P_{89} = \left(\frac{2}{3}\right) \times \left[P_8 + P_9 - \frac{P_8 \times P_9}{P_8 + P_9} \right]$
9	$N_9 - N_{10}$	$P_{910} = \left(\frac{2}{3}\right) \times \left[P_9 + P_{10} - \frac{P_9 \times P_{10}}{P_9 + P_{10}} \right]$

10	$N_9 - N_{11}$	$P_{0911} = \left(\frac{2}{3}\right) \times \left[P_9 + P_{11} - \frac{P_9 \times P_{11}}{P_9 + P_{11}} \right]$
11	$N_{09} - N_{12}$	$P_{0912} = \left(\frac{2}{3}\right) \times \left[P_{09} + P_{12} - \frac{P_{09} \times P_{12}}{P_{09} + P_{12}} \right]$
12	$N_{13} - N_{16}$	$P_{1316} = \left(\frac{2}{3}\right) \times \left[P_{13} + P_{16} - \frac{P_{13} \times P_{16}}{P_{13} + P_{16}} \right]$
13	$N_{14} - N_{16}$	$P_{1416} = \left(\frac{2}{3}\right) \times \left[P_{14} + P_{16} - \frac{P_{14} \times P_{16}}{P_{14} + P_{16}} \right]$
14	$N_{15} - N_{16}$	$P_{1516} = \left(\frac{2}{3}\right) \times \left[P_{15} + P_{16} - \frac{P_{15} \times P_{16}}{P_{15} + P_{16}} \right]$
15	$N_{16} - N_{17}$	$P_{1617} = \left(\frac{2}{3}\right) \times \left[P_{16} + P_{17} - \frac{P_{16} \times P_{17}}{P_{16} + P_{17}} \right]$

SUPPLEMENTRY TABLE 3
VELOCITY OF GAS IN PIPE SEGMENTS

S. No.	Arc No.	Equation for Velocity in Pipe Segments
1	$N_0 - N_1$	$v_1 = 14.7359 \times \left(\frac{Q_1 \times 24 \times 3600}{(D_o \times 10^3 - 2 \times t_1 \times 10^3)^2} \right) \times \left(\frac{P_b}{T_b} \right) \times \left(\frac{z_1 \times T}{P_{01} \times 10^2} \right)$
2	$N_1 - N_2$	$v_2 = 14.7359 \times \left(\frac{Q_2 \times 24 \times 3600}{(D_o \times 10^3 - 2 \times t_2 \times 10^3)^2} \right) \times \left(\frac{P_b}{T_b} \right) \times \left(\frac{z_2 \times T}{P_{12} \times 10^2} \right)$
3	$N_1 - N_3$	$v_3 = 14.7359 \times \left(\frac{Q_3 \times 24 \times 3600}{(D_o \times 10^3 - 2 \times t_3 \times 10^3)^2} \right) \times \left(\frac{P_b}{T_b} \right) \times \left(\frac{z_3 \times T}{P_{13} \times 10^2} \right)$
4	$N_1 - N_4$	$v_4 = 14.7359 \times \left(\frac{Q_4 \times 24 \times 3600}{(D_o \times 10^3 - 2 \times t_4 \times 10^3)^2} \right) \times \left(\frac{P_b}{T_b} \right) \times \left(\frac{z_4 \times T}{P_{14} \times 10^2} \right)$
5	$N_5 - N_8$	$v_5 = 14.7359 \times \left(\frac{Q_5 \times 24 \times 3600}{(D_o \times 10^3 - 2 \times t_5 \times 10^3)^2} \right) \times \left(\frac{P_b}{T_b} \right) \times \left(\frac{z_5 \times T}{P_{58} \times 10^2} \right)$
6	$N_6 - N_8$	$v_6 = 14.7359 \times \left(\frac{Q_6 \times 24 \times 3600}{(D_o \times 10^3 - 2 \times t_6 \times 10^3)^2} \right) \times \left(\frac{P_b}{T_b} \right) \times \left(\frac{z_6 \times T}{P_{68} \times 10^2} \right)$
7	$N_7 - N_8$	$v_7 = 14.7359 \times \left(\frac{Q_7 \times 24 \times 3600}{(D_o \times 10^3 - 2 \times t_7 \times 10^3)^2} \right) \times \left(\frac{P_b}{T_b} \right) \times \left(\frac{z_7 \times T}{P_{78} \times 10^2} \right)$
8	$N_8 - N_9$	$v_8 = 14.7359 \times \left(\frac{Q_8 \times 24 \times 3600}{(D_o \times 10^3 - 2 \times t_8 \times 10^3)^2} \right) \times \left(\frac{P_b}{T_b} \right) \times \left(\frac{z_8 \times T}{P_{89} \times 10^2} \right)$
9	$N_9 - N_{10}$	$v_9 = 14.7359 \times \left(\frac{Q_9 \times 24 \times 3600}{(D_o \times 10^3 - 2 \times t_9 \times 10^3)^2} \right) \times \left(\frac{P_b}{T_b} \right) \times \left(\frac{z_9 \times T}{P_{910} \times 10^2} \right)$

10	$N_9 - N_{11}$	$v_{10} = 14.7359 \times \left(\frac{Q_{10} \times 24 \times 3600}{(D_o \times 10^3 - 2 \times t_{10} \times 10^3)^2} \right) \times \left(\frac{P_b}{T_b} \right) \times \left(\frac{z_{10} \times T}{P_{911} \times 10^2} \right)$
11	$N_9 - N_{12}$	$v_{11} = 14.7359 \times \left(\frac{Q_{11} \times 24 \times 3600}{(D_o \times 10^3 - 2 \times t_{11} \times 10^3)^2} \right) \times \left(\frac{P_b}{T_b} \right) \times \left(\frac{z_{11} \times T}{P_{912} \times 10^2} \right)$
12	$N_{13} - N_{16}$	$v_{12} = 14.7359 \times \left(\frac{Q_{12} \times 24 \times 3600}{(D_o \times 10^3 - 2 \times t_{12} \times 10^3)^2} \right) \times \left(\frac{P_b}{T_b} \right) \times \left(\frac{z_{12} \times T}{P_{1316} \times 10^2} \right)$
13	$N_{14} - N_{16}$	$v_{13} = 14.7359 \times \left(\frac{Q_{13} \times 24 \times 3600}{(D_o \times 10^3 - 2 \times t_{13} \times 10^3)^2} \right) \times \left(\frac{P_b}{T_b} \right) \times \left(\frac{z_{13} \times T}{P_{1416} \times 10^2} \right)$
14	$N_{15} - N_{16}$	$v_{14} = 14.7359 \times \left(\frac{Q_{14} \times 24 \times 3600}{(D_o \times 10^3 - 2 \times t_{14} \times 10^3)^2} \right) \times \left(\frac{P_b}{T_b} \right) \times \left(\frac{z_{14} \times T}{P_{1516} \times 10^2} \right)$
15	$N_{16} - N_{17}$	$v_{15} = 14.7359 \times \left(\frac{Q_{15} \times 24 \times 3600}{(D_o \times 10^3 - 2 \times t_{15} \times 10^3)^2} \right) \times \left(\frac{P_b}{T_b} \right) \times \left(\frac{z_{15} \times T}{P_{1617} \times 10^2} \right)$

SUPPLEMENTARY TABLE 4
CALCULATION OF COMPRESSIBILITY FACTOR

S. No.	Arc No.	Average Pressure in Pipe Segments
1	$N_0 - N_1$	$z_1 = 1 + \left(0.257 - 0.533 \times \frac{T_C}{T} \right) \times \frac{P_{01}}{P_C}$
2	$N_1 - N_2$	$z_2 = 1 + \left(0.257 - 0.533 \times \frac{T_C}{T} \right) \times \frac{P_{12}}{P_C}$
3	$N_1 - N_3$	$z_3 = 1 + \left(0.257 - 0.533 \times \frac{T_C}{T} \right) \times \frac{P_{13}}{P_C}$
4	$N_1 - N_4$	$z_4 = 1 + \left(0.257 - 0.533 \times \frac{T_C}{T} \right) \times \frac{P_{14}}{P_C}$
5	$N_5 - N_8$	$z_5 = 1 + \left(0.257 - 0.533 \times \frac{T_C}{T} \right) \times \frac{P_{58}}{P_C}$
6	$N_6 - N_8$	$z_6 = 1 + \left(0.257 - 0.533 \times \frac{T_C}{T} \right) \times \frac{P_{68}}{P_C}$
7	$N_7 - N_8$	$z_7 = 1 + \left(0.257 - 0.533 \times \frac{T_C}{T} \right) \times \frac{P_{78}}{P_C}$
8	$N_8 - N_9$	$z_8 = 1 + \left(0.257 - 0.533 \times \frac{T_C}{T} \right) \times \frac{P_{89}}{P_C}$
9	$N_9 - N_{10}$	$z_9 = 1 + \left(0.257 - 0.533 \times \frac{T_C}{T} \right) \times \frac{P_{910}}{P_C}$
10	$N_9 - N_{11}$	$z_{10} = 1 + \left(0.257 - 0.533 \times \frac{T_C}{T} \right) \times \frac{P_{911}}{P_C}$
11	$N_9 - N_{12}$	$z_{11} = 1 + \left(0.257 - 0.533 \times \frac{T_C}{T} \right) \times \frac{P_{912}}{P_C}$
12	$N_{13} - N_{16}$	$z_{12} = 1 + \left(0.257 - 0.533 \times \frac{T_C}{T} \right) \times \frac{P_{1316}}{P_C}$

13	$N_{14} - N_{16}$	$z_{13} = 1 + \left(0.257 - 0.533 \times \frac{T_C}{T} \right) \times \frac{P_{1416}}{P_C}$
14	$N_{15} - N_{16}$	$z_{14} = 1 + \left(0.257 - 0.533 \times \frac{T_C}{T} \right) \times \frac{P_{1516}}{P_C}$
15	$N_{16} - N_{17}$	$z_{15} = 1 + \left(0.257 - 0.533 \times \frac{T_C}{T} \right) \times \frac{P_{1617}}{P_C}$

SUPPLEMENTARY TABLE 5
PRESSURE DROP EQUATION IN PIPE ARC

S. No.	Arc No.	Pressure Drop Equation in Pipe Segments
1	$N_0 - N_1$	$P_0^2 - P_1^2 = \frac{32 \times m_1^2 \times z_1 \times R \times T \times \log_{10} \left(\frac{P_0}{P_1} \right)}{\pi^2 \times D_1^4 \times M} - \frac{16 \times f_1 \times z_1 \times m_1^2 \times R \times T \times L_1}{\pi^2 \times D_1^5 \times M}$
2	$N_1 - N_2$	$P_1^2 - P_2^2 = \frac{32 \times m_2^2 \times z_2 \times R \times T \times \log_{10} \left(\frac{P_1}{P_2} \right)}{\pi^2 \times D_2^4 \times M} - \frac{16 \times f_2 \times z_2 \times m_2^2 \times R \times T \times L_2}{\pi^2 \times D_2^5 \times M}$
3	$N_1 - N_3$	$P_1^2 - P_3^2 = \frac{32 \times m_3^2 \times z_3 \times R \times T \times \log_{10} \left(\frac{P_1}{P_3} \right)}{\pi^2 \times D_3^4 \times M} - \frac{16 \times f_3 \times z_3 \times m_3^2 \times R \times T \times L_3}{\pi^2 \times D_3^5 \times M}$
4	$N_1 - N_4$	$P_1^2 - P_4^2 = \frac{32 \times m_4^2 \times z_4 \times R \times T \times \log_{10} \left(\frac{P_1}{P_4} \right)}{\pi^2 \times D_4^4 \times M} - \frac{16 \times f_4 \times z_4 \times m_4^2 \times R \times T \times L_4}{\pi^2 \times D_4^5 \times M}$
5	$N_5 - N_8$	$P_5^2 - P_8^2 = \frac{32 \times m_5^2 \times z_5 \times R \times T \times \log_{10} \left(\frac{P_5}{P_8} \right)}{\pi^2 \times D_5^4 \times M} - \frac{16 \times f_5 \times z_5 \times m_5^2 \times R \times T \times L_5}{\pi^2 \times D_5^5 \times M}$
6	$N_6 - N_8$	$P_6^2 - P_8^2 = \frac{32 \times m_6^2 \times z_6 \times R \times T \times \log_{10} \left(\frac{P_6}{P_8} \right)}{\pi^2 \times D_6^4 \times M} - \frac{16 \times f_6 \times z_6 \times m_6^2 \times R \times T \times L_6}{\pi^2 \times D_6^5 \times M}$
7	$N_7 - N_8$	$P_7^2 - P_8^2 = \frac{32 \times m_7^2 \times z_7 \times R \times T \times \log_{10} \left(\frac{P_7}{P_8} \right)}{\pi^2 \times D_7^4 \times M} - \frac{16 \times f_7 \times z_7 \times m_7^2 \times R \times T \times L_7}{\pi^2 \times D_7^5 \times M}$

8	$N_8 - N_9$	$P_8^2 - P_9^2 = \frac{32 \times m_8^2 \times z_8 \times R \times T \times \log_{10} \left(\frac{P_8}{P_9} \right)}{\pi^2 \times D_8^4 \times M} - \frac{16 \times f_8 \times z_8 \times m_8^2 \times R \times T \times L_8}{\pi^2 \times D_8^5 \times M}$
9	$N_9 - N_{10}$	$P_9^2 - P_{10}^2 = \frac{32 \times m_9^2 \times z_9 \times R \times T \times \log_{10} \left(\frac{P_9}{P_{10}} \right)}{\pi^2 \times D_9^4 \times M} - \frac{16 \times f_9 \times z_9 \times m_9^2 \times R \times T \times L_9}{\pi^2 \times D_9^5 \times M}$
10	$N_9 - N_{11}$	$P_9^2 - P_{11}^2 = \frac{32 \times m_{10}^2 \times z_{10} \times R \times T \times \log_{10} \left(\frac{P_9}{P_{11}} \right)}{\pi^2 \times D_{10}^4 \times M} - \frac{16 \times f_{10} \times z_{10} \times m_{10}^2 \times R \times T \times L_{10}}{\pi^2 \times D_{10}^5 \times M}$
11	$N_9 - N_{12}$	$P_9^2 - P_{12}^2 = \frac{32 \times m_{11}^2 \times z_{11} \times R \times T \times \log_{10} \left(\frac{P_9}{P_{12}} \right)}{\pi^2 \times D_{11}^4 \times M} - \frac{16 \times f_{11} \times z_{11} \times m_{11}^2 \times R \times T \times L_{11}}{\pi^2 \times D_{11}^5 \times M}$
12	$N_{13} - N_{16}$	$P_{13}^2 - P_{16}^2 = \frac{32 \times m_{12}^2 \times z_{12} \times R \times T \times \log_{10} \left(\frac{P_{13}}{P_{16}} \right)}{\pi^2 \times D_{12}^4 \times M} - \frac{16 \times f_{12} \times z_{12} \times m_{12}^2 \times R \times T \times L_{12}}{\pi^2 \times D_{12}^5 \times M}$
13	$N_{14} - N_{16}$	$P_{14}^2 - P_{16}^2 = \frac{32 \times m_{13}^2 \times z_{13} \times R \times T \times \log_{10} \left(\frac{P_{14}}{P_{16}} \right)}{\pi^2 \times D_{13}^4 \times M} - \frac{16 \times f_{13} \times z_{13} \times m_{13}^2 \times R \times T \times L_{13}}{\pi^2 \times D_{13}^5 \times M}$
14	$N_{15} - N_{16}$	$P_{15}^2 - P_{16}^2 = \frac{32 \times m_{14}^2 \times z_{14} \times R \times T \times \log_{10} \left(\frac{P_{15}}{P_{16}} \right)}{\pi^2 \times D_{14}^4 \times M} - \frac{16 \times f_{14} \times z_{14} \times m_{14}^2 \times R \times T \times L_{14}}{\pi^2 \times D_{14}^5 \times M}$
15	$N_{16} - N_{17}$	$P_{16}^2 - P_{17}^2 = \frac{32 \times m_{15}^2 \times z_{15} \times R \times T \times \log_{10} \left(\frac{P_{16}}{P_{17}} \right)}{\pi^2 \times D_{15}^4 \times M} - \frac{16 \times f_{15} \times z_{15} \times m_{15}^2 \times R \times T \times L_{15}}{\pi^2 \times D_{15}^5 \times M}$

SUPPLEMENTRY TABLE 6
ISENTROPIC HEAD ACROSS COMPRESSORS

S. No.	Compressor No.	Isentropic Head Across Compressors
1	Compressor No.1	$h_1 = \left(\frac{z_1 \times R \times T}{M} \right) \times \left(\frac{k}{k-1} \right) \times \left[\left(\frac{P_5}{P_2} \right)^{\frac{k-1}{k}} - 1 \right]$
2	Compressor No.2	$h_2 = \left(\frac{z_2 \times R \times T}{M} \right) \times \left(\frac{k}{k-1} \right) \times \left[\left(\frac{P_6}{P_3} \right)^{\frac{k-1}{k}} - 1 \right]$
3	Compressor No.3	$h_3 = \left(\frac{z_3 \times R \times T}{M} \right) \times \left(\frac{k}{k-1} \right) \times \left[\left(\frac{P_7}{P_4} \right)^{\frac{k-1}{k}} - 1 \right]$
4	Compressor No.4	$h_4 = \left(\frac{z_4 \times R \times T}{M} \right) \times \left(\frac{k}{k-1} \right) \times \left[\left(\frac{P_{13}}{P_{10}} \right)^{\frac{k-1}{k}} - 1 \right]$
5	Compressor No.5	$h_5 = \left(\frac{z_5 \times R \times T}{M} \right) \times \left(\frac{k}{k-1} \right) \times \left[\left(\frac{P_{14}}{P_{11}} \right)^{\frac{k-1}{k}} - 1 \right]$
6	Compressor No.6	$h_6 = \left(\frac{z_6 \times R \times T}{M} \right) \times \left(\frac{k}{k-1} \right) \times \left[\left(\frac{P_{15}}{P_{12}} \right)^{\frac{k-1}{k}} - 1 \right]$

SUPPLEMENTRY TABLE 7
ISENTROPIC EFFICIENCY OF COMPRESSORS

S. No.	Compressor No.	Efficiency of Compressors
1	Compressor No.1	$\eta_1 = \frac{\left(\frac{P_5}{P_2}\right)^{\frac{k-1}{k}} - 1}{\left(\frac{P_5}{P_2}\right)^{\frac{n_p-1}{n_p}} - 1}$
2	Compressor No.2	$\eta_2 = \frac{\left(\frac{P_6}{P_3}\right)^{\frac{k-1}{k}} - 1}{\left(\frac{P_6}{P_3}\right)^{\frac{n_p-1}{n_p}} - 1}$
3	Compressor No.3	$\eta_3 = \frac{\left(\frac{P_7}{P_4}\right)^{\frac{k-1}{k}} - 1}{\left(\frac{P_7}{P_4}\right)^{\frac{n_p-1}{n_p}} - 1}$
4	Compressor No.4	$\eta_4 = \frac{\left(\frac{P_{13}}{P_{10}}\right)^{\frac{k-1}{k}} - 1}{\left(\frac{P_{13}}{P_{10}}\right)^{\frac{n_p-1}{n_p}} - 1}$
5	Compressor No.5	$\eta_5 = \frac{\left(\frac{P_{14}}{P_{11}}\right)^{\frac{k-1}{k}} - 1}{\left(\frac{P_{14}}{P_{11}}\right)^{\frac{n_p-1}{n_p}} - 1}$

6	Compressor No.6	$\eta_6 = \frac{\left(\frac{P_{15}}{P_{12}}\right)^{\frac{k-1}{k}} - 1}{\left(\frac{P_{15}}{P_{12}}\right)^{\frac{n_p-1}{n_p}} - 1}$
---	-----------------	--

SUPPLEMENTRY TABLE 8
PRESSURE BOUND ON PIPE ARCS

S. No.	Arc No.	Lower Limit of Pressure in Pipe Segments
1	$N_0 - N_1$	$1 < P_1 < \frac{2 \times t_1 \times S \times E \times F \times T'}{D_1}$
2	$N_1 - N_2$	$1 < P_2 < \frac{2 \times t_2 \times S \times E \times F \times T'}{D_2}$
3	$N_1 - N_3$	$1 < P_3 < \frac{2 \times t_3 \times S \times E \times F \times T'}{D_3}$
4	$N_1 - N_4$	$1 < P_4 < \frac{2 \times t_4 \times S \times E \times F \times T'}{D_4}$
5	$N_5 - N_8$	$1 < P_5 < \frac{2 \times t_5 \times S \times E \times F \times T'}{D_5}$
6	$N_6 - N_8$	$1 < P_6 < \frac{2 \times t_6 \times S \times E \times F \times T'}{D_6}$
7	$N_7 - N_8$	$1 < P_7 < \frac{2 \times t_7 \times S \times E \times F \times T'}{D_7}$
8	$N_8 - N_9$	$1 < P_8 < \frac{2 \times t_8 \times S \times E \times F \times T'}{D_8}$
9	$N_9 - N_{10}$	$1 < P_9 < \frac{2 \times t_9 \times S \times E \times F \times T'}{D_9}$

10	$N_9 - N_{11}$	$1 < P_{10} < \frac{2 \times t_{10} \times S \times E \times F \times T'}{D_{10}}$
11	$N_9 - N_{12}$	$1 < P_{11} < \frac{2 \times t_{11} \times S \times E \times F \times T'}{D_{11}}$
12	$N_{13} - N_{16}$	$1 < P_{12} < \frac{2 \times t_{12} \times S \times E \times F \times T'}{D_{12}}$
13	$N_{14} - N_{16}$	$1 < P_{13} < \frac{2 \times t_{13} \times S \times E \times F \times T'}{D_{13}}$
14	$N_{15} - N_{16}$	$1 < P_{14} < \frac{2 \times t_{14} \times S \times E \times F \times T'}{D_{14}}$
15	$N_{16} - N_{17}$	$1 < P_{15} < \frac{2 \times t_{15} \times S \times E \times F \times T'}{D_{15}}$

SUPPLEMENTRY TABLE 9
EROSIONAL VELOCITY IN PIPE ARCS

S. No.	Arc No.	Erosional Velocity in Pipe Segments
1	$N_0 - N_1$	$v_1 \prec v_{e1}$ Where $v_{e1} = 122 \sqrt{\frac{z_1 \times R \times T}{P_{01} \times M}}$
2	$N_1 - N_2$	$v_2 \prec v_{e2}$ Where $v_{e2} = 122 \sqrt{\frac{z_2 \times R \times T}{P_{12} \times M}}$
3	$N_1 - N_3$	$v_3 \prec v_{e3}$ Where $v_{e3} = 122 \sqrt{\frac{z_3 \times R \times T}{P_{13} \times M}}$
4	$N_1 - N_4$	$v_4 \prec v_{e4}$ Where $v_{e4} = 122 \sqrt{\frac{z_4 \times R \times T}{P_{14} \times M}}$
5	$N_5 - N_8$	$v_5 \prec v_{e5}$ Where $v_{e5} = 122 \sqrt{\frac{z_5 \times R \times T}{P_{58} \times M}}$
6	$N_6 - N_8$	$v_6 \prec v_{e6}$ Where $v_{e6} = 122 \sqrt{\frac{z_6 \times R \times T}{P_{68} \times M}}$
7	$N_7 - N_8$	$v_7 \prec v_{e7}$ Where $v_{e7} = 122 \sqrt{\frac{z_7 \times R \times T}{P_{78} \times M}}$
8	$N_8 - N_9$	$v_8 \prec v_{e8}$ Where $v_{e8} = 122 \sqrt{\frac{z_8 \times R \times T}{P_{89} \times M}}$
9	$N_9 - N_{10}$	$v_9 \prec v_{e9}$ Where $v_{e9} = 122 \sqrt{\frac{z_9 \times R \times T}{P_{910} \times M}}$
10	$N_9 - N_{11}$	$v_{10} \prec v_{e10}$ Where $v_{e10} = 122 \sqrt{\frac{z_{10} \times R \times T}{P_{911} \times M}}$

11	$N_9 - N_{12}$	$v_{11} \prec v_{e_{11}}$ Where $v_{e_{11}} = 122 \sqrt{\frac{z_{11} \times R \times T}{P_{912} \times M}}$
12	$N_{13} - N_{16}$	$v_{12} \prec v_{e_{12}}$ Where $v_{e_{12}} = 122 \sqrt{\frac{z_{12} \times R \times T}{P_{1316} \times M}}$
13	$N_{14} - N_{16}$	$v_{13} \prec v_{e_{13}}$ Where $v_{e_{13}} = 122 \sqrt{\frac{z_{13} \times R \times T}{P_{1416} \times M}}$
14	$N_{15} - N_{16}$	$v_{14} \prec v_{e_{14}}$ Where $v_{e_{14}} = 122 \sqrt{\frac{z_{14} \times R \times T}{P_{1516} \times M}}$
15	$N_{16} - N_{17}$	$v_{15} \prec v_{e_{15}}$ Where $v_{e_{15}} = 122 \sqrt{\frac{z_{15} \times R \times T}{P_{1617} \times M}}$

SUPPLEMENTARY TABLE 10

VOLUMETRIC FLOW RATE AT INLET OF COMPRESSORS TO AVOID CHOKING

S. No.	Node	Equation for Volumetric Flow Rate
1	N_2	$q_{2\max} < \left(\frac{\pi}{4} \times D_2^2 \right) \times c_2 \times \left(\frac{2}{k+1} \right)^{\frac{k+1}{2 \times (k-1)}}$ $c_2 = \sqrt{\frac{k \times z_2 \times R \times T}{M}}$ <div style="text-align: right;">Where</div>
2	N_3	$q_{3\max} < \left(\frac{\pi}{4} \times D_3^2 \right) \times c_3 \times \left(\frac{2}{k+1} \right)^{\frac{k+1}{2 \times (k-1)}}$ $c_3 = \sqrt{\frac{k \times z_3 \times R \times T}{M}}$ <div style="text-align: right;">Where</div>
3	N_4	$q_{4\max} < \left(\frac{\pi}{4} \times D_4^2 \right) \times c_4 \times \left(\frac{2}{k+1} \right)^{\frac{k+1}{2 \times (k-1)}}$ $c_4 = \sqrt{\frac{k \times z_4 \times R \times T}{M}}$ <div style="text-align: right;">Where</div>
4	N_9	$q_{9\max} < \left(\frac{\pi}{4} \times D_9^2 \right) \times c_9 \times \left(\frac{2}{k+1} \right)^{\frac{k+1}{2 \times (k-1)}}$ $c_9 = \sqrt{\frac{k \times z_9 \times R \times T}{M}}$ <div style="text-align: right;">Where</div>
5	N_{10}	$q_{10\max} < \left(\frac{\pi}{4} \times D_{10}^2 \right) \times c_{10} \times \left(\frac{2}{k+1} \right)^{\frac{k+1}{2 \times (k-1)}}$ $c_{10} = \sqrt{\frac{k \times z_{10} \times R \times T}{M}}$ <div style="text-align: right;">Where</div>
		$q_{11\max} < \left(\frac{\pi}{4} \times D_{11}^2 \right) \times c_{11} \times \left(\frac{2}{k+1} \right)^{\frac{k+1}{2 \times (k-1)}}$

6	N_{11}	Where $c_{11} = \sqrt{\frac{k \times z_{11} \times R \times T}{M}}$
---	----------	---

SUPPLEMENTARY TABLE 11
AVERAGE PRESSURE IN PIPE SEGMENTS

S. No.	Equation for Average Pressure
1	$P_{25-26} = \left(\frac{2}{3}\right) \times \left[P_{25} + P_{26} - \frac{P_{25} \times P_{26}}{P_{25} + P_{26}} \right]$
2	$P_{24-25} = \left(\frac{2}{3}\right) \times \left[P_{24} + P_{25} - \frac{P_{24} \times P_{25}}{P_{24} + P_{25}} \right]$
3	$P_{22-23} = \left(\frac{2}{3}\right) \times \left[P_{22} + P_{23} - \frac{P_{22} \times P_{23}}{P_{22} + P_{23}} \right]$
4	$P_{21-22} = \left(\frac{2}{3}\right) \times \left[P_{21} + P_{22} - \frac{P_{21} \times P_{22}}{P_{21} + P_{22}} \right]$
5	$P_{38-39} = \left(\frac{2}{3}\right) \times \left[P_{38} + P_{39} - \frac{P_{38} \times P_{39}}{P_{38} + P_{39}} \right]$
6	$P_{29-30} = \left(\frac{2}{3}\right) \times \left[P_{29} + P_{30} - \frac{P_{29} \times P_{30}}{P_{29} + P_{30}} \right]$
7	$P_{36-28} = \left(\frac{2}{3}\right) \times \left[P_{36} + P_{28} - \frac{P_{36} \times P_{28}}{P_{36} + P_{28}} \right]$
8	$P_{40-37} = \left(\frac{2}{3}\right) \times \left[P_{37} + P_{40} - \frac{P_{40} \times P_{37}}{P_{40} + P_{37}} \right]$
9	$P_{41-36} = \left(\frac{2}{3}\right) \times \left[P_{41} + P_{36} - \frac{P_{41} \times P_{36}}{P_{41} + P_{36}} \right]$
10	$P_{42-41} = \left(\frac{2}{3}\right) \times \left[P_{42} + P_{41} - \frac{P_{42} \times P_{41}}{P_{42} + P_{41}} \right]$

11	$P_{02-01} = \left(\frac{2}{3}\right) \times \left[P_{02} + P_{01} - \frac{P_{02} \times P_{01}}{P_{02} + P_{01}} \right]$
12	$P_{03-02} = \left(\frac{2}{3}\right) \times \left[P_{03} + P_{02} - \frac{P_{03} \times P_{02}}{P_{03} + P_{02}} \right]$
13	$P_{05-03} = \left(\frac{2}{3}\right) \times \left[P_{05} + P_{03} - \frac{P_{05} \times P_{03}}{P_{05} + P_{03}} \right]$
14	$P_{03-04} = \left(\frac{2}{3}\right) \times \left[P_{03} + P_{04} - \frac{P_{04} \times P_{03}}{P_{04} + P_{03}} \right]$
15	$P_{09-08} = \left(\frac{2}{3}\right) \times \left[P_{09} + P_{08} - \frac{P_{09} \times P_{08}}{P_{09} + P_{08}} \right]$
16	$P_{11-10} = \left(\frac{2}{3}\right) \times \left[P_{11} + P_{10} - \frac{P_{11} \times P_{10}}{P_{11} + P_{10}} \right]$
17	$P_{13-12} = \left(\frac{2}{3}\right) \times \left[P_{13} + P_{12} - \frac{P_{12} \times P_{13}}{P_{13} + P_{12}} \right]$
18	$P_{44-45} = \left(\frac{2}{3}\right) \times \left[P_{44} + P_{45} - \frac{P_{44} \times P_{45}}{P_{44} + P_{45}} \right]$
19	$P_{43-44} = \left(\frac{2}{3}\right) \times \left[P_{43} + P_{44} - \frac{P_{44} \times P_{43}}{P_{44} + P_{43}} \right]$
20	$P_{19-43} = \left(\frac{2}{3}\right) \times \left[P_{19} + P_{43} - \frac{P_{19} \times P_{43}}{P_{19} + P_{43}} \right]$
21	$P_{17-18} = \left(\frac{2}{3}\right) \times \left[P_{17} + P_{18} - \frac{P_{17} \times P_{18}}{P_{17} + P_{18}} \right]$
22	$P_{14-17} = \left(\frac{2}{3}\right) \times \left[P_{14} + P_{17} - \frac{P_{14} \times P_{17}}{P_{14} + P_{17}} \right]$
23	$P_{16-15} = \left(\frac{2}{3}\right) \times \left[P_{16} + P_{15} - \frac{P_{16} \times P_{15}}{P_{16} + P_{15}} \right]$
24	$P_{06-07} = \left(\frac{2}{3}\right) \times \left[P_{06} + P_{07} - \frac{P_{06} \times P_{07}}{P_{06} + P_{07}} \right]$

25	$P_{25-26} = \left(\frac{2}{3}\right) \times \left[P_{25} + P_{26} - \frac{P_{25} \times P_{26}}{P_{25} + P_{26}} \right]$
26	$P_{31-27} = \left(\frac{2}{3}\right) \times \left[P_{31} + P_{27} - \frac{P_{31} \times P_{27}}{P_{31} + P_{27}} \right]$
27	$P_{32-31} = \left(\frac{2}{3}\right) \times \left[P_{32} + P_{31} - \frac{P_{32} \times P_{31}}{P_{32} + P_{31}} \right]$
28	$P_{34-33} = \left(\frac{2}{3}\right) \times \left[P_{34} + P_{33} - \frac{P_{34} \times P_{33}}{P_{34} + P_{33}} \right]$
29	$P_{35-34} = \left(\frac{2}{3}\right) \times \left[P_{35} + P_{34} - \frac{P_{35} \times P_{34}}{P_{35} + P_{34}} \right]$
30	$P_{19-20} = \left(\frac{2}{3}\right) \times \left[P_{19} + P_{20} - \frac{P_{19} \times P_{20}}{P_{19} + P_{20}} \right]$

SUPPLEMENTARY TABLE 12

COMPRESSIBILITY FACTOR IN PIPE SEGMENTS

S. No	Equation for Compressibility Factor
1	$z_1=1+\left(0.257-0.533*\frac{T_c}{T}\right)*\left(\frac{P_{25-26}}{P_c}\right)$
2	$z_2=1+\left(0.257-0.533*\frac{T_c}{T}\right)*\left(\frac{P_{24-25}}{P_c}\right)$
3	$z_3=1+\left(0.257-0.533*\frac{T_c}{T}\right)*\left(\frac{P_{22-23}}{P_c}\right)$
4	$z_4=1+\left(0.257-0.533*\frac{T_c}{T}\right)*\left(\frac{P_{21-22}}{P_c}\right)$
5	$z_5=1+\left(0.257-0.533*\frac{T_c}{T}\right)*\left(\frac{P_{38-39}}{P_c}\right)$
6	$z_6=1+\left(0.257-0.533*\frac{T_c}{T}\right)*\left(\frac{P_{29-30}}{P_c}\right)$
7	$z_7=1+\left(0.257-0.533*\frac{T_c}{T}\right)*\left(\frac{P_{36-28}}{P_c}\right)$
8	$z_8=1+\left(0.257-0.533*\frac{T_c}{T}\right)*\left(\frac{P_{40-37}}{P_c}\right)$
9	$z_9=1+\left(0.257-0.533*\frac{T_c}{T}\right)*\left(\frac{P_{41-36}}{P_c}\right)$
10	$z_{10}=1+\left(0.257-0.533*\frac{T_c}{T}\right)*\left(\frac{P_{42-41}}{P_c}\right)$
11	$z_{11}=1+\left(0.257-0.533*\frac{T_c}{T}\right)*\left(\frac{P_{02-01}}{P_c}\right)$
12	$z_{12}=1+\left(0.257-0.533*\frac{T_c}{T}\right)*\left(\frac{P_{03-02}}{P_c}\right)$

13	$z_{13}=1+\left(0.257-0.533*\frac{T_c}{T}\right)*\left(\frac{P_{05-03}}{P_c}\right)$
14	$z_{14}=1+\left(0.257-0.533*\frac{T_c}{T}\right)*\left(\frac{P_{03-04}}{P_c}\right)$
15	$z_{15}=1+\left(0.257-0.533*\frac{T_c}{T}\right)*\left(\frac{P_{09-08}}{P_c}\right)$
16	$z_{16}=1+\left(0.257-0.533*\frac{T_c}{T}\right)*\left(\frac{P_{11-10}}{P_c}\right)$
17	$z_{17}=1+\left(0.257-0.533*\frac{T_c}{T}\right)*\left(\frac{P_{13-12}}{P_c}\right)$
18	$z_{18}=1+\left(0.257-0.533*\frac{T_c}{T}\right)*\left(\frac{P_{44-45}}{P_c}\right)$
19	$z_{19}=1+\left(0.257-0.533*\frac{T_c}{T}\right)*\left(\frac{P_{43-44}}{P_c}\right)$
20	$z_{20}=1+\left(0.257-0.533*\frac{T_c}{T}\right)*\left(\frac{P_{19-43}}{P_c}\right)$
21	$z_{21}=1+\left(0.257-0.533*\frac{T_c}{T}\right)*\left(\frac{P_{17-18}}{P_c}\right)$
22	$z_{22}=1+\left(0.257-0.533*\frac{T_c}{T}\right)*\left(\frac{P_{14-17}}{P_c}\right)$
23	$z_{23}=1+\left(0.257-0.533*\frac{T_c}{T}\right)*\left(\frac{P_{16-15}}{P_c}\right)$
24	$z_{24}=1+\left(0.257-0.533*\frac{T_c}{T}\right)*\left(\frac{P_{06-07}}{P_c}\right)$
25	$z_{25}=1+\left(0.257-0.533*\frac{T_c}{T}\right)*\left(\frac{P_{25-26}}{P_c}\right)$
26	$z_{26}=1+\left(0.257-0.533*\frac{T_c}{T}\right)*\left(\frac{P_{31-27}}{P_c}\right)$

27	$z_{27} = 1 + \left(0.257 - 0.533 * \frac{T_c}{T} \right) * \left(\frac{P_{32-31}}{P_c} \right)$
28	$z_{28} = 1 + \left(0.257 - 0.533 * \frac{T_c}{T} \right) * \left(\frac{P_{34-33}}{P_c} \right)$
29	$z_{29} = 1 + \left(0.257 - 0.533 * \frac{T_c}{T} \right) * \left(\frac{P_{35-34}}{P_c} \right)$
30	$z_{30} = 1 + \left(0.257 - 0.533 * \frac{T_c}{T} \right) * \left(\frac{P_{19-20}}{P_c} \right)$

SUPPLEMENTARY TABLE 13

PRESSURE DROP EQUATION IN PIPE ARCS

S. No.	Equations for Pressure Drop Calculation
1	$P_{25}^2 - P_{26}^2 = \left(\frac{32 \times 10^{13} \times m_1^2 \times z_1 \times R \times T \times \log_{10} \left(\frac{P_{25}}{P_{26}} \right)}{\pi^2 \times D_1^4 \times M} \right) - \left(\frac{16 \times f_1 \times z_1 \times R \times T \times m_1^2 \times L_1}{\pi^2 \times D_1^5 \times M} \right)$
2	$P_{24}^2 - P_{25}^2 = \left(\frac{32 \times 10^{13} \times m_2^2 \times z_2 \times R \times T \times \log_{10} \left(\frac{P_{25}}{P_{24}} \right)}{\pi^2 \times D_2^4 \times M} \right) - \left(\frac{16 \times f_2 \times z_2 \times R \times T \times m_2^2 \times L_2}{\pi^2 \times D_2^5 \times M} \right)$
3	$P_{22}^2 - P_{23}^2 = \left(\frac{32 \times 10^{13} \times m_3^2 \times z_3 \times R \times T \times \log_{10} \left(\frac{P_{22}}{P_{23}} \right)}{\pi^2 \times D_3^4 \times M} \right) - \left(\frac{16 \times f_3 \times z_3 \times R \times T \times m_3^2 \times L_3}{\pi^2 \times D_3^5 \times M} \right)$
4	$P_{21}^2 - P_{22}^2 = \left(\frac{32 \times 10^{13} \times m_4^2 \times z_4 \times R \times T \times \log_{10} \left(\frac{P_{21}}{P_{22}} \right)}{\pi^2 \times D_4^4 \times M} \right) - \left(\frac{16 \times f_4 \times z_4 \times R \times T \times m_4^2 \times L_4}{\pi^2 \times D_4^5 \times M} \right)$
5	$P_{38}^2 - P_{39}^2 = \frac{32 \times 10^{13} \times m_5^2 \times z_5 \times R \times T \times \log_{10} \left(\frac{P_{38}}{P_{39}} \right)}{\pi^2 \times D_5^4 \times M} - \frac{16 \times f_5 \times z_5 \times R \times T \times m_5^2 \times L_5}{\pi^2 \times D_5^5 \times M}$
6	$P_{30}^2 - P_{29}^2 = \left(\frac{32 \times 10^{13} \times m_6^2 \times z_6 \times R \times T \times \log_{10} \left(\frac{P_{30}}{P_{29}} \right)}{\pi^2 \times D_6^4 \times M} \right) - \left(\frac{16 \times f_6 \times z_6 \times R \times T \times m_6^2 \times L_6}{\pi^2 \times D_6^5 \times M} \right)$
7	$P_{36}^2 - P_{28}^2 = \left(\frac{32 \times 10^{13} \times m_7^2 \times z_7 \times R \times T \times \log_{10} \left(\frac{P_{36}}{P_{28}} \right)}{\pi^2 \times D_7^4 \times M} \right) - \left(\frac{16 \times f_7 \times z_7 \times R \times T \times m_7^2 \times L_7}{\pi^2 \times D_7^5 \times M} \right)$

8	$P_{40}^2 - P_{37}^2 = \left(\frac{32 \times 10^{13} \times m_8^2 \times z_8 \times R \times T \times \log_{10} \left(\frac{P_{40}}{P_{37}} \right)}{\pi^2 \times D_8^4 \times M} \right) - \left(\frac{16 \times f_8 \times z_8 \times R \times T \times m_8^2 \times L_8}{\pi^2 \times D_8^5 \times M} \right)$
9	$P_{41}^2 - P_{36}^2 = \left(\frac{32 \times 10^{13} \times m_9^2 \times z_9 \times R \times T \times \log_{10} \left(\frac{P_{41}}{P_{36}} \right)}{\pi^2 \times D_9^4 \times M} \right) - \left(\frac{16 \times f_9 \times z_9 \times R \times T \times m_9^2 \times L_9}{\pi^2 \times D_9^5 \times M} \right)$
10	$P_{42}^2 - P_{41}^2 = \left(\frac{32 \times 10^{13} \times m_{10}^2 \times z_{10} \times R \times T \times \log_{10} \left(\frac{P_{42}}{P_{41}} \right)}{\pi^2 \times D_{10}^4 \times M} \right) - \left(\frac{16 \times f_{10} \times z_{10} \times R \times T \times m_{10}^2 \times L_{10}}{\pi^2 \times D_{10}^5 \times M} \right)$
11	$P_1^2 - P_2^2 = \left(\frac{32 \times 10^{13} \times m_{11}^2 \times z_{11} \times R \times T \times \log_{10} \left(\frac{P_2}{P_1} \right)}{\pi^2 \times D_{11}^4 \times M} \right) - \left(\frac{16 \times f_{11} \times z_{11} \times R \times T \times m_{11}^2 \times L_{11}}{\pi^2 \times D_{11}^5 \times M} \right)$
12	$P_{03}^2 - P_{02}^2 = \left(\frac{32 \times 10^{13} \times m_{12}^2 \times z_{12} \times R \times T \times \log_{10} \left(\frac{P_{03}}{P_{02}} \right)}{\pi^2 \times D_{12}^4 \times M} \right) - \left(\frac{16 \times f_{12} \times z_{12} \times R \times T \times m_{12}^2 \times L_{12}}{\pi^2 \times D_{12}^5 \times M} \right)$
13	$P_{05}^2 - P_{03}^2 = \left(\frac{32 \times 10^{13} \times m_{13}^2 \times z_{13} \times R \times T \times \log_{10} \left(\frac{P_{05}}{P_{03}} \right)}{\pi^2 \times D_{13}^4 \times M} \right) - \left(\frac{16 \times f_{13} \times z_{13} \times R \times T \times m_{13}^2 \times L_{13}}{\pi^2 \times D_{13}^5 \times M} \right)$
14	$P_{03}^2 - P_{04}^2 = \left(\frac{32 \times 10^{13} \times m_{14}^2 \times z_{14} \times R \times T \times \log_{10} \left(\frac{P_{03}}{P_{04}} \right)}{\pi^2 \times D_{14}^4 \times M} \right) - \left(\frac{16 \times f_{14} \times z_{14} \times R \times T \times m_{14}^2 \times L_{14}}{\pi^2 \times D_{14}^5 \times M} \right)$
15	$P_{09}^2 - P_{08}^2 = \left(\frac{32 \times 10^{13} \times m_{15}^2 \times z_{15} \times R \times T \times \log_{10} \left(\frac{P_{09}}{P_{08}} \right)}{\pi^2 \times D_{15}^4 \times M} \right) - \left(\frac{16 \times f_{15} \times z_{15} \times R \times T \times m_{15}^2 \times L_{15}}{\pi^2 \times D_{15}^5 \times M} \right)$

16	$P_{11}^2 - P_{10}^2 = \left(\frac{32 \times 10^{13} \times m_{16}^2 \times z_{16} \times R \times T \times \log_{10} \left(\frac{P_{11}}{P_{10}} \right)}{\pi^2 \times D_{16}^4 \times M} \right) - \left(\frac{16 \times f_{16} \times z_{16} \times R \times T \times m_{16}^2 \times L_{16}}{\pi^2 \times D_{16}^5 \times M} \right)$
17	$P_{13}^2 - P_{12}^2 = \left(\frac{32 \times 10^{13} \times m_{17}^2 \times z_{17} \times R \times T \times \log_{10} \left(\frac{P_{13}}{P_{12}} \right)}{\pi^2 \times D_{17}^4 \times M} \right) - \left(\frac{16 \times f_{17} \times z_{17} \times R \times T \times m_{17}^2 \times L_{17}}{\pi^2 \times D_{17}^5 \times M} \right)$
18	$P_{44}^2 - P_{45}^2 = \left(\frac{32 \times 10^{13} \times m_{18}^2 \times z_{18} \times R \times T \times \log_{10} \left(\frac{P_{44}}{P_{45}} \right)}{\pi^2 \times D_{18}^4 \times M} \right) - \left(\frac{16 \times f_{18} \times z_{18} \times R \times T \times m_{18}^2 \times L_{18}}{\pi^2 \times D_{18}^5 \times M} \right)$
19	$P_{43}^2 - P_{44}^2 = \left(\frac{32 \times 10^{13} \times m_{19}^2 \times z_{19} \times R \times T \times \log_{10} \left(\frac{P_{43}}{P_{44}} \right)}{\pi^2 \times D_{19}^4 \times M} \right) - \left(\frac{16 \times f_{19} \times z_{19} \times R \times T \times m_{19}^2 \times L_{19}}{\pi^2 \times D_{19}^5 \times M} \right)$
20	$P_{19}^2 - P_{43}^2 = \left(\frac{32 \times 10^{13} \times m_{20}^2 \times z_{20} \times R \times T \times \log_{10} \left(\frac{P_{19}}{P_{43}} \right)}{\pi^2 \times D_{20}^4 \times M} \right) - \left(\frac{16 \times f_{20} \times z_{20} \times R \times T \times m_{20}^2 \times L_{20}}{\pi^2 \times D_{20}^5 \times M} \right)$
21	$P_{17}^2 - P_{18}^2 = \left(\frac{32 \times 10^{13} \times m_{21}^2 \times z_{21} \times R \times T \times \log_{10} \left(\frac{P_{17}}{P_{18}} \right)}{\pi^2 \times D_{21}^4 \times M} \right) - \left(\frac{16 \times f_{21} \times z_{21} \times R \times T \times m_{21}^2 \times L_{21}}{\pi^2 \times D_{21}^5 \times M} \right)$
22	$P_{14}^2 - P_{17}^2 = \left(\frac{32 \times 10^{13} \times m_{22}^2 \times z_{22} \times R \times T \times \log_{10} \left(\frac{P_{14}}{P_{17}} \right)}{\pi^2 \times D_{22}^4 \times M} \right) - \left(\frac{16 \times f_{22} \times z_{22} \times R \times T \times m_{22}^2 \times L_{22}}{\pi^2 \times D_{22}^5 \times M} \right)$
23	$P_{16}^2 - P_{15}^2 = \left(\frac{32 \times 10^{13} \times m_{23}^2 \times z_{23} \times R \times T \times \log_{10} \left(\frac{P_{16}}{P_{15}} \right)}{\pi^2 \times D_{23}^4 \times M} \right) - \left(\frac{16 \times f_{23} \times z_{23} \times R \times T \times m_{23}^2 \times L_{23}}{\pi^2 \times D_{23}^5 \times M} \right)$

24	$P_{06}^2 - P_{07}^2 = \left(\frac{32 \times 10^{13} \times m_{24}^2 \times z_{24} \times R \times T \times \log_{10} \left(\frac{P_{06}}{P_{07}} \right)}{\pi^2 \times D_{24}^4 \times M} \right) - \left(\frac{16 \times f_{24} \times z_{24} \times R \times T \times m_{24}^2 \times L_{24}}{\pi^2 \times D_{24}^5 \times M} \right)$
25	$P_{25}^2 - P_{26}^2 = \left(\frac{32 \times 10^{13} \times m_{25}^2 \times z_{25} \times R \times T \times \log_{10} \left(\frac{P_{25}}{P_{26}} \right)}{\pi^2 \times D_{25}^4 \times M} \right) - \left(\frac{16 \times f_{25} \times z_{25} \times R \times T \times m_{25}^2 \times L_{25}}{\pi^2 \times D_{25}^5 \times M} \right)$
26	$P_{31}^2 - P_{27}^2 = \left(\frac{32 \times 10^{13} \times m_{26}^2 \times z_{26} \times R \times T \times \log_{10} \left(\frac{P_{31}}{P_{27}} \right)}{\pi^2 \times D_{26}^4 \times M} \right) - \left(\frac{16 \times f_{26} \times z_{26} \times R \times T \times m_{26}^2 \times L_{26}}{\pi^2 \times D_{26}^5 \times M} \right)$
27	$P_{32}^2 - P_{31}^2 = \left(\frac{32 \times 10^{13} \times m_{27}^2 \times z_{27} \times R \times T \times \log_{10} \left(\frac{P_{32}}{P_{31}} \right)}{\pi^2 \times D_{27}^4 \times M} \right) - \left(\frac{16 \times f_{27} \times z_{27} \times R \times T \times m_{27}^2 \times L_{27}}{\pi^2 \times D_{27}^5 \times M} \right)$
28	$P_{34}^2 - P_{33}^2 = \left(\frac{32 \times 10^{13} \times m_{28}^2 \times z_{28} \times R \times T \times \log_{10} \left(\frac{P_{34}}{P_{31}} \right)}{\pi^2 \times D_{28}^4 \times M} \right) - \left(\frac{16 \times f_{28} \times z_{28} \times R \times T \times m_{28}^2 \times L_{28}}{\pi^2 \times D_{28}^5 \times M} \right)$
29	$P_{35}^2 - P_{34}^2 = \left(\frac{32 \times 10^{13} \times m_{29}^2 \times z_{29} \times R \times T \times \log_{10} \left(\frac{P_{35}}{P_{34}} \right)}{\pi^2 \times D_{29}^4 \times M} \right) - \left(\frac{16 \times f_{29} \times z_{29} \times R \times T \times m_{29}^2 \times L_{29}}{\pi^2 \times D_{29}^5 \times M} \right)$
30	$P_{19}^2 - P_{20}^2 = \left(\frac{32 \times 10^{13} \times m_{30}^2 \times z_{30} \times R \times T \times \log_{10} \left(\frac{P_{19}}{P_{20}} \right)}{\pi^2 \times D_{30}^4 \times M} \right) - \left(\frac{16 \times f_{30} \times z_{30} \times R \times T \times m_{30}^2 \times L_{30}}{\pi^2 \times D_{30}^5 \times M} \right)$

SUPPLEMENTARY TABLE 14

ISENTROPIC HEAD ACROSS COMPRESSORS

S. No.	Compressor	Equations for Isentropic Head
1	Compressor 1	$h_1 = \left(\frac{z_2 \times R \times T}{M} \right) \times \left(\frac{k}{k-1} \right) \times \left[\left(\frac{P_{23}}{P_{24}} \right)^{\frac{k-1}{k}} - 1 \right]$
2	Compressor 2	$h_2 = \left(\frac{z_{30} \times R \times T}{M} \right) \times \left(\frac{k}{k-1} \right) \times \left[\left(\frac{P_{18}}{P_{19}} \right)^{\frac{k-1}{k}} - 1 \right]$
3	Compressor 3	$h_3 = \left(\frac{z_{16} \times R \times T}{M} \right) \times \left(\frac{k}{k-1} \right) \times \left[\left(\frac{P_{12}}{P_{11}} \right)^{\frac{k-1}{k}} - 1 \right]$
4	Compressor 4	$h_4 = \left(\frac{z_{13} \times R \times T}{M} \right) \times \left(\frac{k}{k-1} \right) \times \left[\left(\frac{P_{07}}{P_{05}} \right)^{\frac{k-1}{k}} - 1 \right]$
5	Compressor 5	$h_5 = \left(\frac{z_6 \times R \times T}{M} \right) \times \left(\frac{k}{k-1} \right) \times \left[\left(\frac{P_{27}}{P_{29}} \right)^{\frac{k-1}{k}} - 1 \right]$
6	Compressor 6	$h_6 = \left(\frac{z_{22} \times R \times T}{M} \right) \times \left(\frac{k}{k-1} \right) \times \left[\left(\frac{P_{15}}{P_{12}} \right)^{\frac{k-1}{k}} - 1 \right]$
7	Compressor 7	$h_7 = \left(\frac{z_{27} \times R \times T}{M} \right) \times \left(\frac{k}{k-1} \right) \times \left[\left(\frac{P_{33}}{P_{32}} \right)^{\frac{k-1}{k}} - 1 \right]$

SUPPLEMENTARY TABLE 15

ISENTROPIC EFFICIENCY OF COMPRESSORS

S. No.	Equations for Efficiency of Compressors
1	$\eta_1 = \frac{\left(\frac{P_{23}}{P_{24}}\right)^{\frac{k-1}{k}} - 1}{\left(\frac{P_{23}}{P_{24}}\right)^{\frac{n_p-1}{n_p}} - 1}$
2	$\eta_2 = \frac{\left(\frac{P_{18}}{P_{19}}\right)^{\frac{k-1}{k}} - 1}{\left(\frac{P_{18}}{P_{19}}\right)^{\frac{n_p-1}{n_p}} - 1}$
3	$\eta_3 = \frac{\left(\frac{P_{12}}{P_{11}}\right)^{\frac{k-1}{k}} - 1}{\left(\frac{P_{12}}{P_{11}}\right)^{\frac{n_p-1}{n_p}} - 1}$
4	$\eta_4 = \frac{\left(\frac{P_{07}}{P_{05}}\right)^{\frac{k-1}{k}} - 1}{\left(\frac{P_{07}}{P_{05}}\right)^{\frac{n_p-1}{n_p}} - 1}$
5	$\eta_5 = \frac{\left(\frac{P_{27}}{P_{29}}\right)^{\frac{k-1}{k}} - 1}{\left(\frac{P_{27}}{P_{29}}\right)^{\frac{n_p-1}{n_p}} - 1}$

6	$\eta_6 = \frac{\left(\frac{P_{15}}{P_{14}}\right)^{\frac{k-1}{k}} - 1}{\left(\frac{P_{15}}{P_{14}}\right)^{\frac{n_p-1}{n_p}} - 1}$
7	$\eta_7 = \frac{\left(\frac{P_{33}}{P_{32}}\right)^{\frac{k-1}{k}} - 1}{\left(\frac{P_{33}}{P_{32}}\right)^{\frac{n_p-1}{n_p}} - 1}$

SUPPLEMENTARY TABLE 16
FUEL CONSUMPTION IN COMPRESSORS

S. No.	Equation for Fuel Consumption in Compressors
1	$m_{f_1} = \left(\frac{(m_2 - m_{f_1}) \times h_1}{N_d \times N_m \times n_1 \times H_m} \right)$
2	$m_{f_2} = \left(\frac{(m_{30} - m_{f_2}) \times h_2}{N_d \times N_m \times n_2 \times H_m} \right)$
3	$m_{f_3} = \left(\frac{(m_{16} - m_{f_3}) \times h_3}{N_d \times N_m \times n_3 \times H_m} \right)$
4	$m_{f_4} = \left(\frac{(m_{13} - m_{f_4}) \times h_4}{N_d \times N_m \times n_4 \times H_m} \right)$
5	$m_{f_5} = \left(\frac{(m_6 - m_{f_5}) \times h_5}{N_d \times N_m \times n_5 \times H_m} \right)$
6	$m_{f_6} = \left(\frac{(m_{22} - m_{f_6}) \times h_6}{N_d \times N_m \times n_6 \times H_m} \right)$
7	$m_{f_7} = \left(\frac{(m_{27} - m_{f_7}) \times h_7}{N_d \times N_m \times n_7 \times H_m} \right)$

SUPPLEMENTARY TABLE 17

EROSIONAL VELOCITY IN PIPELINE ARCS

S. No.	Equation for Erosional Velocity
1	$v_{e_1} = 122 \sqrt{\frac{z_1 \times R \times T}{P_{25-26} \times M}}$
2	$v_{e_2} = 122 \sqrt{\frac{z_2 \times R \times T}{P_{24-25} \times M}}$
3	$v_{e_3} = 122 \sqrt{\frac{z_3 \times R \times T}{P_{22-23} \times M}}$
4	$v_{e_4} = 122 \sqrt{\frac{z_4 \times R \times T}{P_{21-22} \times M}}$
5	$v_{e_5} = 122 \sqrt{\frac{z_5 \times R \times T}{P_{38-39} \times M}}$
6	$v_{e_6} = 122 \sqrt{\frac{z_6 \times R \times T}{P_{29-30} \times M}}$
7	$v_{e_7} = 122 \sqrt{\frac{z_7 \times R \times T}{P_{36-28} \times M}}$
8	$v_{e_8} = 122 \sqrt{\frac{z_8 \times R \times T}{P_{40-37} \times M}}$
9	$v_{e_9} = 122 \sqrt{\frac{z_9 \times R \times T}{P_{41-36} \times M}}$

10	$v_{e_{10}} = 122 \sqrt{\frac{z_{10} \times R \times T}{P_{42-41} \times M}}$
11	$v_{e_{11}} = 122 \sqrt{\frac{z_{11} \times R \times T}{P_{02-01} \times M}}$
12	$v_{e_{12}} = 122 \sqrt{\frac{z_{12} \times R \times T}{P_{03-02} \times M}}$
13	$v_{e_{13}} = 122 \sqrt{\frac{z_{13} \times R \times T}{P_{05-03} \times M}}$
14	$v_{e_{14}} = 122 \sqrt{\frac{z_{14} \times R \times T}{P_{03-04} \times M}}$
15	$v_{e_{15}} = 122 \sqrt{\frac{z_{15} \times R \times T}{P_{09-08} \times M}}$
16	$v_{e_{16}} = 122 \sqrt{\frac{z_{16} \times R \times T}{P_{11-10} \times M}}$
17	$v_{e_{17}} = 122 \sqrt{\frac{z_{17} \times R \times T}{P_{13-12} \times M}}$
18	$v_{e_{18}} = 122 \sqrt{\frac{z_{18} \times R \times T}{P_{44-45} \times M}}$
19	$v_{e_{19}} = 122 \sqrt{\frac{z_{19} \times R \times T}{P_{43-44} \times M}}$
20	$v_{e_{20}} = 122 \sqrt{\frac{z_{20} \times R \times T}{P_{19-43} \times M}}$
21	$v_{e_{21}} = 122 \sqrt{\frac{z_{21} \times R \times T}{P_{17-18} \times M}}$
22	$v_{e_{22}} = 122 \sqrt{\frac{z_{22} \times R \times T}{P_{14-17} \times M}}$
23	$v_{e_{23}} = 122 \sqrt{\frac{z_{23} \times R \times T}{P_{16-15} \times M}}$

24	$v_{e_{24}} = 122 \sqrt{\frac{z_{24} \times R \times T}{P_{06-07} \times M}}$
25	$v_{e_{25}} = 122 \sqrt{\frac{z_{25} \times R \times T}{P_{25-26} \times M}}$
26	$v_{e_{26}} = 122 \sqrt{\frac{z_{26} \times R \times T}{P_{31-27} \times M}}$
27	$v_{e_{27}} = 122 \sqrt{\frac{z_{27} \times R \times T}{P_{32-31} \times M}}$
28	$v_{e_{28}} = 122 \sqrt{\frac{z_{28} \times R \times T}{P_{34-33} \times M}}$
29	$v_{e_{29}} = 122 \sqrt{\frac{z_{29} \times R \times T}{P_{35-34} \times M}}$
30	$v_{e_{30}} = 122 \sqrt{\frac{z_{30} \times R \times T}{P_{19-20} \times M}}$