

| | |
|----------------------|--|
| Name: |  UPES UNIVERSITY WITH A PURPOSE |
| Enrolment No: | |

UNIVERSITY OF PETROLEUM AND ENERGY STUDIES
End Semester Examination, May 2019

| | |
|---|------------------------|
| Course: Design of Steel Structure | Semester: VI |
| Program: B.Tech. Civil Engineering | Time 03 hrs. |
| Course Code: CEEG 3007 | Max. Marks: 100 |
| Total Pages: 3 | |

Instructions: Answer all questions of Section A, B & C
 (Assume all the necessary data if necessary) (Internal Choice is there in Q 6-Section B and Q 11-Section C)
Note: IS 800:2007 and IS 808:1989 should be Allowed/Provided.....

SECTION A

| S. No. | | Marks | CO | | | | | | |
|---|---|---|-------------|--------------------------------------|-------------|--|---------------|---|-----|
| Q 1 | i. If the same no. of bolts has been used in the joints, then which of the following patterns will yield highest efficiency? a. Chain b. Staggered c. Diamond d. Staggered diamond ii. Slip critical connection are designed on the basis of a. Friction of bolts b. Friction between plates c. Compression d. Shear iii. If the diameter of a bolt is 20mm then the maximum number of bolt(s) that can be accommodated in one row in 140mm wide flat is (are) a. 2 b. 3 c. 4 d. 1 iv. When the load line coincides with the c.g. of the bolt group, then the bolts are subjected to a. Only shear b. Only tension c. Only bending d. Both shear and tension | 4 | CO1 | | | | | | |
| Q 2 | Match the lists given in two tables <table border="1" style="width: 100%; border-collapse: collapse;"> <tr> <td style="width: 50%;">A-Structural members subjected to direct tension or compression</td> <td style="width: 50%;">1-Slot Weld</td> </tr> <tr> <td>B-Joining two surfaces approximately</td> <td>2-Plug Weld</td> </tr> <tr> <td></td> <td>3-Fillet Weld</td> </tr> </table> | A-Structural members subjected to direct tension or compression | 1-Slot Weld | B-Joining two surfaces approximately | 2-Plug Weld | | 3-Fillet Weld | 4 | CO1 |
| A-Structural members subjected to direct tension or compression | 1-Slot Weld | | | | | | | | |
| B-Joining two surfaces approximately | 2-Plug Weld | | | | | | | | |
| | 3-Fillet Weld | | | | | | | | |

| | | | | |
|-----|---|--------------|-------|------------|
| | at right angles to each other C-A hole is made in one of the components and welding is done around the periphery of the hole D-Welding rod inside of a pipe | 4- Butt Weld | | |
| Q 3 | i. Under what circumstances will block shear failure dominate? ii. Why are unequal angles with long legs connected more efficient for tension members? | | 2+2=4 | CO2 |
| Q 4 | i. Compression members are more critical than tension members. Comment! ii. Why four different buckling curves are prescribed to evaluate column strength? | | 2+2=4 | CO2 |
| Q 5 | i. Differentiate between buckling and bending of a beam. ii. What is the importance of purlin in a steel truss? | | 2+2=4 | CO3 CO4 |

SECTION B

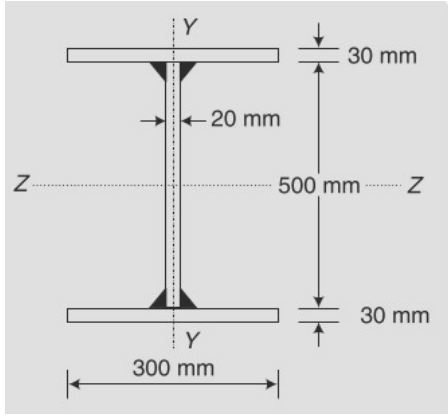
| | | | |
|-----|--|----|-----|
| Q 6 | <p>For a column section built up of shape shown in figure, determine the axial load capacity in compression for the data $L = 6m$, End conditions: Both end restrained in direction and position, $\gamma_{mf} = 1.5$</p>  <p style="text-align: center;">OR</p> <p>Determine the effective length factor for the column C2C3 of an unbraced frame shown in figure with $C = 0.6$ Columns $1/L = 1.2$ g units Beams B_1, $1/L = 1.4$ g units B_2, $1/L = g$ units</p> | 10 | CO2 |
|-----|--|----|-----|

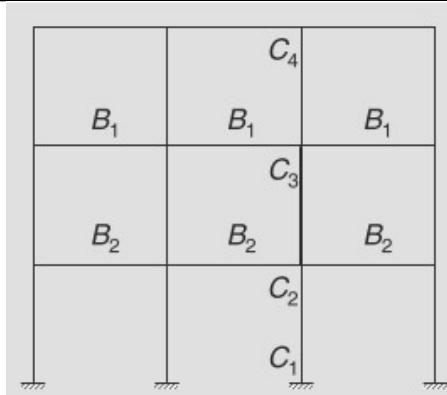

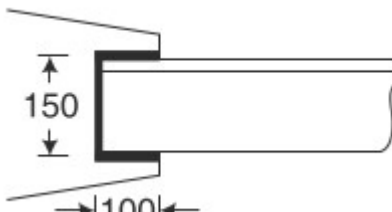
| | | | |
|-----|---|----|-----|
| Q 7 | <p>Compute the tensile strength of an angle section ISA 150 x 75 x 10 connected with the gusset plate as shown.</p>  | 10 | CO2 |
| Q 8 | <p>An ISLC 300 @ 324.7 N/m is to carry a factored tensile force of 900 kN. The channel section is to be welded at the site to a gusset plate 10 mm thick. Design the fillet weld if the overlap is limited to 350mm.</p> | 10 | CO1 |
| Q 9 | <p>Two plates each of 200 x 8mm are to be joined using 20mm diameter 4.6 grade bolts to form a lap joint. The joint is supposed to transfer a factored load of 280 kN. Design the joint and suitable pitch for the bolts.</p> | 10 | CO1 |

SECTION-C

| | | | |
|------|---|----|-----|
| Q 10 | <p>Design an I-section purlin, for an industrial building situated in Bidholi, to support a GI roof for the following data: Spacing of truss c/c= 5m Span of the truss = 12m Slope of truss = 30 degrees Spacing of purlins c/c = 1.5m Weight of GI sheets = 120 N/mm² Wind load normal to the roof = 1500 N/m</p> | 20 | CO4 |
| Q 11 | <p>Design a lintel over an opening of 3m. the lintel is made a wall 300mm thick. The lintel has to support a uniform load of 50 kN in addition to masonry. The weight of the masonry may be assumed to 18 kN/m³ and the height of brickwork above the lintel is 3.5m.</p> <p style="text-align: center;">OR</p> <p>Design a steel beam section whose compression flange is laterally supported throughout for supporting an auditorium for the following data: Clear span = 6m End bearings = 120m c/c spacing of beams = 3.5m</p> | 20 | CO3 |

| | | | |
|--|---|--|--|
| | Imposed load on beam = 8 kN/m ² Dead load including Self weight = 3.5 kN/m ² | | |
|--|---|--|--|

Name:
Enrolment No:



UNIVERSITY OF PETROLEUM AND ENERGY STUDIES
End Semester Examination, May 2019

Course: Design of Steel Structure
Program: B.Tech. Civil Engineering
Course Code: CEEG 3007
Total Pages: 3

Semester: VI
Time 03 hrs.
Max. Marks: 100

Instructions: Answer all questions of Section A, B & C
(Assume all the necessary data if necessary) (Internal Choice is there in Q 6-SectionB and Q 11-Section C)

.....Note: IS 800:2007 and IS 808:1989 should be Allowed/Provided.....

SECTION A

| S. No. | | Marks | CO |
|--------|---|-------|-----|
| Q 1 | Mention the advantages and disadvantages of steel structures? | 4 | CO1 |
| Q 2 | Name the different types of connections? | 4 | CO1 |
| Q 3 | What are the factors that will govern the structural design? | 4 | CO1 |
| Q 4 | What are the load combinations for the design purposes? | 4 | CO1 |
| Q 5 | How the rolled steel beams are classified? | 4 | CO3 |

SECTION B

Q 6 Determine the strength and efficiency of the lap joint shown in figure. Bolt diameter is 16mm and grade of bolt is 4.6. The two plates to be joined are 10mm and 12 mm thick.

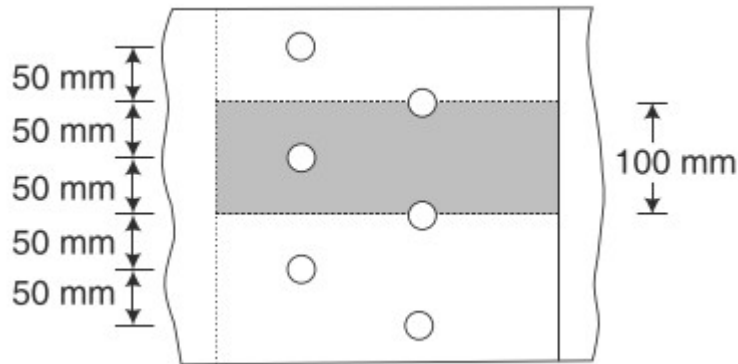

OR

Two flats each 210mm x 8mm are to be jointed using 16 mm diameter , 4.6 grade bolts to form a lap joint. The joint is supposed to transfer a factored load of 250 kN. Design the joint and determine the suitable pitch.

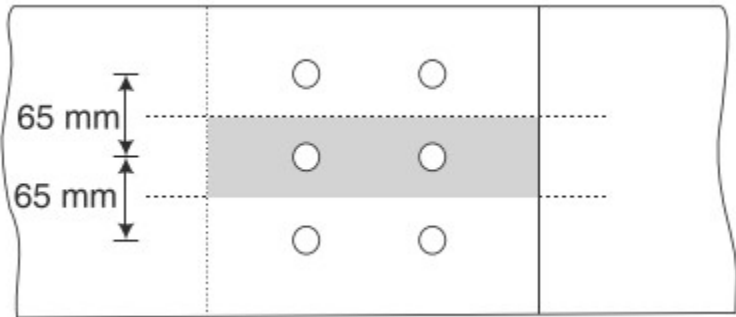
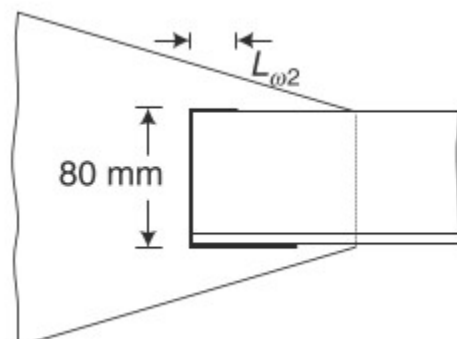
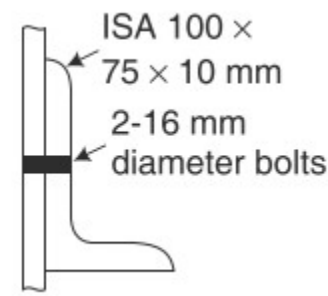
| | | | |
|-------------------------|--|-----------|------------|
| |  | | |
| <p>Q 7</p> | <p>Design the fillet weld for the angle section iSA 80 x 50 x 10 mm, if the weld is to be done on its three sides as shown in figure.</p>  | <p>10</p> | <p>CO1</p> |
| <p>Q 8</p> | <p>An ISA 100 x 75 x 10mm is connected with a gusset plate 12 mm thick with 2-16mm diameter bolts of grade 4.6 as shown in figure. Determine total net area and effective area of the section.</p>  | <p>10</p> | <p>CO2</p> |
| <p>Q 9</p> | <p>A strut of 3.4m length in a truss is connected at each end with welding to the gusset plate. The strut is of a section ISA 100 x 100 x 10 mm. Determine its effective slenderness ratio.</p> | <p>10</p> | <p>CO2</p> |
| <p>SECTION-C</p> | | | |
| <p>Q 10</p> | <p>Design an Channel-section purlin, for an industrial building situated in Bidholi, to support a GI roof for the following data: Spacing of truss c/c= 5m Span of the truss = 12m Slope of truss = 30 degrees Spacing of purlins c/c = 1.5m</p> | <p>20</p> | <p>CO4</p> |

| | | | |
|------|---|-----------|------------|
| | Weight of GI sheets = 130 N/mm ² Wind load normal to the roof = 1800 N/m | | |
| Q 11 | Design a laterally unsupported beam of span 3.5m. with maximum bending moment 550 kNm and maximum shear force 200 kN. OR Design a steel beam section whose compression flange is laterally supported throughout for supporting a large hall for the following data: Clear span = 6.5 m End bearings = 130m c/c spacing of beams = 3 m Imposed load on beam = 10 kN/m ² Dead load including Self weight = 4 kN/m ² | 20 | CO3 |