

Name:

Enrolment No:



UNIVERSITY OF PETROLEUM AND ENERGY STUDIES
End Semester Examination, May 2019

Course: Robotics based Industrial Automation
Program: M.Tech Automation and Robotics
Course Code: ECEG 7005

Semester: II
Time 03 hrs.
Max. Marks: 100

Instructions:

Assume data as per requirement.

SECTION A

S. No.		Marks	CO
Q 1	Compare the different features of hydraulic system with those of pneumatic systems.	5	CO3
Q 2	Explain the application of Pascal's law in pressure and force multiplication with relevant mathematical equations.	5	CO2
Q 3	Explain the operation of shuttle valve	5	CO1
Q 4	With the help of suitable examples illustrate programmable automation and flexible automation	5	CO4

SECTION B

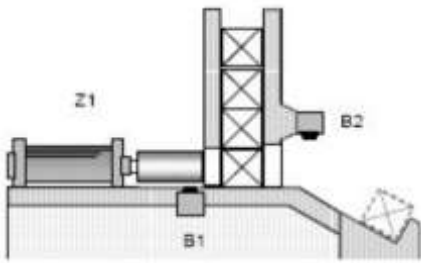
Q 5	<p>Design the a pneumatic circuit and electrical diagram to implement the following task.</p> <p>Task : "Conveying parts from a drop magazine" . After actuating the start button (S0), the piston of a double-acting cylinder pushes parts from a drop magazine on to a conveyer belt. When the piston has pushed the part out of the drop magazine, it automatically retracts. Additionally: a new start may only be possible if the piston of the cylinder is actually in its back end position. Additionally: mechanically operated signallers cannot be used for scanning cylinder plungers and parts. The signallers must operate "without contact". The working speed of the cylinder should be infinitely adjustable in both directions.</p> 	10	CO5
Q 6	Design a pneumatic circuit and electrical diagram to implement "Flap shutter for loose material" . In this task, the piston rod of a double-acting cylinder, which is mounted with the	10	CO5

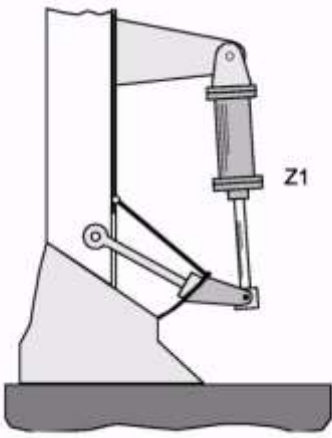
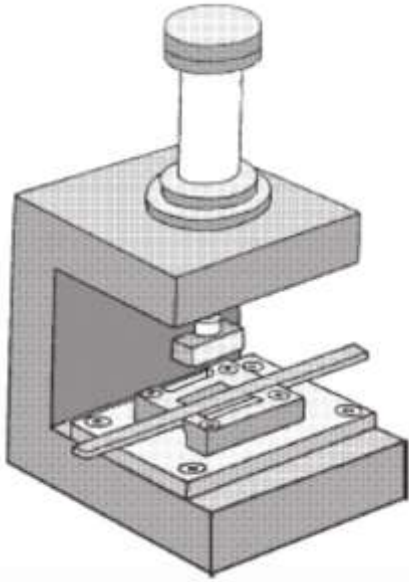
	<p>piston rod facing downwards, opens a flap shutter for loose material when a push button is pressed. After opening it to a full extent, the cylinder automatically shuts the flap shutter again. The initial setting of the cylinder rod is 'extended'.</p> <p>The extension speed should be infinitely adjustable. Cylinder switches are available for use.</p> 		
<p>Q 7</p>	<p>A double acting hydraulic cylinder is used to emboss slide rules. The cylinder extends only when two push buttons are pressed simultaneously within one second to ensure complete operator safety(both hands must be out of danger area when starting). The cylinder must retract immediately if any one push button is released. The next cycle should be only possible after both push buttons are released. Implement the circuit with a hydraulic circuit and electric diagram</p> 	<p>10</p>	<p>CO4</p>
<p>Q 8</p>	<p>To perform the following task, design a pneumatic circuit and electrical diagram Upholstered furniture are to be tested on their life span. After actuating control switch S3 (Continuous cycle), the piston rod of a double acting cylinder Z1 extends and after reaching the front end</p>	<p>10</p>	<p>CO2</p>

position retracts again. This procedure repeats itself as long as switch S3 remains” ON”
 Additional requirement: after briefly actuating push button S0, the cylinder should extend and retract once (single cycle). An electrically controlled 5/2 directional control impulse valve is used as an actuator. Cylinder switches are available as limit switches.

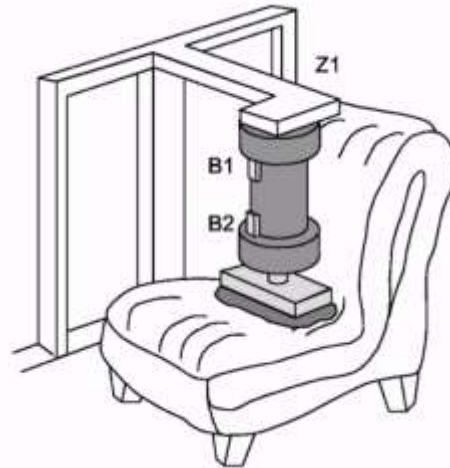

SECTION-C

Q 9 Design a pneumatic circuit and electrical diagram to implement a fire protection door. A door functioning as a fire protection door between shop A and B is opened and closed by a double acting cylinder. There is a push button to open the door located in each shop (S1 and S2). After opening, the fire protection door should remain open approx. 14 second s and then automatically shut. Additional requirements: opening the door is only possible when the door is completely shut. An acoustic signal goes on when the door is open (even if it just open a crack). A visual display in both shops indicates when the door is open or just being opened. The extension speed should be infinitely adjustable. An electrically controlled, spring return 5/2 directional control valve (monostable) is to be used as an actuator.

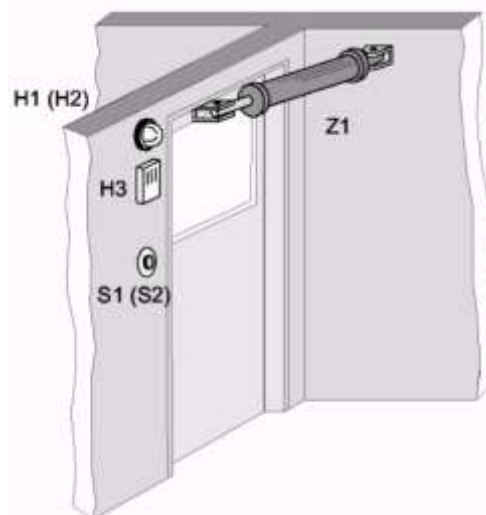

20

CO5

Q 10

Task, bending device for sheet metal parts. A stamped metal part is placed in a device: two fishplates on 2 different sides are to be bent at a right angle. At first the cylinder clamps the part, and then a second cylinder extends and bends the first fishplate. A third cylinder follows and bends the next side. The bending process for both parts may not occur simultaneously, but rather one after the other. The workpiece is manually taken out of the device when the bending. Electrically controlled 5/2 directional control impulse valves (bi-stable) are used as actuators. Signallers are electrical cylinder switches (magnetic field sensors).

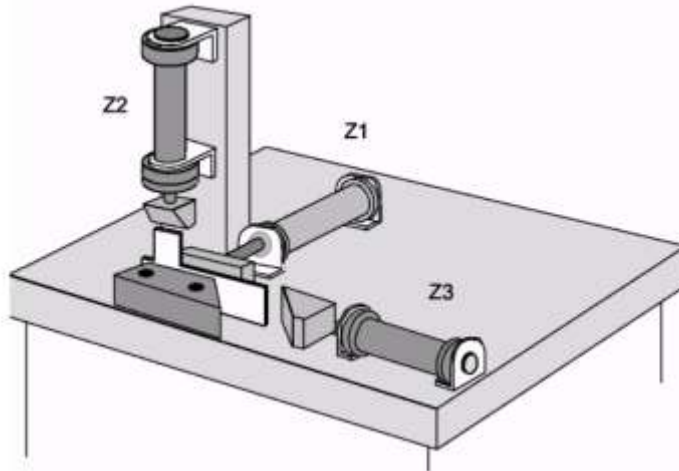

20

CO4

Name:

Enrolment No:



UNIVERSITY OF PETROLEUM AND ENERGY STUDIES
End Semester Examination, May 2019

Course: Robotics based Industrial Automation
Program: M.Tech Automation and Robotics
Course Code: ECEG 7005

Semester: II
Time 03 hrs.
Max. Marks: 100

Instructions:

Assume data as per requirement.

SECTION A

S. No.		Marks	CO
Q 1	Compare the different features of hydraulic system with those of pneumatic systems.	5	CO3
Q 2	Explain the types of timer used in hydraulic circuit.	5	CO2
Q 3	With the help of suitable examples illustrate programmable automation	5	CO1
Q 4	Explain the concept of low cost automation with a neat sketch.	5	CO4

SECTION B

Q 5 An opening for ventilation is actuated with a cylinder. Push button S1 opens the ventilation opening and it can be closed again with push button S2. As soon as any button is released, the opening (cylinder piston) remains in its current position. By briefly touching any one of the two push buttons, the opening can be brought to any middle position and fixed there. Even if the compressed air supply should fail or there should be a power failure, the opening will remain in its position. The extension and retraction speeds should be infinitely adjustable. Design a pneumatic circuit and electrical diagram to implement the task. A 5/3 directional control valve in closed mid-position is used as an actuator.

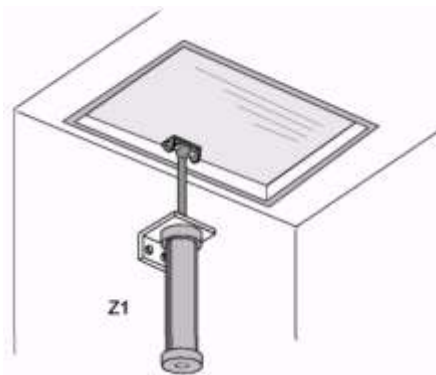

10

CO5

Q 6	Design a pneumatic circuit and electrical diagram to implement dip varnishing apparatus A cylinder lowers a basket with a work piece into an immersion bath. The basket with the work piece remains in the immersion bath for 5 seconds and is then automatically raised. The time span that the work piece is in the immersion bath can be set between 0.5 and 15 seconds. The extension speed can be infinitely adjusted. An electrically controlled 5/2 directional control impulse valve is used as an actuator. Limit switches are available for use.	10	CO5
Q 7	Design a pneumatic circuit and an electrical circuit that demonstrate logical XOR gate. Realize the circuit using two push buttons S1 and S2. The actuation of the double acting cylinder Z1 should verify the truth table of the XOR gate. Use 5X2 electrically controlled spring return impulse valve as actuators.	10	CO4
Q 8	Design circuits to explain the following : 1. Dominant ON circuit 2. 3 Safety circuit (Dominant OFF)	10	CO2
SECTION-C			
Q 9	<p>A pre-cut piece of sheet metal is to be bent into a hook. The workpiece is placed into the device, a cylinder clamps the workpiece. Another cylinder bends the sheet metal 90 degrees with the aid of a bending die. When the first bending process is completed, the second bending process begins. Another cylinder finishes bending the workpiece into a hook. The workpiece is released and removed manually. The extension speed of cylinders 2 and 3 should be infinitely adjustable. Electrically controlled, spring return 5/2 directional control impulse valves are used as actuators. The signallers are electrical cylinder switches (magnetic field sensors)</p> <div data-bbox="365 1243 1133 1549" style="text-align: center;"> </div>	20	CO5
Q 10	Plastic parts are taken from a magazine and clamped. Then the plastic parts are stamped and removed manually. Electrically controlled spring return 5/2 directional control valves are used as actuators. The signallers are electric cylinder switches (magnetic field sensors). The extension speed should be infinitely adjustable. Design a pneumatic circuit and electrical diagram to implement the task.	20	CO4

